

Service Manual



AWG610 **Arbitrary Waveform Generator**

071-0556-02

Warning

The servicing instructions are for use by qualified personnel only. To avoid personal injury, do not perform any servicing unless you are qualified to do so. Refer to the Safety Summary prior to performing service.



Copyright © Sony/Tektronix Corporation. All rights reserved.

Copyright © Tektronix, Inc. All rights reserved.

Tektronix products are covered by U.S. and foreign patents, issued and pending. Information in this publication supercedes that in all previously published material. Specifications and price change privileges reserved.

Printed in Japan.

Sony/Tektronix Corporation, P.O.Box 5209, Tokyo Int'l, Tokyo 100-3199 Japan

Tektronix, Inc., P.O. Box 1000, Wilsonville, OR 97070-1000

TEKTRONIX and TEK are registered trademarks of Tektronix, Inc.

WARRANTY

Tektronix warrants that the products that it manufactures and sells will be free from defects in materials and workmanship for a period of one (1) year from the date of shipment. If a product proves defective during this warranty period, Tektronix, at its option, either will repair the defective product without charge for parts and labor, or will provide a replacement in exchange for the defective product.

In order to obtain service under this warranty, Customer must notify Tektronix of the defect before the expiration of the warranty period and make suitable arrangements for the performance of service. Customer shall be responsible for packaging and shipping the defective product to the service center designated by Tektronix, with shipping charges prepaid. Tektronix shall pay for the return of the product to Customer if the shipment is to a location within the country in which the Tektronix service center is located. Customer shall be responsible for paying all shipping charges, duties, taxes, and any other charges for products returned to any other locations.

This warranty shall not apply to any defect, failure or damage caused by improper use or improper or inadequate maintenance and care. Tektronix shall not be obligated to furnish service under this warranty a) to repair damage resulting from attempts by personnel other than Tektronix representatives to install, repair or service the product; b) to repair damage resulting from improper use or connection to incompatible equipment; c) to repair any damage or malfunction caused by the use of non-Tektronix supplies; or d) to service a product that has been modified or integrated with other products when the effect of such modification or integration increases the time or difficulty of servicing the product.

THIS WARRANTY IS GIVEN BY TEKTRONIX IN LIEU OF ANY OTHER WARRANTIES, EXPRESS OR IMPLIED. TEKTRONIX AND ITS VENDORS DISCLAIM ANY IMPLIED WARRANTIES OF MERCHANTABILITY OR FITNESS FOR A PARTICULAR PURPOSE. TEKTRONIX' RESPONSIBILITY TO REPAIR OR REPLACE DEFECTIVE PRODUCTS IS THE SOLE AND EXCLUSIVE REMEDY PROVIDED TO THE CUSTOMER FOR BREACH OF THIS WARRANTY. TEKTRONIX AND ITS VENDORS WILL NOT BE LIABLE FOR ANY INDIRECT, SPECIAL, INCIDENTAL, OR CONSEQUENTIAL DAMAGES IRRESPECTIVE OF WHETHER TEKTRONIX OR THE VENDOR HAS ADVANCE NOTICE OF THE POSSIBILITY OF SUCH DAMAGES.

Table of Contents

List of Figures	iii
List of Tables	vi
General Safety Summary	ix
Service Safety Summary	xi
Preface	xiii
Contacting Tektronix	xv
Introduction	xvii

Specifications

Product Overview	1-1
Product Description	1-1
Specifications	1-5
Electrical Specification	1-6
Certification and Compliances	1-16

Operating Information

Preparation for Use	2-1
Supplying Operating Power	2-1
Operating Environment	2-3
Applying and Interrupting Power	2-4
Repackaging Instructions	2-5
Basic Operations	2-7
Menu System	2-7
Numeric Input	2-12
Text Input	2-14
Shortcut Controls	2-15
File Management	2-17
Signal Edit Process	2-23

Theory of Operation

Performance Verification

Conventions	4-1
Self Tests	4-3
Performance Tests	4-7
AWG610 Test Record	4-13
Operating Mode Tests	4-17
Amplitude and Offset Accuracy Tests (Normal Out)	4-24
Amplitude, Offset Accuracy and Rise Time Tests (Direct DA Out)	4-29
Pulse Response Tests	4-34
Sine Wave Tests	4-36
Internal Trigger Tests	4-38
Trigger Input Tests	4-40

Event Input and Enhanced Mode Tests	4-43
1/4 Clock Frequency and 10 MHz Reference Input Tests	4-50
1/4 Clock Output Level Tests	4-52
10 MHz Reference Output Level Tests	4-54
Marker Output Tests	4-56
Marker Delay Tests	4-59

Adjustment Procedures

Overview	5-1
Before Adjustments	5-3
Providing Access	5-3
Cooling	5-4
Performance Check/Adjustment Files	5-6
Adjustment Instructions	5-7

Maintenance

Related Maintenance Procedures	6-1
Preparation	6-2
Inspection and Cleaning	6-4
Removal and Installation Procedures	6-9
Preparation — Preparation for Use	6-9
Access Procedure	6-15
Procedures for External Modules	6-16
Procedures for Outer-Chassis Modules	6-29
Procedures for Inner-Chassis Modules	6-43
Troubleshooting	6-53
Diagnostics	6-53
Messages and Codes	6-63

Options and Accessories

Options	7-1
Standard Accessories	7-3
Optional Accessories	7-3

Replaceable Electrical Parts

Diagrams

Replaceable Mechanical Parts

Parts Ordering Information	10-1
Using the Replaceable Parts List	10-2

List of Figures

Figure 1-1: Dimensions	1-15
Figure 2-1: Menu buttons, bezel menu buttons, and the CLEAR MENU button	2-8
Figure 2-2: Bottom and side menus	2-9
Figure 2-3: Pop-up menu example	2-10
Figure 2-4: Dialog box example	2-11
Figure 2-5: Knob icon displayed in status display area	2-12
Figure 2-6: Keypad buttons	2-13
Figure 2-7: Three type of Input text dialog boxes	2-14
Figure 2-8: Shortcut controls	2-15
Figure 2-9: Files and directories with read only attribute	2-20
Figure 2-10: Input Filename dialog box	2-21
Figure 3-1: AWG610 interconnect diagram	3-2
Figure 3-2: AWG610 block diagram	3-4
Figure 3-3: Relationship between memory address control and waveform memory	3-5
Figure 4-1: Diagnostic menu	4-4
Figure 4-2: Calibration result message box	4-5
Figure 4-3: EVENT IN connector pins and signals and ground closure connector	4-9
Figure 4-4: Loading file; selecting storage drive	4-10
Figure 4-5: Cont mode initial test hookup	4-17
Figure 4-6: Triggered mode initial test hookup	4-19
Figure 4-7: Relationship between trigger signal and waveform output	4-21
Figure 4-8: Relationship between gate signal and waveform output	4-23
Figure 4-9: Amplitude accuracy initial test hookup	4-25
Figure 4-10: Direct DA output amplitude accuracy initial test hookup	4-29
Figure 4-11: Direct DA output pulse rise time initial test hookup	4-32
Figure 4-12: Pulse response initial test hookup	4-34
Figure 4-13: Sine wave initial test hookup	4-36
Figure 4-14: Internal trigger initial test hookup	4-38

Figure 4-15: Trigger input initial test hookup	4-40
Figure 4-16: Event input and enhanced mode initial test hookup	4-43
Figure 4-17: Waveform while all ground disclosure switches are open	4-45
Figure 4-18: Waveform output when the SW1 is closed	4-45
Figure 4-19: Waveform output when SW2 is closed	4-46
Figure 4-20: Waveform output when the SW3 is closed	4-47
Figure 4-21: Waveform output when SW4 is closed	4-47
Figure 4-22: Initial waveform output	4-48
Figure 4-23: DC waveform output when the SW5 is closed	4-49
Figure 4-24: 10 MHz reference initial test hookup	4-50
Figure 4-25: Clock output initial test hookup	4-52
Figure 4-26: Clock output initial test hookup	4-54
Figure 4-27: Marker output initial test hookup	4-56
Figure 4-28: Digital data output initial test hookup	4-59
Figure 5-1: Cooling the waveform generator during adjustment procedures	5-4
Figure 5-2: Accessing the service switch	5-5
Figure 5-3: Hookup for the reference clock frequency adjustment	5-7
Figure 5-4: Adjustment location for clock frequency	5-9
Figure 5-5: Hookup for the Marker level adjustment	5-10
Figure 6-1: Instrument orientation	6-11
Figure 6-2: External modules	6-12
Figure 6-3: Outer-chassis modules	6-13
Figure 6-4: Inner-chassis modules	6-14
Figure 6-5: Knob removal	6-17
Figure 6-6: Line fuse and line cord removal	6-18
Figure 6-7: Cabinet removal	6-21
Figure 6-8: Trim ring, menu buttons, and output panel removal	6-22
Figure 6-9: A20 Front-Panel assembly removal	6-24
Figure 6-10: Disassembly of Front-Panel assembly	6-25
Figure 6-11: Cabinet modules removal	6-28
Figure 6-12: Fan removal	6-30
Figure 6-13: Floppy disk removal	6-31
Figure 6-14: Power supply module removal	6-32

Figure 6-15: A11 Connector board removal	6-34
Figure 6-16: A60 Memory Board removal	6-35
Figure 6-17: A75 Noise Generator Board and A70 Output Board removal	6-37
Figure 6-18: A40 Clock Board removal	6-38
Figure 6-19: A50 AWG board removal	6-40
Figure 6-20: Rear Chassis removal	6-42
Figure 6-21: CPU unit removal	6-44
Figure 6-22: CPU, HDD/Flash disk, LAN, and GPIB boards removal	6-45
Figure 6-23: Hard disk and flash disk removal	6-46
Figure 6-24: Display assembly removal	6-49
Figure 6-25: Display Driver Board removal	6-50
Figure 6-26: Front subpanel removal	6-52
Figure 6-27: Primary troubleshooting procedure	6-54
Figure 6-28: Troubleshooting procedure 1 — Power Supply module	6-55
Figure 6-29: Power Supply connectors	6-56
Figure 6-30: Troubleshooting procedure 2 — CPU or Front Panel module	6-57
Figure 6-31: A20 Front Panel board	6-58
Figure 6-32: Troubleshooting procedure 3 — Monitor module ...	6-59
Figure 6-33: A11 Connector board	6-60
Figure 6-34: Location of the VGA connector	6-60
Figure 6-35: Horizontal and vertical sync signals	6-61
Figure 6-36: A video signal with white and black levels	6-61
Figure 6-37: Troubleshooting procedure 4 — Module isolation ...	6-62
Figure 9-1: Block diagram	9-3
Figure 9-2: Interconnections	9-4
Figure 10-1: Cabinet	10-5
Figure 10-2: Front panel	10-7
Figure 10-3: Outer chassis modules	10-9
Figure 10-4: Circuit boards	10-11
Figure 10-5: CPU unit	10-13
Figure 10-6: Chassis	10-15
Figure 10-7: Floppy disk and Fan	10-17
Figure 10-8: Display	10-19
Figure 10-9: Rack mount	10-21

List of Tables

Table 1-1: AWG610 waveform editors	1-2
Table 1-2: Operation modes	1-6
Table 1-3: Arbitrary waveforms	1-6
Table 1-4: Clock generator	1-6
Table 1-5: Internal trigger generator	1-7
Table 1-6: Main output	1-7
Table 1-7: Filter	1-9
Table 1-8: Auxiliary outputs	1-10
Table 1-9: Period Jitter accuracy	1-11
Table 1-10: Cycle to Cycle Jitter accuracy	1-11
Table 1-11: Auxiliary inputs	1-11
Table 1-12: Display and timer	1-12
Table 1-13: AC line power	1-13
Table 1-14: Timer	1-13
Table 1-15: Interface connectors	1-13
Table 1-16: Installation requirement	1-13
Table 1-17: Environmental	1-14
Table 1-18: Mechanical	1-15
Table 1-19: Certifications and compliances	1-16
Table 2-1: Power-cord conductor identification	2-2
Table 2-2: Power cord identification	2-2
Table 2-3: Side menu elements	2-10
Table 2-4: Text input button functions	2-15
Table 2-5: Shortcut control descriptions	2-16
Table 2-6: AWG610 Waveform Generator file types	2-17
Table 2-7: Drive and directory menus	2-18
Table 2-8: Waveform record length adjustment messages	2-22
Table 2-9: Editors	2-23
Table 3-1: Run modes	3-3
Table 4-1: Performance test items	4-7
Table 4-2: Test equipments	4-8
Table 4-3: Waveforms and sequences in performance check disk	4-11

Table 5-1: Adjustments required	5-1
Table 5-2: Adjustments	5-2
Table 5-3: Test equipment	5-3
Table 5-4: File list for Performance Check/Adjustment disk	5-6
Table 6-1: Relative susceptibility to static-discharge damage	6-3
Table 6-2: External Inspection Check List	6-5
Table 6-3: Internal inspection check list	6-6
Table 6-4: Tools required for module removal	6-10
Table 6-5: Device errors	6-63
Table 7-1: Power cord options	7-1
Table 7-2: Standard accessories	7-3
Table 7-3: Optional accessories	7-3

General Safety Summary

Review the following safety precautions to avoid injury and prevent damage to this product or any products connected to it. To avoid potential hazards, use this product only as specified.

Only qualified personnel should perform service procedures.

To Avoid Fire or Personal Injury

Use Proper Power Cord. Use only the power cord specified for this product and certified for the country of use.

Connect and Disconnect Properly. Do not connect or disconnect probes or test leads while they are connected to a voltage source.

Ground the Product. This product is grounded through the grounding conductor of the power cord. To avoid electric shock, the grounding conductor must be connected to earth ground. Before making connections to the input or output terminals of the product, ensure that the product is properly grounded.

Observe All Terminal Ratings. To avoid fire or shock hazard, observe all ratings and markings on the product. Consult the product manual for further ratings information before making connections to the product.

The common terminal is at ground potential. Do not connect the common terminal to elevated voltages.

Do not apply a potential to any terminal, including the common terminal, that exceeds the maximum rating of that terminal.

Do Not Operate Without Covers. Do not operate this product with covers or panels removed.

Use Proper Fuse. Use only the fuse type and rating specified for this product.

Avoid Exposed Circuitry. Do not touch exposed connections and components when power is present.

Do Not Operate With Suspected Failures. If you suspect there is damage to this product, have it inspected by qualified service personnel.

Do Not Operate in Wet/Damp Conditions.

Do Not Operate in an Explosive Atmosphere.

Keep Product Surfaces Clean and Dry.

Provide Proper Ventilation. Refer to the manual's installation instructions for details on installing the product so it has proper ventilation.

Symbols and Terms

Terms in this Manual. These terms may appear in this manual:



WARNING. *Warning statements identify conditions or practices that could result in injury or loss of life.*



CAUTION. *Caution statements identify conditions or practices that could result in damage to this product or other property.*

Terms on the Product. These terms may appear on the product:

DANGER indicates an injury hazard immediately accessible as you read the marking.

WARNING indicates an injury hazard not immediately accessible as you read the marking.

CAUTION indicates a hazard to property including the product.

Symbols on the Product. The following symbols may appear on the product:



WARNING
High Voltage



Protective Ground
(Earth) Terminal



CAUTION
Refer to Manual



Double
Insulated

Service Safety Summary

Only qualified personnel should perform service procedures. Read this *Service Safety Summary* and the *General Safety Summary* before performing any service procedures.

Do Not Service Alone. Do not perform internal service or adjustments of this product unless another person capable of rendering first aid and resuscitation is present.

Disconnect Power. To avoid electric shock, disconnect the mains power by means of the power cord or, if provided, the power switch.

Use Caution When Servicing the CRT. To avoid electric shock or injury, use extreme caution when handling the CRT. Only qualified personnel familiar with CRT servicing procedures and precautions should remove or install the CRT.

CRTs retain hazardous voltages for long periods of time after power is turned off. Before attempting any servicing, discharge the CRT by shorting the anode to chassis ground. When discharging the CRT, connect the discharge path to ground and then the anode. Rough handling may cause the CRT to implode. Do not nick or scratch the glass or subject it to undue pressure when removing or installing it. When handling the CRT, wear safety goggles and heavy gloves for protection.

Use Care When Servicing With Power On. Dangerous voltages or currents may exist in this product. Disconnect power, remove battery (if applicable), and disconnect test leads before removing protective panels, soldering, or replacing components.

To avoid electric shock, do not touch exposed connections.

X-Radiation. To avoid x-radiation exposure, do not modify or otherwise alter the high-voltage circuitry or the CRT enclosure. X-ray emissions generated within this product have been sufficiently shielded.

Calendar (date and time) Backup Battery. This product contains a Lithium:poly-carbon monofluoride battery for calendar backup purposes. This battery is not user replaceable.

Preface

This is the service manual for the AWG610 Arbitrary Waveform Generator. The manual contains information needed to service the waveform generator to the module level.

Manual Structure

This manual is divided into sections, such as *Specifications* and *Theory of Operation*. Further, some sections are divided into subsections, such as *Product Description* and *Removal and Installation Procedures*.

Sections containing procedures also contain introductions to those procedures. Be sure to read these introductions because they provide information needed to do the service correctly and efficiently. The following contains a brief description of each manual section.

- H *Specifications* contains a description of the waveform generator and the characteristics that apply to it.
- H *Operating Information* includes general information and operating instructions.
- H *Theory of Operation* contains circuit descriptions that support service to the module level.
- H *Performance Verification* contains procedures for confirming that the waveform generator functions properly and meets warranted limits.
- H *Adjustment Procedures* contains a statement explaining that adjustment is unnecessary for the waveform generator.
- H *Maintenance* contains information and procedures for performing preventive and corrective maintenance of the waveform generator. These instructions include cleaning, module removal and installation, and fault isolation to the module.
- H *Options* contains information on servicing factory-installed options.
- H *Electrical Parts List* contains a statement referring you to *Mechanical Parts List*, where both electrical and mechanical modules are listed.
- H *Diagrams* contains block diagrams and an interconnection diagram.
- H *Mechanical Parts List* includes a table of all replaceable modules, their descriptions, and their Tektronix part numbers.

Manual Conventions

This manual uses certain conventions that you should become familiar with.

Some sections of the manual contain procedures for you to perform. To keep those instructions clear and consistent, this manual uses the following conventions:

- H Names of front panel controls and menus appear in the same case (initial capitals, all uppercase, etc.) in the manual as is used on the waveform generator front panel and menus. Front panel names are all upper-case letters; for example, SETUP, UTILITY, HARDCOPY etc.
- H Instruction steps are numbered unless there is only one step.

Modules Throughout this manual, any replaceable component, assembly, or part of the waveform generator is referred to generically as a module. In general, a module is an assembly (like a circuit board), rather than a component (like a resistor or an integrated circuit). Sometimes a single component is a module; for example, the chassis of the waveform generator is a module.

Safety Symbols and terms related to safety appear in the *Safety Summary* near the beginning of this manual.

Finding Other Information

Other documentation for the AWG610 Arbitrary Waveform Generator includes:

- H The AWG610 Arbitrary Waveform Generator *User Manual* contains a tutorial to quickly describe how to operate the waveform generator. It also includes an in-depth discussion on how to more completely use the waveform generator features.
- H The AWG610 Arbitrary Waveform Generator *Programmer Manual* explains how to use a GPIB interface to remotely control the waveform generator.

Contacting Tektronix

Product Support	<p>For application-oriented questions about a Tektronix measurement product, call toll free in North America: 1-800-TEK-WIDE (1-800-835-9433 ext. 2400) 6:00 a.m. - 5:00 p.m. Pacific time</p> <p>Or contact us by e-mail: tm_app_supp@tektronix.com</p> <p>For product support outside of North America, contact your local Tektronix distributor or sales office.</p>
Service Support	<p>Contact your local Tektronix distributor or sales office. Or visit our web site for a listing of worldwide service locations.</p> <p>http://www.tektronix.com</p>
For other information	<p>In North America: 1-800-TEK-WIDE (1-800-835-9433) An operator will direct your call.</p>
To write us	<p>Tektronix, Inc. P.O. Box 1000 Wilsonville, OR 97070-1000</p>

Introduction

This manual contains information needed to properly service the AWG610 Arbitrary Waveform Generator Arbitrary Waveform Generators, as well as general information critical to safe and effective servicing.

To prevent personal injury or damage to the waveform generator, consider the following before attempting service:

- H The procedures in this manual should be performed only by a qualified service person
- H Read the *General Safety Summary* and the *Service Safety Summary*, beginning on page ix
- H Read *Preparation for Use* in section 2, *Operating Information*

When using this manual for servicing, be sure to follow all warnings, cautions, and notes.

Performance Verification Procedures

Generally, the performance check described in the *Performance Verification* section, should be done every 12 months. In addition, a performance check is recommended after module replacement.

If the waveform generator does not meet performance criteria, repair is necessary.

Strategy for Servicing

Throughout this manual, the term, module, refers to any field-replaceable component, assembly, or part of the waveform generator.

This manual contains all the information needed for periodic maintenance of the waveform generator. Further, it contains all information for corrective maintenance down to the module level. To isolate a failure to a module, use the troubleshooting procedures found in the *Maintenance* section. To remove and replace any failed module, follow the instructions in the *Removal and Installation Procedures* section. After isolating a faulty module, replace it with a fully-tested module obtained from the factory. The *Replaceable Mechanical Parts* section contains part number and ordering information for all replaceable modules.

Tektronix Service Offerings

Tektronix provides service to cover repair under warranty as well as other services that may provide a cost-effective answer to your service needs.

Whether providing warranty repair service or any of the other services listed below, Tektronix service technicians are well trained to service the waveform generator. They have access to the latest information on improvements to the AWG610 Arbitrary Waveform Generator as well as new options.

Warranty Repair Service

Tektronix warrants this product for one year from date of purchase. The warranty appears on the back of the title page in this manual. Tektronix technicians provide warranty service at most Tektronix service locations. The Tektronix product catalog lists all worldwide service locations.

Self Service

Tektronix supports repair to the module level by providing Module Exchange.

Module Exchange. This service reduces down-time for repair by allowing you to exchange most modules for re-manufactured ones. Each module comes with a 90-day service warranty.

For More Information. Contact your local Tektronix service center or sales engineer for more information on any of the repair or adjustment services just described.



Specifications

Product Overview

Product Description

The AWG610 Arbitrary Waveform Generator is a waveform generator that can generate simple and arbitrary waveforms and generates one-channel differential output arbitrary waveforms and function generator waveforms.

The AWG610 Arbitrary Waveform Generator allows you to create sine, triangle, square, ramp, and complex waves, as well as direct current and noises signals. It allows you to set waveform attributes such as frequency, amplitude, and offset.

This instrument contains a hard disk drive, a 3.5-inch floppy disk drive, and Ethernet interface for storing and recalling waveform data and instrument settings.

You can remotely control the instrument by sending commands through both the GPIB and 10BASE-T interfaces, as well as transfer waveform data directly from a digital storage oscilloscope to the waveform generator instrument using the GPIB and 10BASE-T interfaces. This enables you to use the instrument in combination with other measurement equipment and a computer.

Main Features

The AWG610 Arbitrary Waveform Generator contains the following main features:

- H 2.6 GHz clock frequency
- H 8-bit DA converter
- H 8 M-word waveform memory
- H Two arbitrary marker outputs
- H Five waveform editors (see Table 1-1)

Table 1-1: AWG610 waveform editors

Editor	Description
Waveform	Creates analog waveform data in graphic or tabular form.
Pattern	Creates analog waveform data in timing and table form.
Sequence	Creates sequences of waveforms by combining the waveform files created with the Waveform and/or Pattern Editors.
Text	Edits plain ASCII-format waveform files. For example, you can use the Text editor to edit ASCII-format waveform files that are read from an external device.
Equation	Creates files with equations and compiles them into waveform files.

Additional Features

The AWG610 Arbitrary Waveform Generator provides the following additional features:

- H Provides an Ethernet port for using the NFS (Network File System) and/or FTP link. Refer to the Reference: *Ethernet Networking* section in the AWG610 Arbitrary Waveform Generator User Manual.
- H Provides a GPIB interface that can be used for remotely controlling the AWG610 Arbitrary Waveform Generator and for transferring the waveform data from the external oscilloscopes.

Refer to *Connecting to a GPIB Network of The UTILITY Window* of section 3 Reference on AWG610 Arbitrary Waveform Generator User Manual for information on setting the GPIB parameters.

Refer to the AWG610 Arbitrary Waveform Programmer Manual for information on the remote control commands.

Refer to the *Reference: Capturing Waveforms* section of the AWG610 Arbitrary Waveform Generator User Manual for transferring waveforms from the external oscilloscopes to the waveform generator.

- H Provides a port on the rear panel, for connecting a 101 or 106 type keyboard to the AWG610 Arbitrary Waveform Generator. You can input values or text, with the keyboard instead of using the numeric keypad on the front-panel. Refer to the *Reference: External Keyboards* section of the AWG610 Arbitrary Waveform Generator User Manual.
- H Provides an internal clock for setting up the current date and time. Refer to *Internal Clock (Date and Time)* in the AWG610 Arbitrary Waveform Generator User Manual. This setup procedure is also described in the *Operating Basics: Tutorial 1* section of the AWG610 Arbitrary Waveform Generator User Manual.

- H Provides an adjustment for controlling the CRT brightness. Refer to the *Reference :CRT Brightness* section of the AWG610 Arbitrary Waveform Generator User Manual. This setup procedure is also described in *Operating Basics:Tutorial 1* section of the AWG610 Arbitrary Waveform Generator User Manual.

Specifications

This section contains the AWG610 Arbitrary Waveform Generator specifications. All specifications are guaranteed unless labeled “typical”. Typical specifications are provided for your convenience but are not guaranteed.

Specifications that are marked with the \square symbol in the column Characteristics are checked in *Appendix B: Performance Verification* and the page number referenced to the corresponding performance verification procedures can be found in the column PV reference page.

The characteristics in the specifications are listed in tables that are divided into categories. In these tables, the subcategories may also appear in boldface under the column Characteristics.

Performance Conditions

The performance limits in this specification are valid with these conditions:

- H The AWG610 Arbitrary Waveform Generator must have been calibrated/adjusted at an ambient temperature between +20_ C and +30_ C.
- H The AWG610 Arbitrary Waveform Generator must be in an environment with temperature, altitude, humidity, and vibration within the operating limits described in these specifications.
- H The AWG610 Arbitrary Waveform Generator must have had a warm-up period of at least 20 minutes.
- H The AWG610 Arbitrary Waveform Generator must be operating at an ambient temperature between +10_ C and +40_ C.

Warranted characteristics are described in terms of quantifiable performance limits which are warranted.

Electrical Specification

Table 1-2: Operation modes

Characteristics	Description
Continuous	Waveform is continuously output in this mode. When a sequence is defined, waveforms are sequentially or repeatedly output in the order defined by the sequence. The extended sequence functions such as trigger input, event jump, and so on are neglected in this mode.
Triggered	Waveform is output only once when a trigger event is created. A trigger signal is created by the external trigger input signal, GPIB trigger command, and/or pressing the front-panel FORCE TRIGGER button. The extended sequence functions such as trigger input, event jump, and so on are neglected in this mode.
Gated	The waveform is output in the same way as in the continuous mode only when the gate is opened. The gate is opened by the gated signal. Note that the output is made from the top of the first waveform for every gate period. The clock signal continuously outputs from the connector outside the gate period.
Enhanced	The waveforms are sequentially or repeatedly output according to the procedures defined in the sequence. All extended functions such as trigger input, event jump, and so on are effective and waveforms are controlled for output by this functions in this mode.

Table 1-3: Arbitrary waveforms

Characteristics	Description
Waveform memory	Memory length: 8,100,032 words (8 bits/1 word)
Marker memory	Memory length: 8,100,032 words (2 markers × 1 bit / 1 word)
Sequence memory	Maximum 8000 steps
Sequence counter	1 to 65,536 or Infinite
Waveform data points	Multiple of 8 in the range from 512 to 8,100,032 points

Table 1-4: Clock generator

Characteristics	Description	PV reference page
Sampling frequency	50.000 000 kHz to 2.600 000 0 GHz	
Resolution	8 digits	

Table 1-4: Clock generator (Cont.)

Characteristics	Description	PV reference page
Internal clock ¹		
n Frequency accuracy	± 1 ppm (20 °C to 30 °C), during 1 year after calibration	Page 4-50
Phase noise at 1/4 clock output, Typical	(Data Clock is 1/4th of the output sample rate) -80 dBc / Hz (650 MHz with 10 kHz offset) -100 dBc/Hz (650 MHz with 100 kHz offset)	

¹ The internal reference oscillator is used.

Table 1-5: Internal trigger generator

Characteristics	Description	PV reference page
Internal trigger rate ²		
n Accuracy	± 0.1 %	Page 4-38
Range	1.0 μ s to 10.0 s	
Resolution	3 digits, minimum 0.1 μ s	

² The internal reference oscillator is used.

Table 1-6: Main output

Characteristics	Description	PV reference page
Output connector	front-panel SMA connectors	
Output signal	Complemental; CH1 and $\overline{\text{CH1}}$	
DA converter		
Resolution	8 bits	
Differential nonlinearity	Within $\pm 1/2$ bit	
Integral nonlinearity	Within ± 1 bit	
Output impedance	50 Ω	
Normal out		
Output voltage	-2.0 V to +2.0 V, into a 50 Ω load	
Amplitude		
Range	20 mV _{p-p} to 2 V _{p-p} , into a 50 Ω load	
Resolution	1 mV	
n DC accuracy	$\pm (1.5$ % of amplitude + 2 mV), offset: 0 V	Page 4-24
Offset		
Range	-1.000 V to 1.000 V, into a 50 Ω load	

Specifications

Table 1-6: Main output (Cont.)

Characteristics ³	Description	PV reference page
Resolution	1 mV	
Accuracy	$\pm (1 \% \text{ of offset} + 10 \text{ mV})$, (20 mV amplitude, waveform data: 0)	Page 4-24
Pulse response	(Waveform data: -1 and 1, offset: 0 V, and filter: through)	Page 4-34
Rise time (10 % to 90 %)	$\leq 750 \text{ ps}$ (amplitude = 1.0 V _{p-p} , calculated value $\geq 466 \text{ MHz}$)	
Fall time (10 % to 90 %)	$\leq 750 \text{ ps}$ (amplitude = 1.0 V _{p-p} , calculated value $\geq 466 \text{ MHz}$)	
Aberration	$\pm 10 \%$ (amplitude = 1.0 V _{p-p} , using 6 GHz bandwidth oscilloscope)	
Flatness	$\pm 3 \%$ (after 20 ns from rise and fall edges)	
Sinewave characteristics	(Clock: 2.6 GS/s, waveform points: 32, frequency: 81.25 MHz, amplitude: 1.0 V, offset: 0 V, filter: through)	
Harmonics	$\leq -40 \text{ dBc}$ (DC to 800 MHz)	Page 4-36
Noise	$\leq -50 \text{ dBc}$ (DC to 800 MHz)	
Phase Noise, Typical	$\leq -85 \text{ dBc / Hz}$ (10 kHz offset)	
Direct DA out		
Amplitude		
Range	20 mV _{p-p} to 1 V _{p-p} , into a 50 Ω load	
Accuracy	$\pm (2 \% \text{ of Amplitude} + 2 \text{ mV})$	Page 4-29
Resolution	1 mV	
DC offset accuracy	0 V \pm 10 mV, (20 mV amplitude, waveform data: 0)	Page 4-29
Pulse response	(Waveform data: -1 and 1, at 0.5 V _{p-p})	Page 4-34
Rise time (10 % to 90 %)	$\leq 400 \text{ ps}$ (calculated value $\geq 875 \text{ MHz}$)	
Fall time (10 % to 90 %)	$\leq 400 \text{ ps}$ (calculated value $\geq 875 \text{ MHz}$)	

³ The characteristics are specified at the end of the SMA cable (012-1565-00) except for DC accuracy.

Table 1-7: Filter

Characteristics	Description	
Type	Bessel low pass filter, 200 MHz, 100 MHz, 50 MHz, and 20 MHz	
Rise time (20 % to 80 %), Typical	20 MHz 50 MHz 100 MHz 200 MHz	17 ns 7.0 ns 3.5 ns 1.75 ns
Delay from trigger, Typical	20 MHz 50 MHz 100 MHz 200 MHz Through	50 ns + 22 clock 40 ns + 22 clock 35 ns + 22 clock 33 ns + 22 clock 30 ns + 22 clock

Specifications

Table 1-8: Auxiliary outputs

Characteristics	Description	PV reference page
Marker ⁴		
Number of markers	2 (Complementary. Marker1, $\overline{\text{Marker1}}$, Marker2, $\overline{\text{Marker2}}$)	
Level (Hi/Lo)	-1.10 V to +3.00 V, into a 50 Ω load -2.20 V to +6.00 V, into a 1 M Ω load	
Maximum Output	2.5 V _{p-p} , into a 50 Ω load	
Resolution	0.05 V	
n Accuracy	Within \pm (0.1 V +5 % of setting), into a 50 Ω load	Page 4-56
Rise and fall times (20 % to 80 %), Typical	150 ps (2 V _{p-p} , Hi: +1 V, Lo: -1 V, into a 50 Ω load)	
Variable delay		
n Range	0 ns to +1.5 ns	Page 4-59
n Accuracy	-30 % to +10%, at 1.5 ns setting	
Resolution	100 ps	
Skew, Typical	70 ps (2 V _{p-p} , Hi: +1 V, Lo: -1 V, at delay 0 ns)	
Period jitter Typical	Measured by TDS694C-1MHD with TDSJIT1 Refer to Table 1-9.	
Cycle to cycle jitter Typical	Measured by TDS694C-1MHD with TDSJIT1 Refer to Table 1-10.	
Connector	Front panel SMA connectors	
1/4 Clock output		
n Level	ECL 100 K compatible (internally loaded in 50 Ω to -2 V and 43 Ω series terminated)	Page 4-52
Period jitter Typical	Measured by TDS694C-1MHD with TDSJIT1 Refer to Table 1-9.	
Cycle to cycle jitter Typical	Measured by TDS694C-1MHD with TDSJIT1 Refer to Table 1-10.	
Connector	Rear panel BNC connectors	
10 MHz Reference clock out		
n Amplitude	\geq 1 V _{p-p} , into a 50 Ω load Max 3 V _{p-p} , open	Page 4-54
Impedance	50 Ω , AC coupling	
Connector	Rear panel BNC connector	

⁴ The characteristics are specified at the end of the SMA cable (012-1565-XX).

Table 1-9: Period Jitter

Clock frequency	2.6 GS/s		1.6 GS/s		800 MS/s	
	StdDev	Pk-Pk	StdDev	Pk-Pk	StdDev	Pk-Pk
Measurement	3.5 ps	16.0 ps	3.5 ps	16.0 ps	3.0 ps	14.0 ps
Marker1 output	4.5 ps	25.0 ps	4.5 ps	25.0 ps	4.0 ps	23.0 ps

Table 1-10: Cycle to Cycle Jitter

Clock frequency	2.6 GS/s		1.6 GS/s		800 MS/s	
	StdDev	Pk-Pk	StdDev	Pk-Pk	StdDev	Pk-Pk
Measurement	5.5 ps	28.0 ps	5.5 ps	28.0 ps	5.5 ps	28.0 ps
Marker1 output	6.5 ps	37.0 ps	6.5 ps	37.0 ps	6.5 ps	37.0 ps

Table 1-11: Auxiliary inputs

Characteristics	Description	PV reference page
Trigger input ⁵		
Connector	Rear panel BNC connector	
Impedance	1 k Ω or 50 Ω	
Polarity	POS (positive) or NEG (negative)	
Input voltage range	± 10 V, into a 1 k Ω load ± 5 V, into a 50 Ω load	
Threshold		
Level	-5.0 V to 5.0 V	
σ Accuracy	$\pm (5\% \text{ of level} + 0.1 \text{ V})$	Page 4-40
Resolution	0.1 V	
Pulse width	Minimum 10 ns, 0.2 V amplitude	
Trigger dead time	$\leq 576 \text{ clock} + 450 \text{ ns}$	
Delay to analog out, Typical	30 ns +22 clock (Triggered mode) 30 ns +880 clock (Gated mode)	
Delay to marker, Typical	28 ns +22 clock	

Specifications

Table 1-11: Auxiliary inputs (Cont.)

Characteristics	Description	PV reference page
Event trigger input		
Connector	9-pin, D type on the rear panel	
Number of events	4 bits	
Input signal	4 event bits and Strobe	
Threshold	TTL level	
Impedance	2.2 k Ω , pull-up to +5 V	
Pulse width	Minimum 128 clocks	
Input voltage range	0 V to +5 V (DC + peak AC)	
Delay to analog out, Typical	850 clock +20 ns (Jump timing : ASYNC)	
Reference 10 MHz clock input		
Input voltage range	0.2 V to 3.0 V _{p-p} (into a 50 Ω load, AC coupling) Maximum ± 10 V	
Impedance	50 Ω , AC coupling	
Reference frequency	10 MHz \pm 0.1 MHz	
Connector	Rear panel BNC connector	

⁵ The characteristics are specified at the end of the BNC cable (012-0482-00).

Table 1-12: Display and timer

Characteristics	Description
Display	
Display area	Horizontal: 13.2 cm (5.2 in)
	Vertical: 9.9 cm (3.9 in)
Resolution	640 (H) \times 480 (V) pixels

Table 1-13: AC line power

Characteristics	Description
Rating voltage	100 to 240 VAC
Voltage range	90 to 250 VAC
Frequency range	48.0 Hz to 63 Hz
Maximum consumption	400 W
Maximum current	5 A
Fuse rating	10 A fast, 250 V, UL 198G (3 AG) 5 A (T), 250 V, IEC 127

Table 1-14: Timer

Characteristics	Description
Timer	
Operation life	6 years
Type	Li 3 V, 190 mAh

Table 1-15: Interface connectors

Characteristics	Description
GPIO	24-pin, IEEE 488.1 connector on the rear panel
Ethernet	10 BASE-T, RJ-45 connector on the rear panel
Keyboard connector	6-pin, mini-DIN connector on the rear panel

Table 1-16: Installation requirement

Characteristics	Description
Heat dissipation	
Maximum power	400 W (maximum line current: 5 A _{rms} , at 50 Hz)
Surge current	30 A (25 °C) peak for equal to or less than 5 line cycles, after the instrument has been turned off for at least 30s
Cooling clearance	Bottom 2 cm (0.8 in) <i>NOTE: The feet on the bottom provide the required clearance when set on a flat surface.</i>
	Sides 15 cm (6 in)
	Rear 7.5 cm (3 in)

Specifications

Table 1-17: Environmental

Characteristics	Description
Atmospherics	
Temperature	
Operating	+10 _C to +40 _C
Nonoperating	-20 _C to +60 _C
Relative humidity	
Operating	20 % to 80 % (no condensation) Maximum wet-bulb temperature 29.4 _C
Nonoperating	5 % to 90 % (no condensation) Maximum wet-bulb temperature 40.0 _C
Altitude	(Hard disk drive restriction)
Operating	Up to 3 km (10 000 ft) Maximum operating temperature decreases 1 _C each 300 m (1 000 ft) above 1.5 km (5,000 ft)
Nonoperating	Up to 12 km (40,000 ft)
Dynamics	
Random vibration	
Operating	0.27 g rms, from 5 Hz to 500 Hz, 10 minutes
Nonoperating	2.28 g rms, from 5 Hz to 500 Hz, 10 minutes
Shock	
Nonoperating	294 m/s ² (30 G), half-sine, 11 ms duration

Table 1-18: Mechanical

Characteristics	Description
Net weight (without package)	17 kg (37.5 lb)
Dimensions (without package)	Height 178 mm (7.0 in) 194 mm (7.64 in) with Feet
	Width 422 mm (16.6 in) 434 mm (17.1 in) with Handle
	Length 560 mm (22.0 in) 602 mm (23.71 in) with Rear Feet
Net weight (with package)	25 kg (55.2 lb)
Dimensions (with package)	Height 370 mm (14.6 in)
	Width 560 mm (22.0 in)
	Length 805 mm (31.7 in)

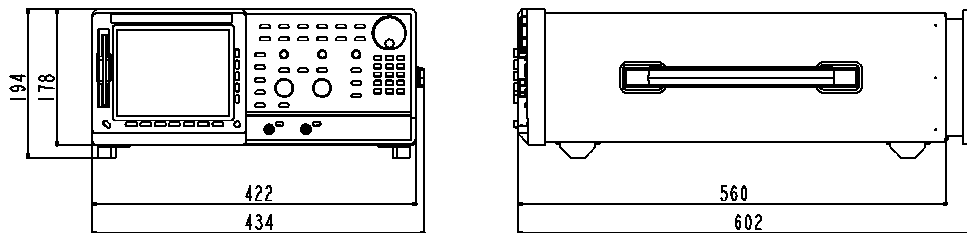

[mm]

Figure 1-1: Dimensions

Certification and Compliances

The certification and compliances for the AWG610 Arbitrary Waveform Generator are listed in Table 1-19.

Table 1-19: Certifications and compliances

<p>EC declaration of conformity</p>	<p>Meets intent of Directive 89/336/EEC for Electromagnetic Compatibility. Compliance was demonstrated to the following specifications as listed in the Official Journal of the European Communities:</p> <p>EN 50081-1 Emissions: EN 55011 Class A Radiated and Conducted Emissions EN 61000-3-2 AC Power Line Harmonic Emissions</p> <p>EN 50082-1 Immunity: EN 61000-4-2 Electrostatic Discharge Immunity EN 61000-4-3 RF Electromagnetic Field Immunity EN 61000-4-4 Electrical Fast Transient Immunity EN 61000-4-5 Surge Immunity EN 61000-4-6¹ Conducted Disturbances Induced by RF Fields EN 61000-4-8 Power Frequency Electromagnetic Field EN 61000-4-11 Power Line Interruption Immunity</p> <p>Compliance was demonstrated to the following specification as listed in the Official Journal of the European Communities:</p> <p>Low Voltage Directive 73/23/EEC</p> <p>EN 61010-1:1993 Safety requirements for electrical equipment for measurement, control, and laboratory use</p>
<p>Australian declaration of conformity - EMC \</p>	<p>Conforms with the following standards in accordance with the Electromagnetic Compatibility Framework:</p> <p>AS/NZS 2064.1/2 Class A radiated and Conducted Emissions</p>
<p>Safety</p> <p style="padding-left: 20px;">Third party certification</p> <p style="padding-left: 20px;">Self declaration</p>	<p>UL3111-1² - Standard for electrical measuring and test equipment</p> <p>CAN/CSA C22.2 No. 1010.1² - Safety requirements for electrical equipment for measurement, control and laboratory use</p> <p>EN 61010-1² - Safety requirements for electrical equipment for measurement, control, and laboratory use</p>

¹ Up to 200 mV_{p-p} noise is allowed on the output during this test.

² CSA C22.2 No. 1010.1, UL3111-1, EN 61010-1 Safety certification compliance:
 Altitude (maximum operating) : 2000 meters

Table 1-19: Certifications and compliances (cont.)

Installation category	Power input — Installation Category II (as defined in IEC 1010-1, Annex J)	
	<i>Category</i>	<i>Descriptions</i>
	CAT III	Distribution-level mains (usually permanently connected). Equipment at this level is typically in a fixed industrial location
	CAT II	Local-level mains (wall sockets). Equipment at this level includes appliances, portable tools, and similar products. Equipment is usually cord-connected
	CAT I	Secondary (signal level) or battery operated circuits of electronic equipment
Pollution degree	Pollution Degree 2 (as defined in IEC 1010-1)	
	Do not operate in environments where conductive pollutant may be present.	



Operating Information

Preparation for Use

This subsection provides the following information:

- H *Supplying Operating Power*
- H *Operating Environment*
- H *Applying and Interrupting Power*
- H *Repackaging Instructions*

Supplying Operating Power



WARNING. To avoid equipment failure and potential fire or personal shock hazards, do not exceed the maximum rated operating voltage of 250 V between the voltage-to-ground (earth) and either pole of the power source. The AWG610 Arbitrary Waveform Generator operates from a single-phase power source and has a three-wire power cord with a two-pole, three-terminal grounding plug. Also, before making connection to the power source, be sure the AWG610 Arbitrary Waveform Generator has a suitable two-pole, three-terminal grounding-type plug.

To avoid personal shock hazard, do not touch conductive parts. All accessible conductive parts are directly connected through the grounding conductor of the power cord to the grounded (earth) contact of the power plug. The AWG610 Arbitrary Waveform Generator is safety Class 1 equipment (IEC designation).



WARNING. To prevent electrical shock, remove all power from the instrument, turn the **PRINCIPAL POWER SWITCH** on the back panel to OFF, and disconnect the power cord from the instrument. Some components in the AWG610 Arbitrary Waveform Generator are still connected to line voltage after turning off the instrument from the front-panel **ON/STBY** button.

Power Cord Information

A power cord with the appropriate plug configuration is supplied with each AWG610 Arbitrary Waveform Generator. Table 2-1 gives the color-coding of the conductors in the power cord. If you require a power cord other than the one supplied, refer to Table 2-2.

Table 2-1: Power-cord conductor identification

Conductor	Color	Alternate Color
Ungrounded (Line)	Brown	Black
Grounded (Neutral)	Light Blue	White
Grounded (Earthing)	Green/Yellow	Green

Table 2-2: Power cord identification

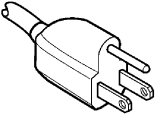
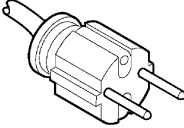
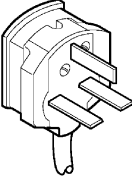
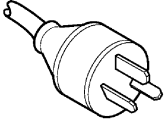
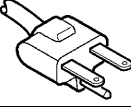
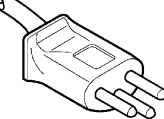
Plug Configuration	Normal Usage	Option Number
	North America	Standard
	Europe	A1
	United Kingdom	A2
	Australia	A3
	North America	A4
	Switzerland	A5

Operating Voltage

This AWG610 Arbitrary Waveform Generator operates with any line voltage from 100 to 240 VAC_{RMS} with any line frequency from 48 to 63 Hz. There are two fuses, either of which may be used throughout the line voltage and frequency

ranges. (The two fuses are not interchangeable as each requires a different fuse cap.)

Memory Backup Power

Memory modules with on-board batteries allow the AWG610 Arbitrary Waveform Generator to retain only internal clock of data upon loss of the AC power source.

To set the date and time in the waveform generator, see the *Reference:Internal Clock (Date and Time)* section of the AWG610 Arbitrary Waveform Generator User Manual.

Operating Environment

The following environmental requirements are provided to ensure proper operation and long instrument life.

Operating Temperature

Operate the waveform generator where the ambient air temperature is from 10_ C to +40_ C. Store the waveform generator in ambient temperatures from -20_ C to +60_ C. After storage at temperatures outside the operating limits, allow the chassis to stabilize to a safe operating temperature before applying power.

Ventilation Requirements

The waveform generator is cooled by air drawn in and exhausted through the cabinet side panels by an internal fan. To ensure proper cooling of the waveform generator, allow at least 15 cm (6 inches) clearance on both sides, 0.8 inches (2 cm) on the bottom, and 7.5 cm (3 inches) on the rear of the waveform generator. (The feet on the bottom of the waveform generator provide the required clearance when set on flat surfaces.)



CAUTION. *When the air flow is restricted and the temperature of the DAC module surface goes over 80_ C, the AWG610 Arbitrary Waveform Generator may temporarily shut down to protect the internal modules. To prevent temporary shutdown of the AWG610 Arbitrary Waveform Generator, do not restrict air flow through the chassis.*

The AWG610 Arbitrary Waveform Generator displays the message “Power fail or out of temperature limit” before shutting down.

If the AWG610 Arbitrary Waveform Generator shuts down unexpectedly, improve ventilation around the AWG610 Arbitrary Waveform Generator and wait a few minutes to allow it to cool down; then switch the power on again.

Applying and Interrupting Power

Consider the following information when you power on or power off the instrument, or when power is interrupted due to an external power failure.

Power On Upon power on, the waveform generator runs a power-on self check. If it passes, the AWG610 Arbitrary Waveform Generator displays a *Pass* status message and a prompt to press any key to continue. If it fails, the AWG610 Arbitrary Waveform Generator displays a diagnostic log that identifies the area(s) that failed and a prompt to press any key to continue. Refer to the *Maintenance* section for information on diagnostics and fault isolation.

Power Off



CAUTION. *DO NOT* power off the waveform generator when either running a signal path compensation or when doing any of the adjustments described in the Adjustment Procedures section. To do so might result in the loss of internally stored adjustment constants.

In general, do not power off the instrument when doing operations that affect the data stored in the memory. Wait for the instrument to finish the operation when doing adjustments, saving waveforms, or saving setups.

Improper power off or unexpected loss of power to the AWG610 Arbitrary Waveform Generator can result in calibration data corruptions on the hard disk.

Repackaging Instructions

Use a corrugated cardboard shipping carton having a test strength of at least 375 pounds and with an inside dimension at least six inches greater than the instrument dimensions.

If the instrument is being shipped to a Tektronix Service Center, enclose the following information: the owner's name, address, phone number of a contact person, type and serial number of the instrument, reason for returning, and a complete description of the service required.

Seal the shipping carton with an industrial stapler or strapping tape.

Mark the address of the Tektronix Service Center and also your own return address on the shipping carton in two prominent locations.

Basic Operations

This section provides the following information:

- H *Menu System*
- H *Numeric Input*
- H *Text Input*
- H *Shortcut Controls*
- H *File Management*

Menu System

The AWG610 Waveform Generator uses menus to make selections. There are four menu buttons, labeled EDIT, SETUP, APPL, and UTILITY, as shown in Figure 2-1. Pushing a menu button displays the corresponding screen and menu buttons. These menus let you edit waveforms, initialize instrument settings, define instrument operation, and specify waveform output parameters.

You select items within the displayed menu by pushing the bottom or side bezel button nearest to the menu item. These buttons consist of seven bottom buttons and five side buttons, as shown in Figure 2-1. These menu bezel buttons are referred to as bottom menu buttons (or bottom buttons) and side menu buttons (or side buttons).

The **CLEAR MENU** button cancels the current menu operation, clears the current menus from the screen, and exits to the previous instrument state.

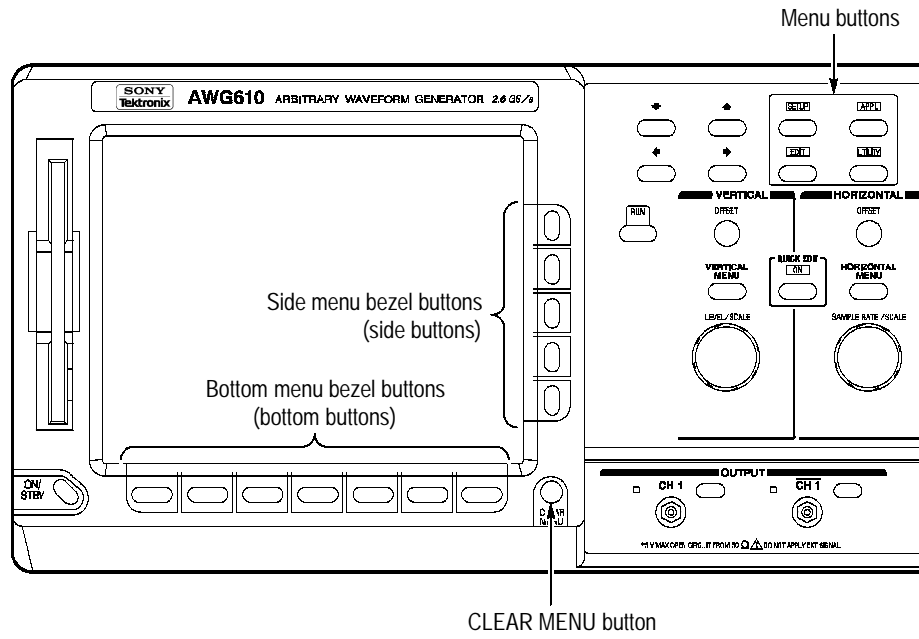

Figure 2-1: Menu buttons, bezel menu buttons, and the CLEAR MENU button

Menu Elements Pushing a front-panel menu button displays the screen and bottom menu items. You select a bottom menu item by pushing the button directly below that menu item.

Pushing a bottom button displays a side menu, pop-up menu, list, or dialog box. Figures 2-2 through 2-4 show examples of the side menu, pop-up menu and dialog box, respectively.

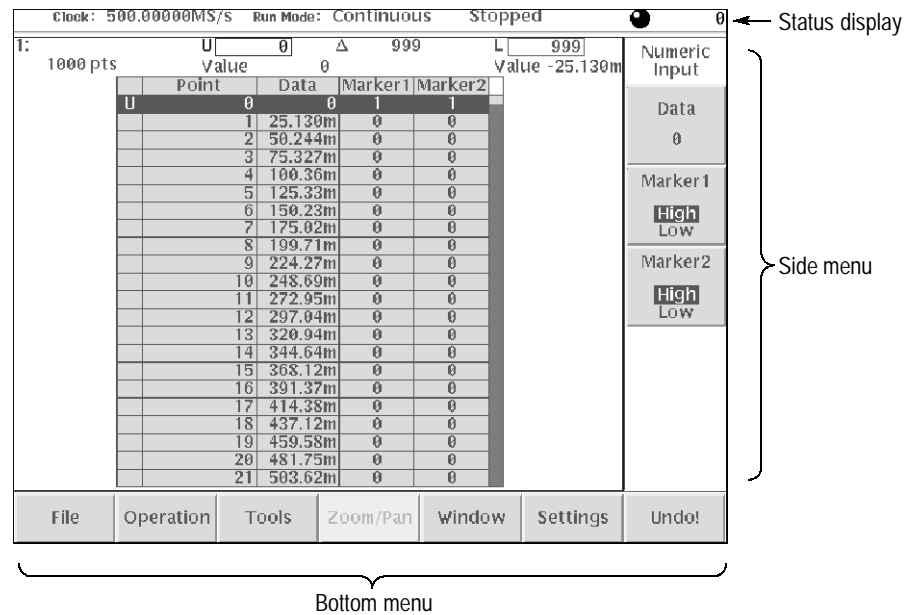

Figure 2-2: Bottom and side menus

You use a side menu button to display a side submenu, set a parameter, perform a task, or cancel an operation. Table 2-3 describes the side menu button types.

Table 2-3: Side menu elements

Menu items	Description	Menu items	Description
External	Executes the displayed function immediately.	Up Level	Cannot be used in the current instrument state (menu item is grayed out).
Output Normal Direct	Switches between two parameters each time the side button is pushed.	Filter 20 MHz	Allows making selections by using the general purpose knob.
Amplitude 1.000Vpp	Allows entering numeric values using the numeric buttons or the general purpose knob.	Marker...	Displays submenus. Note that the label on the item is followed by an ellipsis (...).

The pop-up menu example, shown in Figure 2-3, displays a list of choices from which you make a selection. Use the general purpose knob or the front-panel arrow buttons to move up or down in the list. Push the **OK** side button or the **ENTER** front-panel button to confirm the selected item.

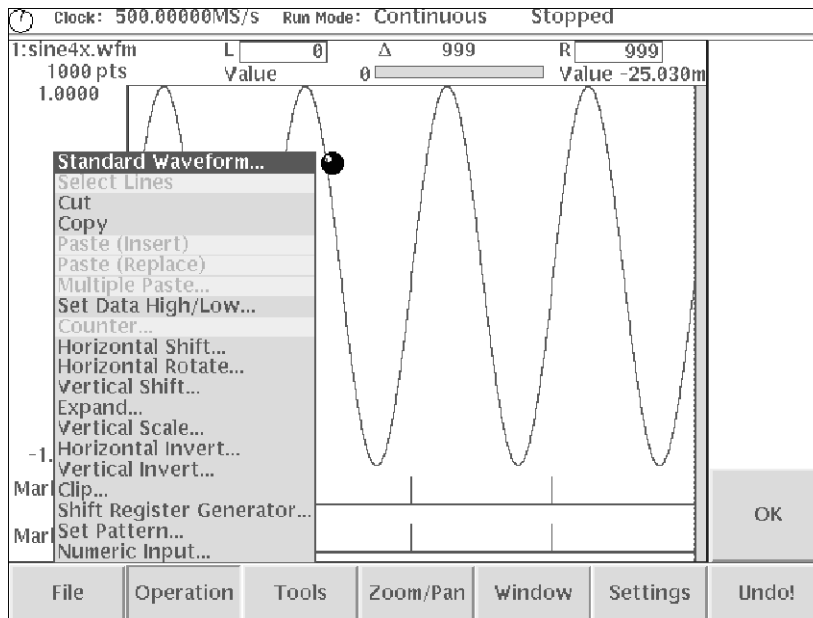

Figure 2-3: Pop-up menu example

The dialog box example, shown in Figure 2-4, displays a form in which you make selections or enter values. Use the front-panel arrow buttons to select items or fields. A selected field or item is highlighted. Use the keypad buttons or the general purpose knob to change values in selected text/numeric fields or change 1-of-N fields. A 1-of-N field contains two or more choices of which only one can be selected at a time.

Push the **OK** side button to confirm the dialog box. Push the **Cancel** side button or the **CLEAR MENU** button to exit the dialog box without making any changes.

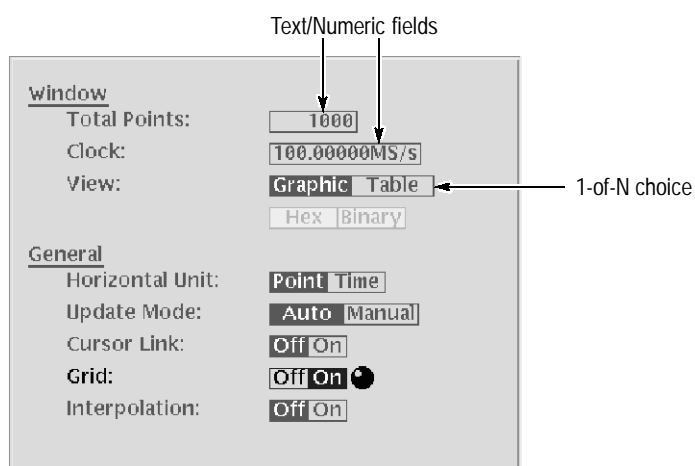

Figure 2-4: Dialog box example

Refer to the *Operating Information:Numeric Input* section on page 2-12 and the *Operating Information:Text Input* section on page 2-14 for more information on selecting and entering values in menus and dialog boxes.

Refer to the *Reference:Menu Structure* in the user manual for information on the menu system.

Numeric Input

You can enter numeric values by using either the numeric keypad or the general purpose knob. If the side menu item displays a value, you can alter this value using the general purpose knob or numeric buttons.

Pushing the type of side menu button or selecting a parameter in a pop-up menu causes the current setting to appear on the right end of the Status Display area as shown in Figure 2-5.

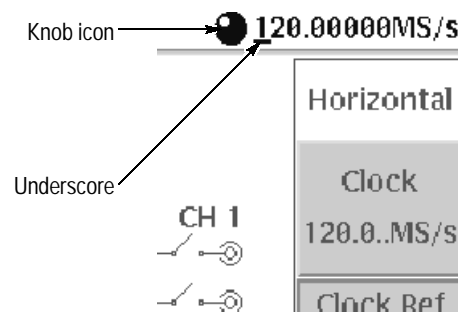

Figure 2-5: Knob icon displayed in status display area

The General Purpose Knob

A knob icon with a numeric value that includes an underscore character indicates that you can change the value at the underscore location by using the general purpose knob or keypad buttons. By default, the underscore character is positioned under the digit specified depending on the parameters. You can only change the value represented by the digits at and to the left of the underscore. Use the **a** and **'** arrow buttons to move the underscore to the desired position and then turn the general purpose knob to change the value.

If the numeric value has the knob icon, but does not have the underscore, then turning the general purpose knob cycles through a predefined set of values.

When using the general purpose knob, values you change in side menus and menu screens take effect immediately. Values in pop-up menus are not effective until you push the **OK** side button or the **ENTER** front-panel button.

The Numeric Keypad

Figure 2-6 shows the numeric keypad, with descriptions of the button operations.

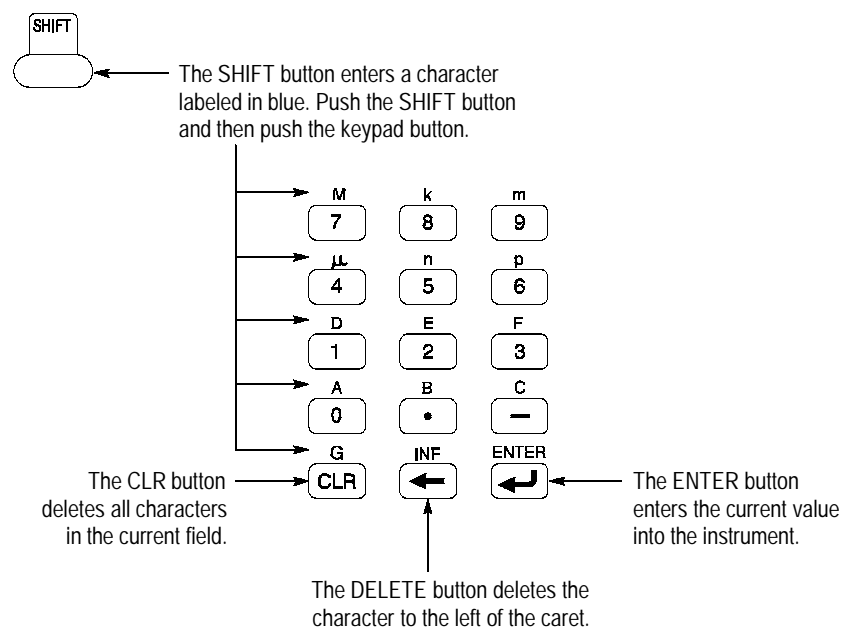

Figure 2-6: Keypad buttons

The G, M, k, m, μ , n, and p are unit buttons. The A, B, C, D, E, and F buttons are used for entering hexadecimal values.

To use the numeric keypad to enter a value, position the caret to where you want to change a value and then push a keypad button. If you want to enter a unit value labeled in blue just above each numeric button, push or hold down the **SHIFT** button and then push the corresponding numeric button.

To enter or change more than one character, move the caret to the next position to change. When you are done entering values, push the **ENTER** button to confirm the changes and enter them into the instrument. For example, to enter 200.5 μ s, push **2**, **0**, **0**, **.**, **5**, **m(SHIFT + 4)**, and **ENTER**.

When you enter a value larger than the maximum value in the range for the parameter, the parameter will be set to the maximum value. When you enter a value smaller than the minimum value, the minimum value will be set in the parameter. To set to the maximum or minimum value, enter a larger value or smaller value. This is useful when you do not know the range that can be set.

Note that the current unit is always kept when you just use the **ENTER** after entering digits. For example, suppose that the Clock is currently set to 100.0 MS/s. When you press the **5**, **0** and **ENTER** buttons in this order, the Clock will be set to 50.0 MS/s. To set the Clock to 500 kS/s, press **0**, **.**, **5** and **ENTER** buttons, or **5**, **0**, **0**, **SHIFT**, and **8** buttons in this order.

Text Input

When you need to assign a name to a waveform file or equation, or a IP address to the instrument, the instrument displays a text dialog box. See in Figure 2-7. The text field is where you enter or change an existing character string. The character palette is where you select alphanumeric characters to insert into the text field. You can also select equation or file names from the name list to insert into the text field.

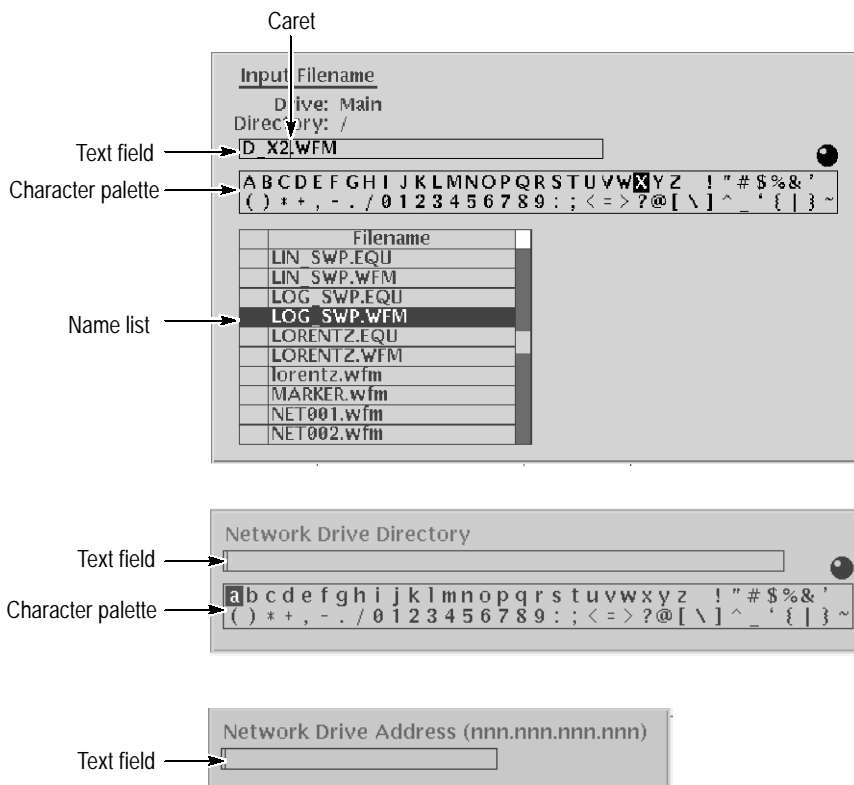

Figure 2-7: Three type of Input text dialog boxes

To select a character from the character palette, use the general purpose knob to highlight a character and then push the **ENTER** to insert the character into the text field. Repeat this step until you have entered all characters in the text field. By default, the character palette is selected. To select text from a file name list, use the \uparrow and \downarrow arrow buttons to move the knob icon to the file name list. Table 2-4 describes all the controls you can use for entering and editing text.

Table 2-4: Text input button functions

Control	Description
General purpose knob	Selects the character to insert into the text field.
\leftarrow and \rightarrow arrow buttons	Moves the character insertion caret left or right in the text field.
ENTER button	Inserts the selected character or character string into the text field.
\leftarrow button	Deletes one character to the left of the caret.
CLR button	Clears the entire text field.
Numeric buttons	Enters numeric characters into the text field.
SHIFT button	Enters a selected character in upper case. When you push the SHIFT button, the SHIFT LED lights. When the dialog box disappears, the SHIFT LED also goes off.

Shortcut Controls

Figure 2-8 shows the shortcut buttons and knobs that control specific instrument setup parameters. Using the shortcut controls lets you adjust the output setup parameters even while you are displaying another menu. Table 2-5 describes the shortcut controls.

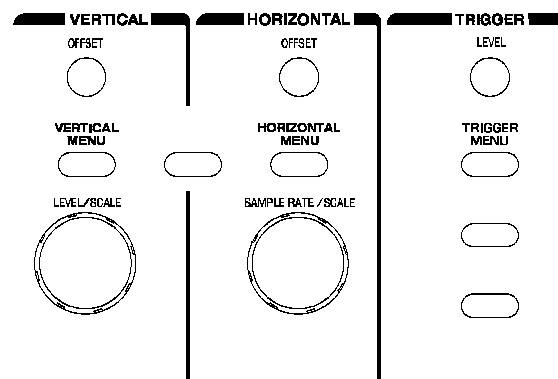

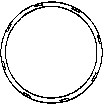

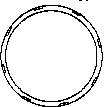



Figure 2-8: Shortcut controls

Table 2-5: Shortcut control descriptions

Controls	Description
VERTICAL	
	Displays the Vertical side menu. This is the same operation as selecting SETUP (front)! Vertical (bottom).
	Adjusts the vertical offset parameters. This is the same as selecting SETUP (front)! Vertical (bottom)! Offset (side), and then turning the general purpose knob.
	Adjusts the amplitude parameters. This is the same as selecting SETUP (front)! Vertical (bottom)! Amplitude (side), and then turning the general purpose knob.
HORIZONTAL	
	Displays the Horizontal side menu. This is the same as selecting SETUP (front)! Horizontal (bottom).
	Adjusts the clock setting. This is the same as selecting SETUP (front)! Horizontal (bottom)! Clock (side), and then turning the general purpose knob.
TRIGGER	
	Displays the Trigger side menu. This is the same as selecting SETUP (front)! Trigger (bottom).
	Adjusts the trigger level setting. This is the same as selecting SETUP (front)! Trigger (bottom)! Level (side), and then turning the general purpose knob.

File Management

This section is an overview of the instrument commands and operations for doing file management tasks. Refer to the *Reference:File Management* section in user manual.

File Type Extensions

The AWG610 Arbitrary Waveform Generator uses numerous file formats to hold different types of data. These file types are listed in Table 2-6. Note that the instrument checks the file format and processes the file based on its content, regardless of the file extension.

Table 2-6: AWG610 Waveform Generator file types

Extensions	Files	Description
.WFM	Waveform file	Contains waveform data. All signal data must be in waveform format before it can be output. Created with the waveform editor, by compiling an equation file, or when importing waveforms from external equipment.
.PAT	Pattern file	Contains pattern data. Created with the pattern editor.
.SEQ	Sequence file	Contains waveform sequence and trigger data. Created with the sequence editor.
.EQU	Equation file	Contains equations that describe a waveform. Created with the equation/text editor.
.TXT	Text file	Contains ASCII text. Created with the equation/text editor.
.SET	Setup file	Contains instrument setup and configuration data. Created from the SETUP menu.

Locating Files

There are three locations for storing waveform data on the AWG610 Waveform Generator. Data can be stored on the instrument hard disk drive, the instrument floppy disk drive, or a remote storage device accessible through the Ethernet interface. If the file you want to load is not on the current drive, use the EDIT menu main screen **Drive** and **Directory** bottom menu buttons to open side menus that let you change the current drive location. Table 2-7 describes the Drive and Directory bottom buttons.

Table 2-7: Drive and directory menus

Bottom menu	Side menu	Description
Drive	Main Floppy Net1 Net2 Net3	Changes the instrument current drive. To select a drive, push the appropriate side menu button. Note that there must be a floppy disk inserted in the instrument floppy disk drive in order to select the floppy drive. Note that the label Net1, Net2 and Net3 vary depending on the net name settings in the UTILITY menu.
Directory	Up Level Down Level Make Directory	Moves you up a directory level. Moves you down a directory level. To move down a directory level, select a directory name in the pop-up list and then push the Down Level side button. The filename list changes to show the contents of the directory. Creates a directory at the current level. To create a directory, push the Make Directory side button to display the Input New Directory Name dialog box. Enter the directory name in the name field, then push the OK side button. The instrument creates the new directory.

***NOTE.** In the following procedures, you may have to push the **EDIT** button twice to quit the editor. When the instrument does not display the file list, try to push the **EDIT** button again. If you are prompted, refer to Saving Files on page 2-20.*

Copying Files

Copying files is done from the **EDIT** menu screen. Do the following steps to copy a file:

- 1.** Push **EDIT** (front).

The instrument displays the file list.

- 2.** Select the file to copy.
- 3.** Push **File** (bottom)! **Copy** (side)
- 4.** Enter the new name for the copied file in the file name field
- 5.** Push **OK** (side).

The file is copied and renamed.

NOTE. You can copy a file or all files in another way. Refer to the *Operating Basics:* section in user manual for information.

You can also move a file or all files. Refer to the Operating Basics:Double Windows section of the user manual.

Renaming Files

Renaming files is done from the EDIT menu screen. Do the following steps to rename a file:

1. Push **EDIT** (front).

The instrument displays the file list.

2. Select the file to rename.
3. Push **File** (bottom)! **Rename** (side)
4. Enter the new name for the file in the file name field
5. Push **OK** (side).

The file is renamed.

Deleting Files

Deleting files is done from the EDIT menu screen. Do the following steps to delete a file:

1. Push **EDIT** (front). The instrument displays the file list.
2. Select the file to delete.
3. Push **File** (bottom)! **Delete** (side). The instrument displays a message box asking you to confirm deleting the file.
4. Push **OK** (side) to delete the file, or **Cancel** to cancel the operation and keep the file.

You can also delete all files on the current drive and directory by doing the following steps:

1. Push **EDIT** (front)! **File** (bottom)! **Delete All** (side).

The instrument displays a message box asking you to confirm deleting all files.

2. Push **OK** (side) to delete all files, or **Cancel** to cancel the operation and keep all files.

Read Only Attribute

You can change an attributes: read only or read/write on a file. Do the following steps to change the file attribute:

1. Push **EDIT** (front).
- The instrument displays the file list.
2. Select the file to change the attribute.
3. Push **File** (bottom)! **Attribute xxxx** (side).

The **xxxx** is **Read/Write** or **Read Only** that is the attribution of the selected file. Pushing this side button immediately changes the file attribute.

The file with a read only attribute is marked by , and the directory by . See Figure 2-9.

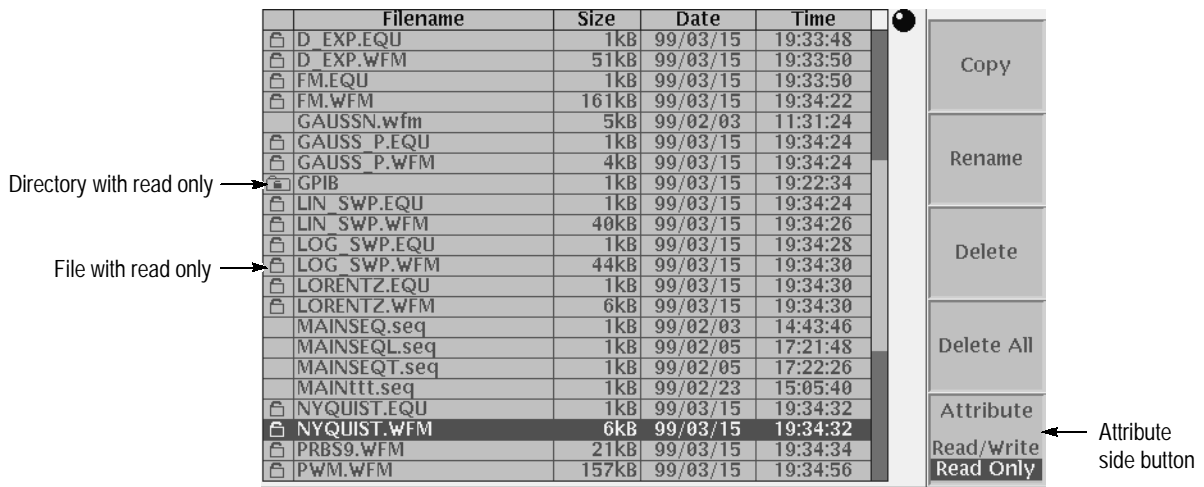

Figure 2-9: Files and directories with read only attribute

Saving Files

File saving is done from within each editor screen. You have the choice of saving your waveform data to the current file name or to a new file name. To save a waveform to its current file name, push **File** (bottom)! **Save** (pop-up)! **OK** (side).

If you are saving a waveform for the first time, the instrument opens the Input Filename dialog box, shown in Figure 2-10. Use this dialog box to enter a file name. If necessary, you can select a different storage media or directory by pushing the **Drive...** side menu button. When you are done entering the file name, push the **OK** side button or the **ENTER** front-panel button to close the dialog box and save the file.

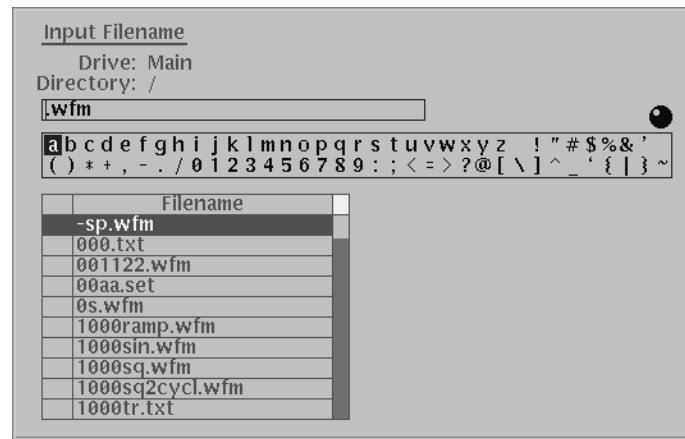

Figure 2-10: Input Filename dialog box

***NOTE.** When you exit an editor without saving edited data, the instrument displays the message **Save the changes you made?** Push the **Yes** side button to save the waveform data.*

To save waveform data to a new file name, push **File** (bottom)! **Save As** (pop-up)! **OK** (side). The instrument opens the Input Filename dialog box, shown in Figure 2-10. Use this dialog box to enter a file name. If necessary, you can select a storage media or directory by pushing the **Drive...** side menu button. When you are done entering the file name, push the **ENTER** front-panel button to close the dialog box and save the file.

If you are saving a file with a record length larger than 512 data points and the record is not evenly divisible by eight, the instrument needs to adjust the record length to meet internal memory record length requirements. The instrument displays one of the messages shown in Table 2-8. You can push the **OK** side button to accept the recommended change, or cancel the save and then edit the file to satisfy the data record length requirements.

Table 2-8: Waveform record length adjustment messages

Message	Description
Leave as it is	The data is saved, as it is, without making changes. The instrument will display an error message if you try to load a file that does not meet the instrument waveform constraints.
Append 0	With Level-0 data added after the data, a file with a data length meeting the requirements is created.
Expand	With the waveform data expanded, a file with a data length meeting the requirements is created.
Expand with Clock	With the waveform data expanded, a file with a data length meeting the requirements is created. In addition, the clock frequency increases without change in scaling factor. The settings are saved in the file.
Repeat	With repetitions of the original data linked, a file with a data length meeting the requirements is created. If the total length of the linked data exceeds 8.1M points, this will cause an error.

Signal Edit Process

This subsection describes the signal edit process.

Load the desired waveform data to be output into the waveform memory. New waveform data can be created using waveform editors incorporated in the AWG610 Waveform Generator. New data can also be created by combining the following:

- H A sample waveform data distributed with floppy disks.
- H Previously created waveform data on the built-in hard disk.
- H Waveform data measured or created by other equipment, which has been read through the network.

Waveform Data Structure

Each AWG610 Waveform Generator file may be for either an analog (extension .WFM) or digital pattern (extension .PAT). For analog waveform, the full scale of the DAC is represented as -1.0 to 1.0. This range is held with a resolution of 8 bits. The two pieces of marker information, as well as waveform data, are included.

Waveform Edit

To enable editing, the AWG610 Waveform Generator provides you with Waveform, Pattern, Sequence, Equation, and Text Editors. See Table 2-9 for the explanations of those editors.

Table 2-9: Editors

Editors	Descriptions
Waveform Editor	<p>The Waveform Editor lets you create or edit a waveform that is being displayed on the screen. It enables you to create any waveform by an operation such as cut and paste, partial inversion about the horizontal or vertical axis, shift, or scaling. This operation can be based on a standard waveform, such as a sine or rectangular wave, or the previously created waveform.</p> <p>The Waveform Editor also has a unique feature that is capable of editing a waveform with waveform calculation functions (absolute value of waveform, differentiation/integration, convolution, correlation, addition/subtraction/multiplication between waveforms and so on).</p>
Pattern Editor	<p>The Pattern Editor displays a digital signal pattern with a pattern data placed in 8-bit creation waveform memory; it creates a digital signal pattern according to the High/Low settings you made for the individual bits.</p> <p>In addition to the functions supported by the Waveform Editor, the Pattern Editor is capable of generating frequently used digital signals unique to digital signals and pseudo random patterns.</p>

Table 2-9: Editors (Cont.)

Editors	Descriptions
Sequence Editor	The Sequence Editor lets you create a more complex waveform by combining a few types of the waveform data that you have created using Waveform and/or Pattern Editors. This editor also enables a Waveform listing jump and output stop to take place. They follow the external event information from the EVENT IN connector as well as the number of repetitions and the order for the individual pieces of waveform data.
Text Editor	<p>The Text Editor creates an equation, more exactly, a waveform by a method of equations. When an equation has been created using this editor, you need to perform compiling.</p> <p>The Text Editor also enables you to edit a plain ASCII file. It should be used to edit ASCII-format waveform data created with another equipment as well as this instrument itself.</p>

Quick Edit The Quick Editor lets you modify and/or output any part of a waveform you are currently editing with the Waveform Editor. This is done in real time. The data between cursors can be scaled or shifted vertically and/or horizontally (Expand/Shift).



Theory of Operation

Theory of Operation

This section presents an overview of the AWG610 Arbitrary Waveform Generator hardware, data structures, and operating modes.

Interconnect Diagram

Figure 3-1 shows the AWG610 circuitry. This section describes the hardware blocks to provide the background knowledge necessary to use the instrument effectively.

CPU. The CPU controls the whole instrument using the GPIB interface, floppy disk connection, 10BASE-T Ethernet connection, user interface through the display screen and the front-panel, and so forth. See Figure 3-1.

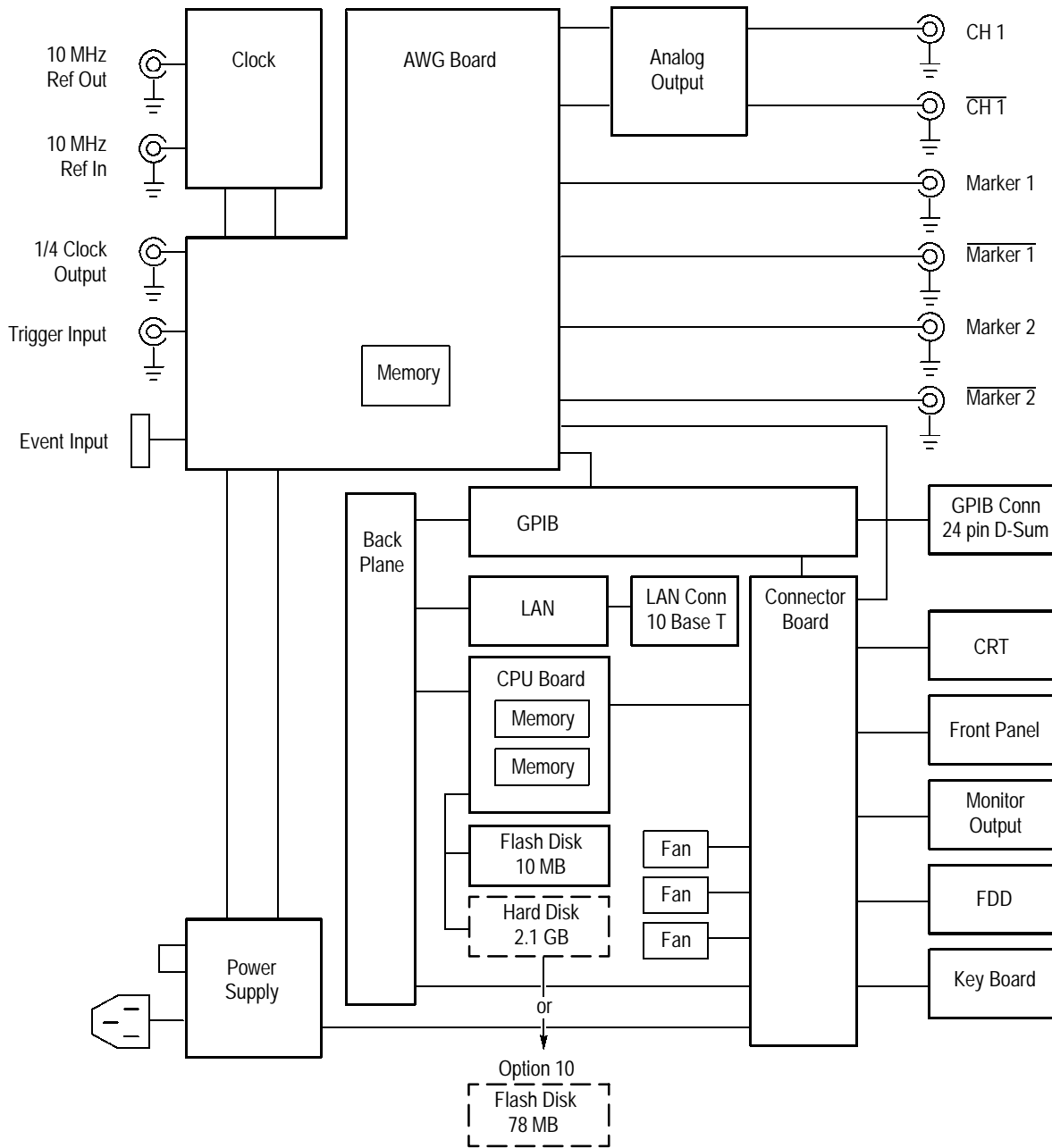

Figure 3-1: AWG610 interconnect diagram

Block Diagram

Figure 3-2 shows the main hardware blocks that make up the AWG610 Arbitrary Waveform Generator.

Clock Oscillator. You can select either the internal or external reference clock source by using the SETUP horizontal menu.

If you select the external source, the reference signal connected to the 10 MHz REF In connector on the rear panel will be used.

The internal clock is from the reference clock oscillator, which uses direct digital synthesis (DDS). Figure 3-2 shows the clock oscillator configuration.

Trigger Control. The Trigger Control block controls the Memory Address Control in the operation mode that you specified from the RUN MODE menu.

Waveform Memory and Shift Register. The Waveform Memory block has 8 bits for waveform data and 2 bits per channel for markers, thus a total length of 8.1 M points. You can set any value from 512 points to 8.1 M points for the length of waveform data. It must be in increments of 8.

The Shift Register block is used to provide waveform data from the DAC at a rate up to 2.6 GS/s.

RUN modes. Selecting a RUN mode from the SETUP menu causes one of the following to operate the AWG610 Arbitrary Waveform Generator:

Table 3-1: Run modes

Modes	Descriptions
Continuous	Consecutively output regardless of existence of a trigger signal.
Triggered	The output signal is obtained only once when one of the following is input: <ul style="list-style-type: none"> H An external trigger signal from the rear panel's TRIG IN connector. H A trigger signal generated with the front-panel's FORCE TRIGGER button. H A trigger command from external controller. H If the SEQUENCE has been defined, the TRIGGERED output is obtained only once according to the definition.
Gated	The waveform is output only while: <ul style="list-style-type: none"> H An external trigger signal from the rear panel's TRIG IN connector. H A gate signal through the front-panel's FORCE TRIGGER button is TRUE.
Enhanced	The waveform is obtained, in the order defined with the sequence, based on: <ul style="list-style-type: none"> H A trigger signal (for example, an external trigger signal from the rear panel's TRIG IN connector). H An event signal from the rear panel's EVENT IN connector. H An event signal from the front panel's FORCE TRIGGER button. H An event signal from the front panel's FORCE EVENT button (logic jump only).

Analog Circuit. The Analog Circuit block contains the Filter, Attenuator, Output Amplifier, and Offset Circuits. These circuits are used to process signals generated from the DAC.

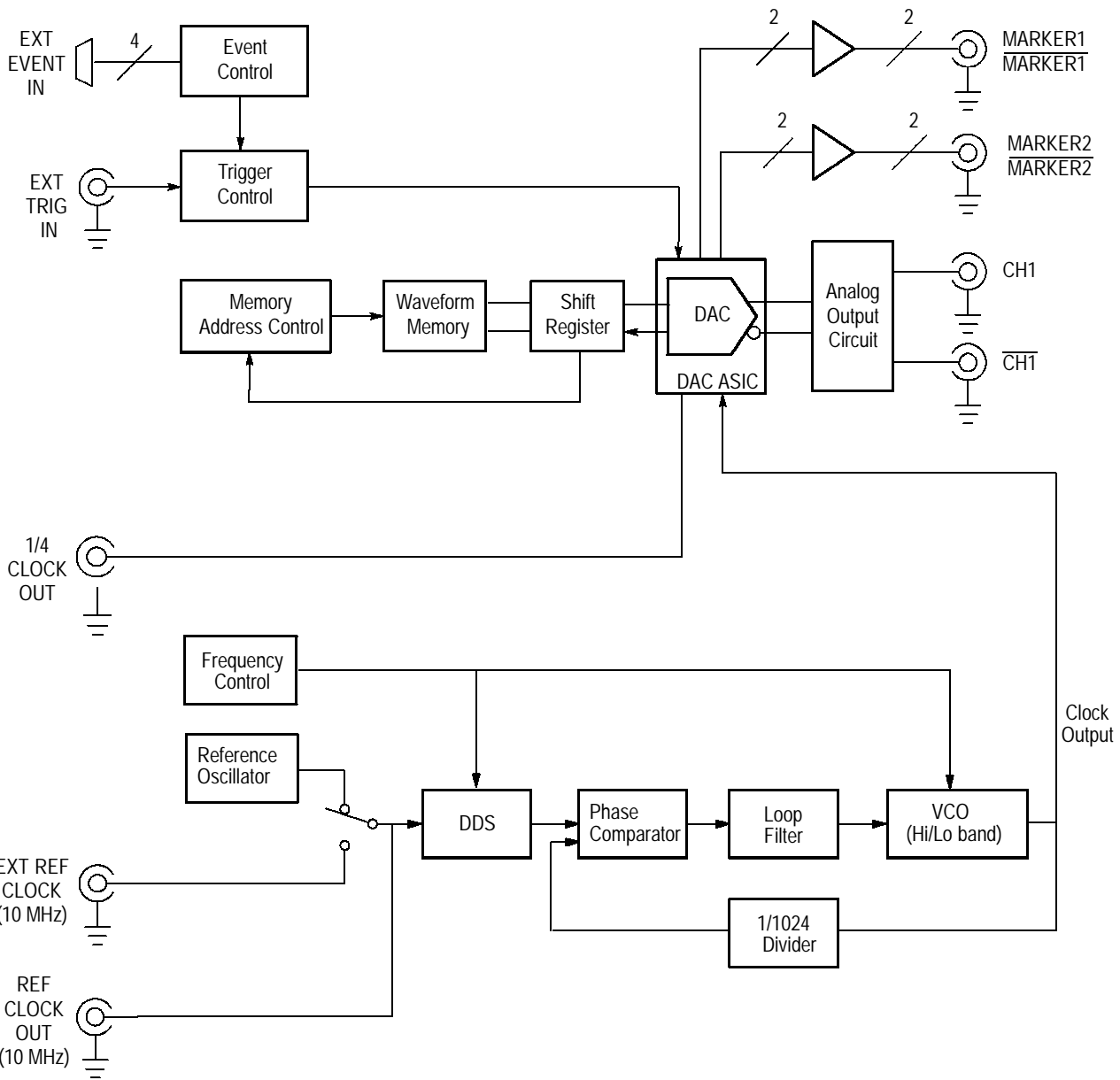

Figure 3-2: AWG610 block diagram

Memory Address Control. The Memory Address Control controls the addresses used to read waveform memory data.

This block loads the first address of the waveform into the Address Counter that was loaded into the waveform memory. It loads the waveform data length to the Length Counter. The Address Counter specifies the point from which the waveform was generated, and the Length Counter waveform ending position.

The Address and Length Counters operate with clocks produced by quarter frequency-division for the clocks from the clock oscillator.

If the repeat count value has been loaded in the Repeat Counter, the waveform is generated the specified number of times.

This block controls the sequence to the event signals generated in Enhanced Mode.

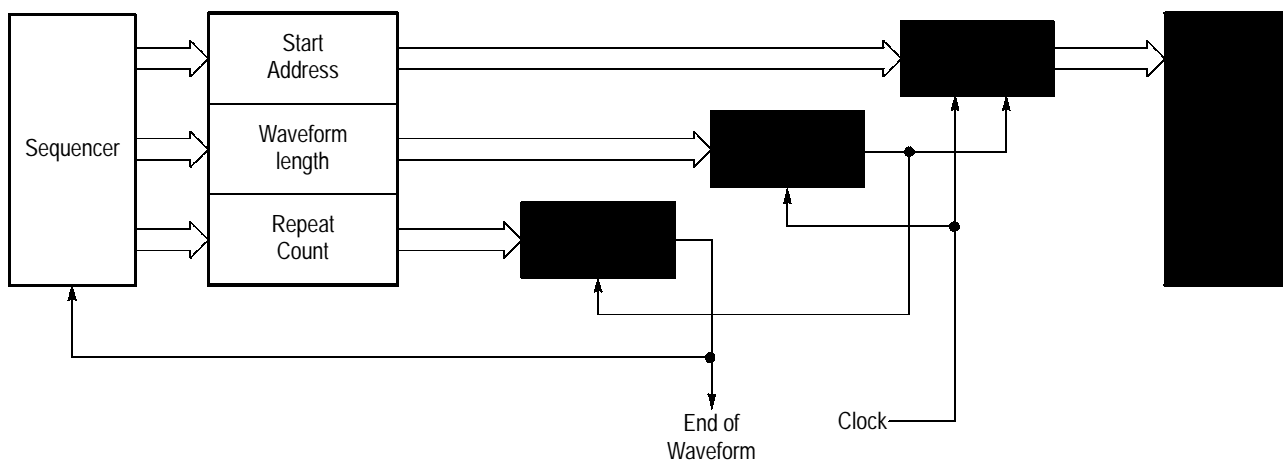

Figure 3-3: Relationship between memory address control and waveform memory

Figure 3-3 shows the relationship between the memory address control and the waveform memory.



Performance Verification

Performance Verification

Two types of Performance Verification procedures can be performed on this product: *Self Tests* and *Performance Tests*. You may not need to perform all of these procedures, depending on what you want to accomplish.

- H Verify that the AWG610 Arbitrary Waveform Generator is operating correctly by running the self tests which begin on page 4-3.

Advantages: These procedures require minimal time to perform, require no additional equipment, and test the internal hardware of the AWG610 Arbitrary Waveform Generator.

- H If a more extensive confirmation of performance is desired, complete the self test, and then do the performance test beginning on page 4-7.

Advantages: These procedures add direct checking of warranted specifications. They require more time to perform and suitable test equipment is required. (Refer to *Equipment Required* on page 4-8).

Conventions

Throughout these procedures the following conventions apply:

- H Each test procedure uses the following general format:

Title of Test

Equipment Required

Prerequisites

Procedure

- H Each procedure consists of as many steps, substeps, and subparts as required to do the test. Steps, substeps, and subparts are sequenced as follows:

1. First Step

- a. First Substep

- H First Subpart

- H Second Subpart

- b. Second Substep

2. Second Step

- H Instructions for menu selection use the following format: **front-panel BUTTON! Main Menu Button! Side Menu Button**. For example, Push **UTILITY! System! Reset to Factory! OK**
- H The name of the button or knob appears in boldface type:

Push **EDIT**; then **Drive...**, push **Floppy** side button and use the knob to select SINE.WFM from the file list.

Self Tests

The *Self Tests* use internal routines to confirm basic functionality and proper adjustment. No test equipment is required to do these test procedures.

The self tests include internal diagnostics to verify that the instrument passes the internal circuit tests, and calibration routines to check and adjust the instrument internal calibration constants.

Diagnostics

This procedure uses internal routines to verify that the instrument is operating correctly. No test equipment or hookups are required.

The instrument automatically performs the internal diagnostics when powered on; you can also run the internal diagnostics using the menu selections described in this procedure. The difference between these two methods of initiating the diagnostics is that the menu method does a more detailed memory check than the power-on method.

Equipment required	None
Prerequisites	Power on the instrument and allow a twenty-minute warmup period before doing this procedure.

Confirm that there is no output being performed by verifying that the RUN LED is not on. If the LED is on, push the **RUN** button to turn it off.

Do the following to verify that the instrument passes the internal circuit tests:

Push **UTILITY** (front-panel)! **Diag** (bottom)! **Diagnostic All** (side).

The diagnostic menu is displayed and all tests are selected. Refer to Figure 4-1. If All is not displayed, select All using the general purpose knob.

The list on the screen shows the test items and results in the calibration and diagnostics previously made. Select all of the test items shown on the screen or use the general purpose knob to select a single test item that you want to run. The result of the diagnostics are shown as error code. Pass means that the tests have been made without error. If an error is detected, an error code is displayed.

You can also specify how many times the diagnostic tests are performed. Push the **Cycle** side button and then turn the general purpose knob to select the cycle from 1, 3, 10, 100 or Infinite. When you select Infinite, the tests are repeatedly performed, and are not be terminated until you push the Abort Diagnostic side button.

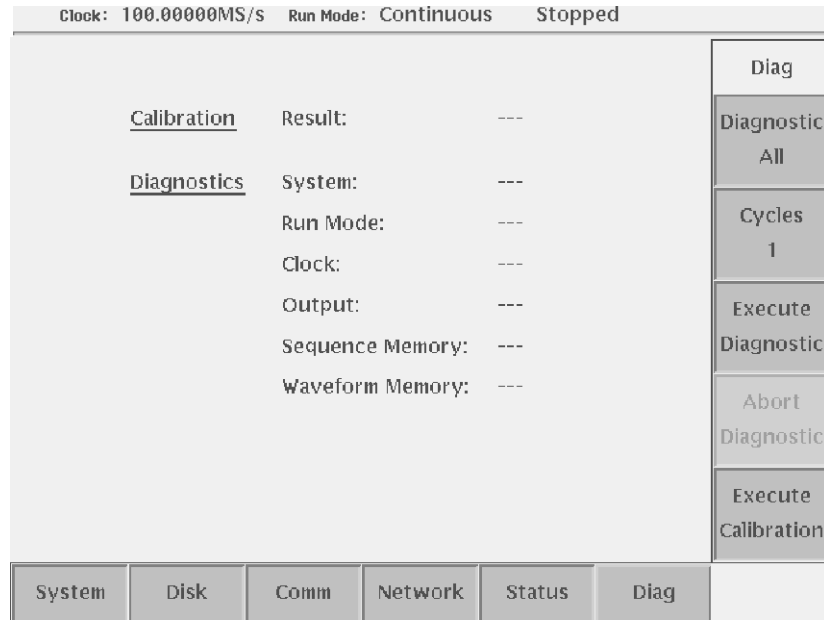

Figure 4-1: Diagnostic menu

Do the following to execute all of the AWG610 Arbitrary Waveform Generator diagnostics automatically:

Push the **Execute Diagnostic** side button.

The internal diagnostics do an extensive verification of AWG610 Arbitrary Waveform Generator functions. While this verification progresses, the screen displays the clock icon. When finished, the resulting status appears on the screen.

Verify that no failures are found and reported on-screen. If the diagnostics terminates without error, Pass is displayed instead of the - - -. If a value is displayed, meaning an error is detected, consult a qualified service technician for further assistance.

Push any bottom or menu button (other than UTILITY) to exit the diagnostic screen.

Calibration

The instrument includes internal calibration routines that check electrical characteristics such as offset, attenuations and filters. Perform calibration to adjust internal calibration constants as necessary. This procedure describes how to do the internal calibration.

Equipment required	None
Prerequisites	Power on the instrument and allow a 20 minute warmup period at an ambient temperature between +20_ C and +30_ C before doing this procedure.

Confirm that there is no output being performed by verifying that the RUN LED is not on. If the LED is on, push the **RUN** button to turn it off.

***NOTE.** Some calibration items may fail if you start calibration while output is being performed.*

Do the following steps to verify that the internal adjustments have passed:

1. Push **UTILITY** (front-panel)! **Diag** (bottom)! **Execute Calibration** (side).

This executes the AWG610 Arbitrary Waveform Generator calibration routines automatically.

The internal calibration does an extensive verification of proper AWG610 Arbitrary Waveform Generator functions. While this verification progresses, the message box displaying *Executing Calibration* appear on screen. When finished, the resulting status will appear in the message box as shown in Figure 4-2.

<u>CALIBRATION RESULTS</u>		
	CH1	CH2
Output Offset:	Pass	Pass
Internal Offset:	Pass	Pass
Gain:	Pass	Pass
Attenuator 3db:	Pass	Pass
6db:	Pass	Pass
12db:	Pass	Pass
20db:	Pass	Pass
Filter 200MHz:	Pass	Pass
100MHz:	Pass	Pass
50MHz:	Pass	Pass
20MHz:	Pass	Pass

Figure 4-2: Calibration result message box

Verify that no failures are found and reported in the message box. If the calibration displays Fail as the result, consult a qualified service technician for further assistance.

2. Push the **OK** side button and then any bottom or menu button (other than the **UTILITY**) to exit the dialog screen.

NOTE. The calibration data in the memory may be lost if the instrument is powered off while the calibration is executed.

Performance Tests

This section contains a collection of procedures for checking that the AWG610 Arbitrary Waveform Generator performs as warranted.

The procedures are arranged in thirteen logical groupings, presented in the following order:

Table 4-1: Performance test items

Titles	Test items	See (specifications)
Operating mode tests	Continuous, Triggered, and Gated mode normality	Page 1-6
Amplitude and offset accuracy tests (normal out)	Amplitude accuracy, and DC offset accuracy	Page 1-7
Amplitude, DC offset and rise time accuracy tests (direct DA out)	Amplitude accuracy, DC offset accuracy and Rise time accuracy	Page 1-8
Pulse response tests (normal out)	Rise time accuracy, Aberration, and Flatness	Page 1-8
Sine wave tests	Harmonics level accuracy, and Noise level accuracy	Page 1-8
Internal trigger tests	Trigger interval normality	Page 1-7
Trigger input tests	Trigger level accuracy, and Trigger function normality	Page 1-11
Event input and enhanced mode tests	External event input function normality, and Event mode normality	Page 1-12
1/4 Clock frequency and 10 MHz reference input tests	1/4 clock output frequency and Reference input normality accuracy	Page 1-7
1/4 Clock output level tests	Clock output normality	Page 1-10
10 MHz Reference output level tests	10 MHz Reference Clock output normally	Page 1-10
Marker output tests	Marker output level accuracy	Page 1-10
Marker delay tests	Marker delay function	

The performance tests check all of the characteristics that are designated as checked in *Appendix A: Specifications*. (The characteristic items that must be checked are listed with the check mark (✓) in *Appendix A: Specifications*).

NOTE. *These procedures extend the confidence level provided by the basic procedures described on page 4-3. The basic procedures should be done first, and then these procedures performed if desired.*

Prerequisites The tests in this section comprise an extensive, valid confirmation of performance and functionality when the following requirements are met:

- H The cabinet must be installed on the instrument.
- H You must have performed and passed the procedures under *Self Tests*, found on page 4-3.
- H The waveform generator must have been recently adjusted at an ambient temperature between +20_ C and +30_ C, must have been operating for a warm-up period of at least 20 minutes, and must be operating at an ambient temperature between +10_ C and +40_ C.

Refer to *Conventions* on page 4-1 for more information.

Equipment Required These procedures use external, traceable signal sources to directly check warranted characteristics. Table 4-2 lists the required equipment used to complete the performance tests.

Table 4-2: Test equipments

Item number and description	Minimum requirements	Example (recommended)	Purpose
1. Frequency Counter	1 MHz to 100 MHz, Accuracy: < 0.2 ppm	Anritsu MF1603A	Used to check reference input test.
2. Digital multi meter	DC volts range: 0.05 V to 10 V, Accuracy: ± 0.1 %	Fluke 8842A	Used to check to measure voltage.
3. Oscilloscope	Bandwidth: > 500 MHz, 1 MΩ and 50 Ω inputs	Tektronix TDS784D	Checks output signals. Used in many procedures.
4. Oscilloscope	Bandwidth: > 6 GHz, Rise time: > 58.3 ps, 50 Ω input	Tektronix TDS820	Checks direct DA rise time.
5. Spectrum Analyzer	1 kHz to 1 GHz	Tektronix 497P or Advantest R4131	Checks output signals.
6. Function Generator	Output voltage: -5 V to +5 V, Frequency accuracy: < 0.01 %	Tektronix AFG2020	Generates external input signals. Used in many input signal test procedures.
7. Programmable Voltage Source	Output voltage: -5 V to +5 V, Voltage accuracy: < 1 %, Output current: > 10 mA	Data Precision 8200	Used to check trigger input.
8. SMA Coaxial Cable (2 required)	50 Ω, male to male SMA connectors	Tektronix part number 174-1427-00	Signal interconnection
9. BNC Coaxial Cable (2 required)	50 Ω, male to male BNC connectors	Tektronix part number 012-0482-00	Signal interconnection
10. Adapter (2 required)	SMA (male) to BNC (female), 50 Ω	Tektronix part number 015-0554-00	Signal interconnection

Table 4-2: Test equipments (cont.)

Item number and description	Minimum requirements	Example (recommended)	Purpose
11. Adapter	SMA (female) to BNC (male), 50 Ω	Tektronix part number 015-0572-00	Signal interconnection
12. Adapter	BNC (female) to N (male)	Tektronix part number 103-0045-00	Signal interconnection
13. BNC-T Connector	BNC (male) to BNC (female) to BNC (female)	Tektronix part number 103-0030-00	Signal interconnection
14. Dual-Banana Connector	BNC (female) to dual banana	Tektronix part number 103-0090-00	Signal interconnection
15. DC block	N type, 50 Ω	Tektronix part number 015-0509-00	DC block
16. SMA Terminator (2 required)	50 Ω, SMA male	Tektronix part number 015-1022-00	Signal termination
17. Precision Terminator	50 Ω, 0.1 %, BNC	Tektronix part number 011-0129-00	Signal termination
18. Performance check disk	Must use example listed	Supplied with the product, Tektronix part number 063-3218-00	Used to provide waveform files
19. Ground closure (loop-back cable) with 9-pin, D-type connector		Custom, See Figure 4-3.	Used for event mode test

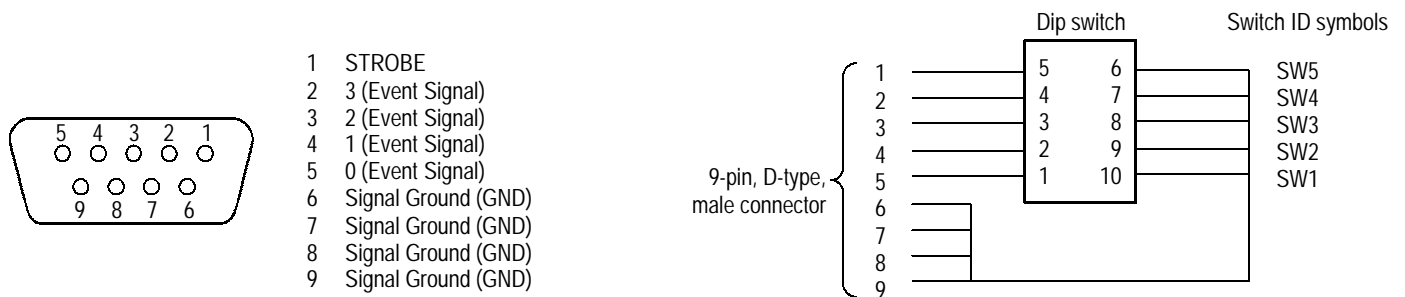

Figure 4-3: EVENT IN connector pins and signals and ground closure connector

Loading Files

The following steps explain how to load files from the Performance Check/Adjustment disk into waveform memory and/or sequence memory.

1. Insert the disk into the AWG610 Arbitrary Waveform Generator floppy disk drive.
2. Select **SETUP** (front)! **Waveform/Sequence** (bottom)! **Load...** (side)! **Drive...** (side).

The Select Drive dialog box appears as show in Figure 4-4.

3. Select Floppy from the dialog box with the general purpose knob, and then push the **OK** side button.

The Select Drive dialog box disappears, and the files in the floppy disk are listed on the Select File dialog box.

4. Use the general purpose knob to select a file to be loaded from the dialog box, and then push the **OK** side button.

The waveform or sequence you selected is loaded into the instrument, and the instrument is also setup with the parameters stored in that file.

5. Remove the floppy disk from the floppy drive if the floppy disk is no longer needed.

6. Push any bottom button or menu button to exit the menu.

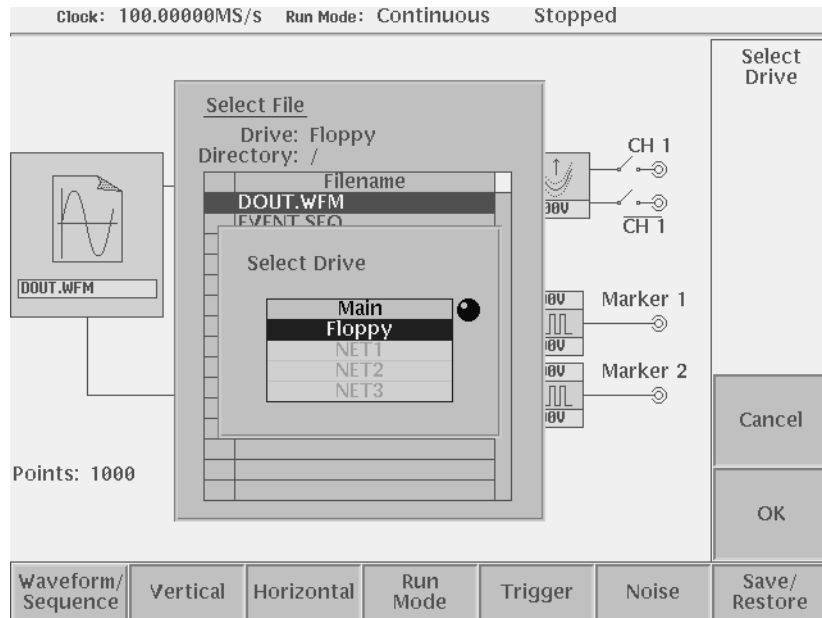

Figure 4-4: Loading file; selecting storage drive

NOTE. The floppy disk file list displayed on the screen does not automatically update when you replace the diskette with another diskette. To update the file list, re-select the floppy disk drive.

Performance Check/Adjustment Files

Table 4-3 lists the sequence and waveform files on the Performance Check/Adjustment disk that are used in these performance tests, the AWG610 Arbitrary Waveform Generator front-panel settings that each file sets up, and the performance test that uses each file.

NOTE. The files on the Performance Check disk are locked (the files are marked by the icon  in the file list), so the data in these files cannot be changed unless the lock is opened.

Table 4-3: Waveforms and sequences in performance check disk

No.	File name	EDIT menu		SETUP menu				Marker setup	Usage
		Form	Points	Clock	Filter	Ampl	Offset		
1	MODE.WFM		1000	2.6 GHz	Through	1 V	0 V	Marker1,2: 0 to 499: High, 500 to 999: Low	Run mode, Trigger level, Marker
2	PULSE.WFM		1000	100 MHz	Through	1 V	0 V		Pulse amplitude, Internal trigger accuracy
3	SINE.WFM		512	2.6 GHz	Through	1 V	0 V		Sine characteristics
4	AMP1.SEQ								Amplitude accuracy (Normal out)
5	AMP2.SEQ								Amplitude accuracy (Direct out)
6	DC_P.WFM (AMPx.SEQ) ¹		1000	100 MHz	Through	1 V	0 V		Amplitude accuracy
7	DC_M.WFM (AMPx.SEQ) ¹		1000	100 MHz	Through	1 V	0 V		Amplitude accuracy
8	DC0.WFM (AMP2.SEQ)		1000	100 MHz	Through	1 V	0 V		Amplitude accuracy

Table 4-3: Waveforms and sequences in performance check disk (cont.)

No.	File name	EDIT menu		SETUP menu				Marker setup	Usage
		Form	Points	Clock	Filter	Ampl	Offset		
9	OFFSET.WFM		1000	100 MHz	Through	20 mV	0 V		Offset accuracy
10	TRIG.WFM		1000	1 MHz	Through	1 V	0 V		Trigger input
11	PT_EVENT.SEQ								Event input
12	PT_STROB.SEQ								Event input
13	S520.WFM (PT_XXXXX.SEQ) ²		520	200 MHz	Through	1 V	0 V		Event input
14	S520H.WFM (PT_XXXXX.SEQ) ²		520	200 MHz	Through	1 V	0 V		Event input
15	R520H.WFM (PT_XXXXX.SEQ) ²		520	200 MHz	Through	1 V	0 V		Event input
16	T520H.WFM (PT_XXXXX.SEQ) ²		520	200 MHz	Through	1 V	0 V		Event input
17	Q520H.WFM (PT_XXXXX.SEQ) ²		520	200 MHz	Through	1 V	0 V		Event input
18	NULL520H.WFM (PT_XXXXX.SEQ) ²		520	200 MHz	Through	1 V	0 V		Event input

¹ The AMPx.SEQ represents AMP1.SEQ and AMP2.SEQ.

² The PT_XXXXX.SEQ represents PT_EVENT.SEQ and PT_STROB.SEQ

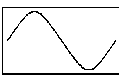
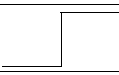
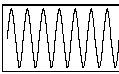
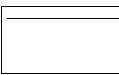
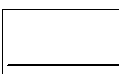
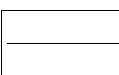
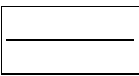
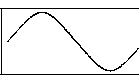
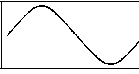
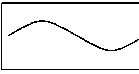
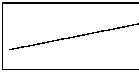
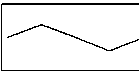
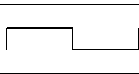
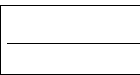
AWG610 Test Record

Photocopy this test record and use to record the performance test results for your AWG610.

AWG610 Test Record

Instrument Serial Number: _____		Certificate Number: _____		
Temperature: _____		RH %: _____		
Date of Calibration: _____		Technician: _____		
AWG610 Performance Test	Minimum	Incoming	Outgoing	Maximum
Operating Mode				
Check Cont Mode	Pass/Fail	_____	_____	Pass/Fail
Check Triggered Mode (when the FORCE TRIGGER button is pushed)	Pass/Fail	_____	_____	Pass/Fail
Check Triggered Mode (with external triggering)	Pass/Fail	_____	_____	Pass/Fail
Check Gated Mode (when the FORCE TRIGGER button is pushed)	Pass/Fail	_____	_____	Pass/Fail
Check Gated Mode (with the gate signal when the AWG trigger polarity is set to positive)	Pass/Fail	_____	_____	Pass/Fail
Check Gated Mode (with the gate signal when the AWG trigger polarity is set to negative)	Pass/Fail	_____	_____	Pass/Fail
Amplitude and Offset Accuracy (Normal Out)				
CH1 Amplitude	20 mV	17.70 mV	_____	22.30 mV
	200 mV	195.0 mV	_____	205.0 mV
	2 V	1.9680 V	_____	2.0320 V
CH1 Amplitude	20 mV	17.70 mV	_____	22.30 mV
	200 mV	195.0 mV	_____	205.0 mV
	2 V	1.9680 V	_____	2.0320 V
CH1 Offset	0 V	- 10.0 mV	_____	+ 10.0 mV
	+1 V	+ 0.980 V	_____	+ 1.020 V
	-1 V	- 0.980 V	_____	- 1.020 V
CH1 Offset	0 V	- 10.0 mV	_____	+ 10.0 mV
	+1 V	+ 0.980 V	_____	+ 1.020 V
	-1 V	- 0.980 V	_____	- 1.020 V

Performance Verification

AWG610 Test Record (cont.)

Instrument Serial Number: _____ Certificate Number: _____
 Temperature: _____ RH %: _____
 Date of Calibration: _____ Technician: _____

AWG610 Performance Test		Minimum	Incoming	Outgoing	Maximum
Amplitude, Offset Accuracy and Rise Time (Direct DA Out)					
CH1 Amplitude	20 mV 1 V	17.60 mV 0.9780 V	_____	_____	22.40 mV 1.0220 V
$\overline{\text{CH1}}$ Amplitude	20 mV 1 V	17.60 mV 0.9780 V	_____	_____	22.40 mV 1.0220 V
CH1 Offset	0 V	- 10.0 mV	_____	_____	+ 10.0 mV
$\overline{\text{CH1}}$ Offset	0 V	- 10.0 mV	_____	_____	+ 10.0 mV
CH1 Rise Time	0.5 V Amplitude	N/A	_____	_____	400 ps
$\overline{\text{CH1}}$ Rise Time	0.5 V Amplitude	N/A	_____	_____	400 ps
Pulse Response					
CH1 Rise Time	1 V Amplitude (10 to 90 % point)	N/A	_____	_____	750 ps
CH1 Aberration	1 V Amplitude	- 10.0 %	_____	_____	+ 10.0 %
CH1 Flatness	1 V Amplitude (after 20 ns from rising edge)	- 3.0 %	_____	_____	+ 3.0 %
$\overline{\text{CH1}}$ Rise Time	1 V Amplitude (10 to 90 % point)	N/A	_____	_____	750 ps
$\overline{\text{CH1}}$ Aberration	1 V Amplitude	- 10.0 %	_____	_____	+ 10.0 %
$\overline{\text{CH1}}$ Flatness	1 V Amplitude (after 20 ns from rising edge)	- 3.0 %	_____	_____	+ 3.0 %
Sine Wave					
Harmonic Level (DC to 800 MHz)		N/A	_____	_____	40 dBc
Noise Level (DC to 800 MHz)		N/A	_____	_____	50 dBc
Internal Trigger					
Internal Trigger function (at the trigger interval to 1 ms)		Pass/Fail	_____	_____	Pass/Fail
Internal Trigger function (at the trigger interval to 2 ms)		Pass/Fail	_____	_____	Pass/Fail

AWG610 Test Record (cont.)

Instrument Serial Number: _____ Certificate Number: _____
 Temperature: _____ RH %: _____
 Date of Calibration: _____ Technician: _____

AWG610 Performance Test	Minimum	Incoming	Outgoing	Maximum
Trigger Input				
Positive Threshold (set the triggering level to 5 V) No trigger when input voltage vary from 0 V to 4.65 V.	Pass/Fail	_____	_____	Pass/Fail
Trigger when input voltage vary from 4.65 V to 5.35 V.	Pass/Fail	_____	_____	Pass/Fail
Negative Threshold (set the triggering level to -5 V) No trigger when input voltage vary from 0 V to -4.65 V.	Pass/Fail	_____	_____	Pass/Fail
Trigger when input voltage vary from -5.35 V to -4.65 V.	Pass/Fail	_____	_____	Pass/Fail
Event Input and Enhanced Mode				
Check Event Input with Strobe Off pin 0 (when SW1 of the ground closure is closed)	Pass/Fail	_____	_____	Pass/Fail
pin 1 (when SW2 of the ground closure is closed)	Pass/Fail	_____	_____	Pass/Fail
pin 2 (when SW3 of the ground closure is closed)	Pass/Fail	_____	_____	Pass/Fail
pin 3 (when SW4 of the ground closure is closed)	Pass/Fail	_____	_____	Pass/Fail
Check Strobe Input (when SW5 of the ground closure is on and off)	Pass/Fail	_____	_____	Pass/Fail
1/4 Clock Frequency and 10 MHz Reference Input				
Check 1/4 Clock Out Frequency Internal Clock = 200 mH	49 999 950 Hz	_____	_____	50 000 050 Hz
Check output with 10 MHz Reference Input 10 mH Ref In = 10 mH	49 990 000 Hz	_____	_____	50 010 000 Hz
Check output with 10.1 MHz Reference Input 10 mH Ref In = 10.1 mH	50 490 000 Hz	_____	_____	50 510 000 Hz
1/4 Clock Output Level				
Check 1/4 Clock Amplitude (Larger than 0.50 V)	Pass/Fail	_____	_____	Pass/Fail
10 MHz Reference Output Level				
Check 1/4 Clock Amplitude	≥ 1.00 V	_____	_____	N/A

Performance Verification

AWG610 Test Record (cont.)

Instrument Serial Number: _____ Certificate Number: _____
 Temperature: _____ RH %: _____
 Date of Calibration: _____ Technician: _____

AWG610 Performance Test	Minimum	Incoming	Outgoing	Maximum
Marker Output				
MARKER1 Low level (Set the level to -1.1 V.)	-1.2550 V	_____	_____	-0.9450 V
MARKER1 High level (Set the level to 3.0 V.)	2.750 V	_____	_____	3.250 V
MARKER1 Low level (Set the level to -1.1 V.)	-1.2550 V	_____	_____	-0.9450 V
MARKER1 High level (Set the level to 3.0 V.)	2.750 V	_____	_____	3.250 V
MARKER2 Low level (Set the level to -1.1 V.)	-1.2550 V	_____	_____	-0.9450 V
MARKER2 High level (Set the level to 3.0 V.)	2.750 V	_____	_____	3.250 V
MARKER2 Low level (Set the level to -1.1 V.)	-1.2550 V	_____	_____	-0.9450 V
MARKER2 High level (Set the level to 3.0 V.)	2.750 V	_____	_____	3.250 V
Marker Delay				
Marker 1 Delay Range (0 ns to 1.5 ns)	Pass/Fail	_____	_____	Pass/Fail
Marker 1 Delay (when set to 1.5 ns delay)	1.050 ns	_____	_____	1.650 ns
Marker 2 Delay Range (0 ns to 1.5 ns)	Pass/Fail	_____	_____	Pass/Fail
Marker 2 Delay (when set to 1.5 ns delay)	1.050 ns	_____	_____	1.650 ns

Operating Mode Tests

The following procedures verify the operation of the Cont, Triggered and Gated modes.

NOTE. When you output signal from the CH1 or $\overline{CH1}$ OUTPUT, check that the other OUTPUT ($\overline{CH1}$ or CH1) LED is off. If the other OUTPUT LED is on, push the $\overline{CH1}$ or CH1 OUT button to turn off the output.

Check Cont Mode

Equipment required	A 50 Ω SMA coaxial cable, a SMA(Fe)-BNC(Ma) adapter and an oscilloscope (TDS700).
Prerequisites	The AWG Arbitrary Waveform Generator must meet the prerequisites listed on page 4-8.

Do the following steps to install the test hookup and set the test equipment controls:

1. Use a 50 Ω coaxial cable to connect the AWG610 Arbitrary Waveform Generator CH1 output connector to the oscilloscope CH1 input connector (see Figure 4-5).

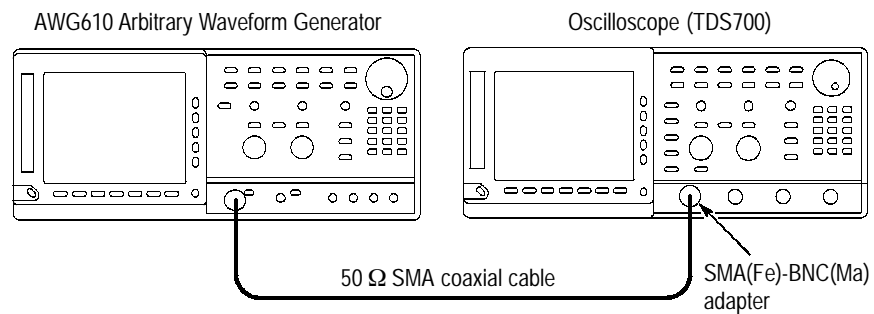

Figure 4-5: Cont mode initial test hookup

2. Set the oscilloscope controls as follows:

Vertical	CH1
CH1 coupling	DC
CH1 scale	0.2 V/div
CH1 input impedance	50 Ω
Horizontal	
Sweep	200 ns/div
Trigger	

Source CH1
 Coupling DC
 Slope Positive
 Level +100 mV
 Mode Auto

Do the following steps to set the AWG610 Arbitrary Waveform Generator controls and to select the waveform file:

1. Push **UTILITY** (front-panel)! **System** (bottom)! **Factory Reset** (side)! **OK** (side).

2. Load the MODE.WFM file.

Refer to *Loading Files* on page 4-10 for file loading procedures.

3. Push the **RUN** and **CH1** output buttons.

The LEDs above the RUN button and CH1 output connectors are on.

4. Check that the amplitude of the sine wave displayed on the oscilloscope is 5 vertical divisions and that a waveform of approximately one cycle per 1.9 horizontal divisions is displayed.

Check Triggered Mode

The following table lists the equipment and prerequisites required to check the Triggered mode.

Equipment required	Two 50 Ω BNC coaxial cables, a 50 Ω SMA coaxial cable, a SMA(Fe)-BNC(Ma) adapter, a BNC-T (male to 2 females) adapter , a function generator, and an oscilloscope (TDS700).
Prerequisites	The AWG610 Arbitrary Waveform Generator must meet the prerequisites listed on page 4-8.

Do the following steps to install the test hookup and set the test equipment controls:

1. Use a 50 Ω BNC coaxial cable and a BNC-T adapter to connect the function generator output connector to the AWG610 Arbitrary Waveform Generator TRIG IN connector. Refer to Figure 4-6.

2. Connect a second 50 Ω BNC coaxial cable to the BNC-T adapter. Connect the opposite end of the coaxial cable to the oscilloscope CH2 input.

3. Use a 50 Ω SMA coaxial cable and SMA(Fe)-BNC(Ma) adapter to connect the AWG610 Arbitrary Waveform Generator CH1 output connector to the oscilloscope CH1 input connector.

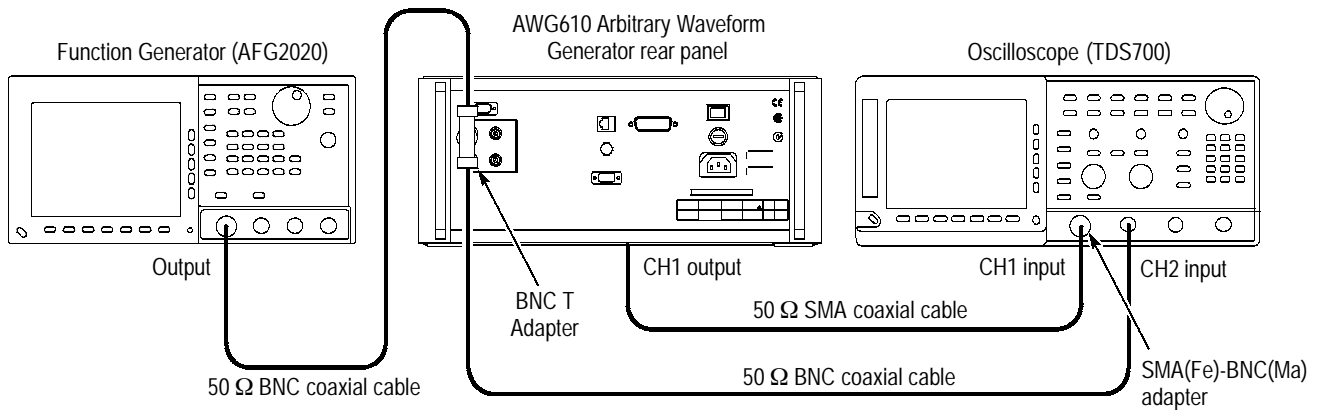

Figure 4-6: Triggered mode initial test hookup

4. Set the oscilloscope controls as follows:

Vertical	CH1 and CH2
CH1 coupling	DC
CH1 scale	0.5 V/div
CH2 scale	2 V/div
CH1 input impedance	50 Ω
CH2 input impedance	1 MΩ
Horizontal	
Sweep	200 ns/div
Trigger	
Source	CH1
Coupling	DC
Slope	Positive
Level	+100 mV
Mode	NORMAL

5. Set the function generator (AFG2020) controls as follows:

Function	Square
Mode	Continuous
Parameters	
Frequency	900 kHz
Amplitude	2.0 V into 50 Ω (4.0 V into 1 M Ω)
Offset	1.0 V into 50 Ω (2.0 V into 1 M Ω)
Output	Off

6. Follow the substeps below to set the AWG610 Arbitrary Waveform Generator controls and to select the waveform file:

- a. Push **UTILITY** (front-panel)! **System** (bottom)! **Factory Reset** (side)! **OK** (side).
- b. Push **SETUP** (front-panel)! **Run Mode** (bottom)! **Triggered** (side)
- c. Load the MODE.WFM file.

Refer to *Loading Files* on page 4-10 for file loading procedures.

- d. Push the **RUN** and **CH1** output buttons.

The LEDs above the RUN button and CH1 output connectors are on.

- e. Push the **FORCE TRIGGER** button.

Verify that the oscilloscope displays a one-cycle sine wave when the FORCE TRIGGER button is pushed. You may need to adjust the horizontal position control to see the signal.

7. Follow the substeps below to check the triggered mode with external triggering:

- a. Turn on the function generator output.
- b. Verify that the oscilloscope displays a one-cycle sine wave for each trigger supplied by the function generator. See Figure 4-7.

Retain the test hookup.

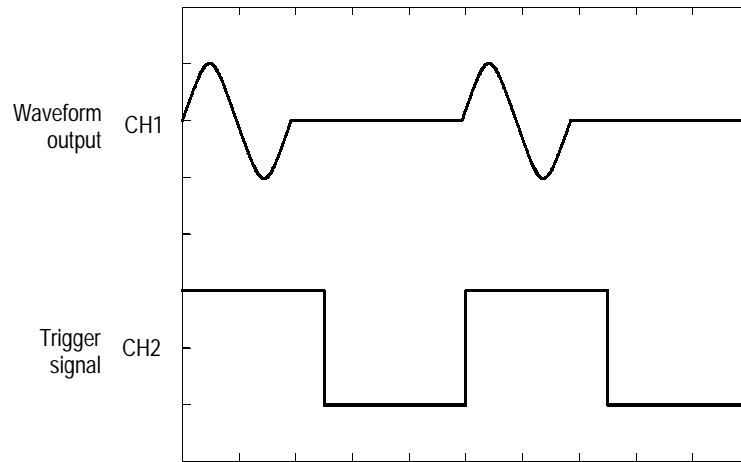

Figure 4-7: Relationship between trigger signal and waveform output

Check Gated Mode

Equipment required	Two 50 Ω BNC coaxial cables, a 50 Ω SMA coaxial cable, a SMA(Fe)-BNC(Ma) adapter, a BNC-T (male to 2 females) adapter, a function generator, and an oscilloscope (TDS700).
Prerequisites	The AWG610 Arbitrary Waveform Generator must meet the prerequisites listed on page 4-8.

1. Set the oscilloscope controls as follows:

- Vertical CH1 and CH2
- CH1 and CH2 coupling DC
- CH1 scale 0.5 V/div
- CH2 scale 2 V/div
- CH1 input impedance 50 Ω
- CH2 input impedance 1 M Ω
- Horizontal
- Sweep 20 μ s/div
- Trigger
- Source CH1
- Coupling AC
- Slope Positive
- Level 0 V
- Mode Auto

2. Set the function generator (AFG2020) controls as follows:

Function	Square
Mode	Continuous
Parameters	
Frequency	10 kHz
Amplitude	2.0 V into 50 Ω (4.0 V into 1 M Ω)
Offset	1.0 V into 50 Ω (2.0 V into 1 M Ω)
Output	Off

3. Follow the substeps below to set the AWG610 Arbitrary Waveform Generator controls and to select the waveform file:

- a.** Push **UTILITY** (front-panel)! **System** (bottom)! **Factory Reset** (side)! **OK** (side).
- b.** Push **SETUP** (front-panel)! **Run Mode** (bottom)! **Gated** (side).
- c.** Load the MODE.WFM file.

Refer to *Loading Files* on page 4-10 for file loading procedures.

- d.** Push the **RUN** and **CH1** output buttons.

The LEDs above the RUN button and CH1 output connector are on.

- e.** Push **HORIZONTAL MENU** (bottom)! **Clock** (side).
- f.** Push **1, 0, 0** and **M** (SHIFT+7) keys in this order or turn the general purpose knob to set the internal clock frequency to 100 MHz.
- g.** Push the **RUN** and **CH1** output buttons.

The LEDs above the RUN button and CH1 output connector are on.

- h.** Push the **FORCE TRIGGER** button.

Verify that the oscilloscope displays a sine wave when the FORCE TRIGGER button is pushed and that the output stops when the Force Trigger button is released.

4. Follow the substeps below to check the gated mode with the gate signal:

- a.** Set the oscilloscope trigger source to CH2.
- b.** Turn on the function generator output.
- c.** Verify that the oscilloscope displays a sine wave while the function generator gate signal amplitude is High level. See Figure 4-8.

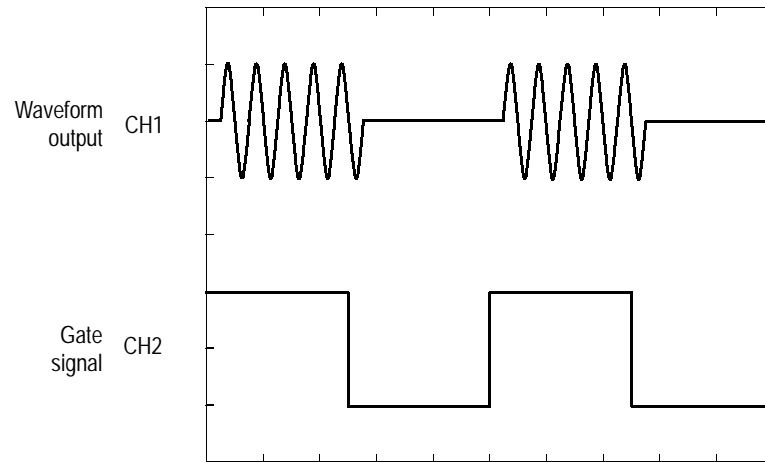

Figure 4-8: Relationship between gate signal and waveform output

d. Push **SETUP** (front-panel)! **Trigger** (bottom)! **Negative** (side).

This changes the AWG610 Arbitrary Waveform Generator trigger polarity to negative.

5. Verify that the oscilloscope displays a sine wave while the function generator gate signal amplitude is Low level.
6. Turn off the function generator output and disconnect from the oscilloscope.

Amplitude and Offset Accuracy Tests (Normal Out)

These procedures check the accuracy of the amplitude and offset outputs of the AWG610 Arbitrary Waveform Generator.

NOTE. The amplitude and offset accuracy checks are structured as a continuous test. The next test uses the control settings from the previous test and uses the next step in the sequence file.

NOTE. When you output signal from the CH1 or $\overline{CH1}$ OUTPUT, check that the other OUTPUT ($\overline{CH1}$ or CH1) LED is off. If the other OUTPUT LED is on, push the $\overline{CH1}$ or CH1 OUT button to turn off the output.

Check Amplitude Accuracy

Equipment required	A 50 Ω BNC coaxial cable, a BNC 50 Ω precision terminator, a SMA(Ma)-BNC(Fe) adapters, BNC (female)-to-dual banana adapter, and a digital multimeter (DMM).
Prerequisites	The AWG610 Arbitrary Waveform Generator must meet the prerequisites listed on page 4-8.

Do the following steps to install the test hookup and set the test equipment controls:

1. Use a 50 Ω BNC coaxial cable, an SMA(Ma)-BNC(Fe) adapter, a BNC 50 Ω precision terminator, and a BNC-to-dual banana adapter to connect the AWG610 Arbitrary Waveform Generator CH1 output to the DMM input connector (see Figure 4-9).

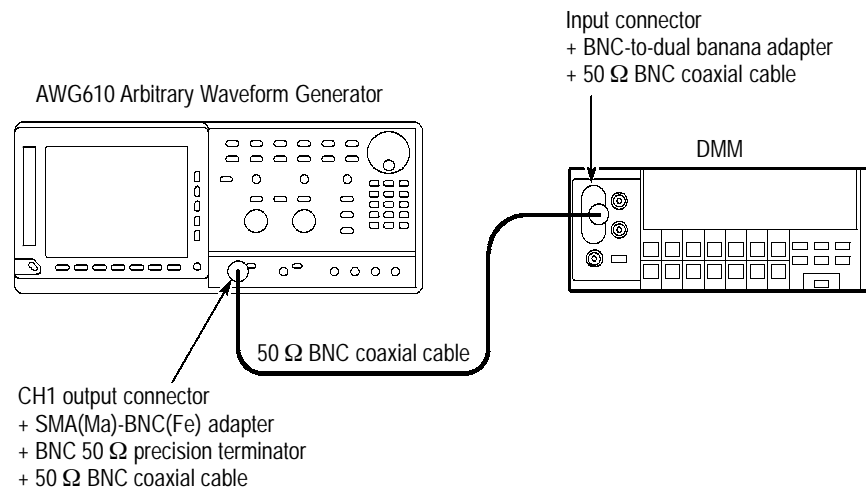

Figure 4-9: Amplitude accuracy initial test hookup

2. Set the DMM controls as follows:

Mode	VDC
Range	Auto
Input	Front

3. Follow the substeps below to set the AWG610 Arbitrary Waveform Generator controls and to select the sequence file:

- a. Push **UTILITY** (front-panel)! **System** (bottom)! **Factory Reset** (side)! **OK** (side).
- b. Push **SETUP** (front-panel)! **Run Mode** (bottom)! **Enhanced** (side).

The AWG610 Arbitrary Waveform Generator is set to enhanced mode.

- c. Load the AMP1.SEQ file.

Refer to *Loading Files* on page 4-10 for file loading procedures.

4. Push the **RUN** and **CH1** output buttons.

The LEDs above the RUN button and CH1 output connector are on.

5. Do the following substeps to set the AWG610 Arbitrary Waveform Generator amplitude and confirm the offset setting:
 - a. Push **VERTICAL MENU** (front-panel) ! **Amplitude** (side).
 - b. Push **0**, **.**, **0**, **2** and **ENTER** keys in this order or turn the general purpose knob to set the amplitude to 0.020 V.
 - c. Verify that the offset setting display on the Offset side button is 0.000 V.
If the offset display is not set correctly, push the **Offset** side button, and push **0** and then **ENTER** key.
6. Do the following substeps to check the amplitude accuracy of a 20 mV amplitude setting:
 - a. Write the DMM reading as a positive voltage.
 - b. Push the **FORCE EVENT** button.
 - c. Write the DMM reading as a negative voltage.
 - d. Verify that the positive minus negative voltages fall within $20 \text{ mV} \pm 2.3 \text{ mV}$.
 - e. Push **0**, **.**, **2** and **ENTER** keys in this order or turn the general purpose knob to set the amplitude to 0.200 V.
7. Do the following to check the amplitude accuracy of 200 mV amplitude setting:
 - a. Push the **FORCE EVENT** button.
 - b. Write the DMM reading as a positive voltage.
 - c. Push the **FORCE EVENT** button.
 - d. Write the DMM reading as a negative voltage.
 - e. Verify that the positive minus negative voltages fall within $200 \text{ mV} \pm 5 \text{ mV}$.
 - f. Push the **2** and the **ENTER** keys in this order or turn the general purpose knob to set the amplitude to 2 V.
8. Do the following substeps to check the amplitude accuracy of a 2 V amplitude setting:
 - a. Push the **FORCE EVENT** button.
 - b. Write the DMM reading as a positive voltage.
 - c. Push the **FORCE EVENT** button.

- d. Write the DMM reading as a negative voltage.
 - e. Check that the positive minus negative voltages fall within $2\text{ V} \pm 0.032\text{ V}$.
9. Do the following substeps to change the connection to check the $\overline{\text{CH1}}$:
 - a. Push the **CH1** output button.
 - b. Disconnect the adapter, terminator and cable from the **CH1** output connector.
 - c. Connect the adapter, terminator, and the cable (removed in step b) to the $\overline{\text{CH1}}$ output connector.
 - d. Push the $\overline{\text{CH1}}$ output button to turn on the $\overline{\text{CH1}}$ LED.
 10. Repeat the *Check Amplitude Accuracy* procedure for the AWG610 Arbitrary Waveform Generator $\overline{\text{CH1}}$ beginning on page 4-24.
 11. Reconnect the test hookup on the $\overline{\text{CH1}}$ output to the CH1 output. Retain the control settings.

Check Offset Accuracy

The following procedure checks the Offset Accuracy.

1. Use the test hookup and settings from previous check beginning on page 4-24.
2. Follow the substeps below to set the AWG610 Arbitrary Waveform Generator controls and to select the sequence file:
 - a. Push **UTILITY** (front-panel)! **System** (bottom)! **Factory Reset** (side)! **OK** (side).
 - b. Load the OFFSET.WFM file.
Refer to *Loading Files* on page 4-10 for file loading procedures.
 - c. Push **VERTICAL MENU** (front-panel)! **Amplitude** (side).
 - d. Push **0**, **.**, **0**, **2** and **ENTER** keys in this order or turn the general purpose knob to set the amplitude to 0.020 V.
3. Push the **RUN** and **CH1** output buttons.

The LEDs above the RUN button and CH1 output connector are on.

4. Do the following substeps to set the AWG610 Arbitrary Waveform Generator offset:
 - a. Push the **Offset** side button.
 - b. Push **0** and **ENTER** keys in this order.
 - c. Verify that the reading on the DMM falls within $0\text{ V} \pm 10\text{ mV}$.
 - d. Push **1** and **ENTER** keys in this order to change the AWG610 Arbitrary Waveform Generator offset to 1 V.
 - e. Verify that the reading on the DMM falls within $1\text{ V} \pm 0.020\text{ V}$.
 - f. Push **-**, **1** and **ENTER** keys in this order to change the AWG610 Arbitrary Waveform Generator offset to -1 V.
 - g. Check that the reading on the DMM falls within $-1\text{ V} \pm 0.020\text{ V}$.
5. Do the following substeps to change the connection to check the $\overline{\text{CH1}}$:
 - a. Push the **CH1** output button.
 - b. Disconnect the adapter, terminator and cable from the **CH1** output connector.
 - c. Connect the adapter, terminator, and cable (removed in step b) to the $\overline{\text{CH1}}$ output connector.
 - d. Push the $\overline{\text{CH1}}$ output button to turn on the $\overline{\text{CH1}}$ LED.
6. Repeat the *Check Offset Accuracy* procedure for the AWG610 Arbitrary Waveform Generator $\overline{\text{CH1}}$.
7. Push the $\overline{\text{CH1}}$ output button to turn off the $\overline{\text{CH1}}$ LED.
8. Disconnect the test hookup from the $\overline{\text{CH1}}$ output connector.

Amplitude, Offset Accuracy and Rise Time Tests (Direct DA Out)

These procedures check the accuracy of the AWG610 Arbitrary Waveform Generator direct waveform outputs; amplitude and offset.

Check Amplitude and DC Offset

Equipment required	A 50 Ω BNC coaxial cable, a BNC 50 Ω precision terminator, a SMA(Ma)-BNC(Fe) adapters, BNC (female)-to-dual banana adapter, and a digital multimeter (DMM).
Prerequisites	The AWG610 Arbitrary Waveform Generator must meet the prerequisites listed on page 4-8.

Do the following steps to install the test hookup and set the test equipment controls:

1. Use a 50 Ω BNC coaxial cable, an SMA(Ma)-BNC(Fe) adapter, a BNC 50 Ω precision terminator, and a BNC-to-dual banana adapter to connect the AWG610 Arbitrary Waveform Generator CH1 output to the DMM input connector (see Figure 4-10).

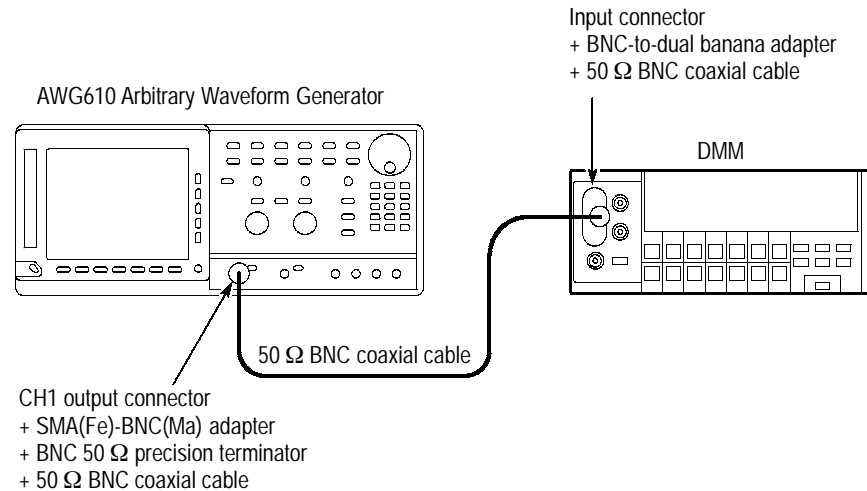

Figure 4-10: Direct DA output amplitude accuracy initial test hookup

2. Set the DMM controls as follows:

Mode VDC
 Range 2 V
 Input Front

3. Push **UTILITY** (front-panel)! **System** (bottom)! **Factory Reset** (side)! **OK** (side).
4. Push **SETUP** (front-panel)! **Run Mode** (bottom)! **Enhanced** (side).
The AWG610 Arbitrary Waveform Generator is set to enhanced mode.
5. Push **VERTICAL MENU** (front-panel)! **Output** (side)! **Direct** (side).
6. Load the AMP2.SEQ file.
Refer to *Loading Files* on page 4-10 for file loading procedures.
7. Push the **RUN** and **CH1** output buttons.
The LEDs above the RUN button and CH1 output connector are on.
8. Do the following substeps to check the direct DA amplitude accuracy of a 1 V amplitude setting:
 - a. Write the DMM reading as a positive voltage.
 - b. Push the **FORCE EVENT** button.
 - c. Write the DMM reading as a negative voltage.
 - d. Verify that the positive minus negative voltages fall within $1.0\text{ V} \pm 0.022\text{ V}$.
The LEDs above the RUN button and CH1 output connector are on.
 - e. Push **VERTICAL MENU** (front-panel)! **Amplitude** (side).
 - f. Push **0**, **.**, **0**, **2** and **ENTER** keys in this order or turn the general purpose knob to set the amplitude to 0.02 V.
9. Follow the substeps below to check the DC offset:
 - a. Push the **FORCE EVENT** button.
 - b. Check that the reading from the oscilloscope display is about $0\text{ V} \pm 10\text{ mV}$.
10. Do the following to check the direct DA amplitude accuracy of 20 mV amplitude setting:
 - a. Push the **FORCE EVENT** button.
 - b. Write the DMM reading as a positive voltage.
 - c. Push the **FORCE EVENT** button.
 - d. Write the DMM reading as a negative voltage.

- e. Verify that the positive minus negative voltages fall within $20 \text{ mV} \pm 2.4 \text{ mV}$.
11. Follow the substeps below to check the DC offset:
 - a. Push the **FORCE EVENT** button.
 - b. Check that the reading from the oscilloscope display is about $0 \text{ V} \pm 10 \text{ mV}$.
 12. Do the following substeps to change the connection to check the $\overline{\text{CH1}}$:
 - a. Push the **CH1** output button.
 - b. Disconnect the adapter, terminator and cable from the **CH1** output connector.
 - c. Connect the adapter, terminator, and cable (removed in step b) to the $\overline{\text{CH1}}$ output connector.
 - d. Push the $\overline{\text{CH1}}$ output button to turn on the $\overline{\text{CH1}}$ LED.
 13. Repeat steps 8 through step 11 for the AWG610 Arbitrary Waveform Generator $\overline{\text{CH1}}$.
 14. Push the $\overline{\text{CH1}}$ output button to turn off the $\overline{\text{CH1}}$ LED.
 15. Push the **RUN** button to turn off the RUN LED.
 16. Disconnect the DMM.

Check Pulse Rise Time

Equipment required	A 50 Ω SMA coaxial cable and an oscilloscope (TDS820).
Prerequisites	The AWG610 Arbitrary Waveform Generator must meet the prerequisites listed on page 4-8.

Do the following steps to install the test hookup and set the test equipment controls:

1. Use the 50 Ω SMA coaxial cable to connect the AWG610 Arbitrary Waveform Generator CH1 output connector to the oscilloscope CH1 input connector (see Figure 4-11).

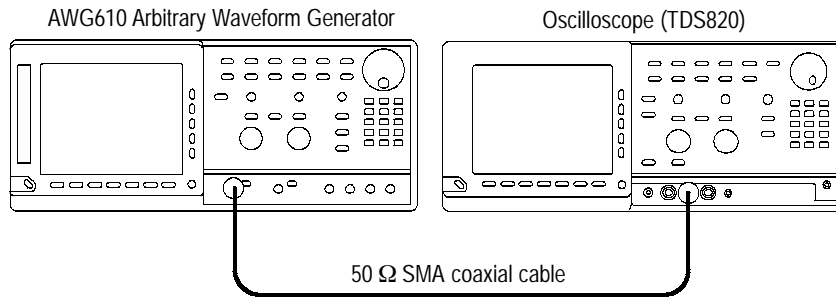



Figure 4-11: Direct DA output pulse rise time initial test hookup

2. Set the oscilloscope controls as follows:

Vertical	CH1
CH1 coupling	DC if applicable
CH1 scale	100 mV/div
Horizontal	
Sweep	500 ps/div
Trigger	
Source	CH1
Slope	
Level	0 V
Mode	Auto

NOTE. The pulse rise time tests use the AWG610 Arbitrary Waveform Generators control settings that have been used in the amplitude and DC offset tests. Do not initialize the AWG610 Arbitrary Waveform Generator controls.

3. Load the PULSE.WFM file.

Refer to *Loading Files* on page 4-10 for file loading procedures.

4. Push **SETUP** (front-panel)! **Run Mode** (bottom)! **Continuous** (side).

The AWG610 Arbitrary Waveform Generator is set to the Continuous mode.

5. Change the AWG610 Arbitrary Waveform Generator controls as follows:

a. Push **VERTICAL MENU** (bottom)! **Amplitude** (side).

b. Push **0**, **.**, **5** and **ENTER** keys in this order or turn the general purpose knob to set the amplitude to 0.5 V.

6. Push the **RUN** and **CH1** output buttons.

The LEDs above the RUN button and CH1 output connectors are on.

7. Verify that the rise time of the pulse waveform displayed on the oscilloscope is equal to or less than 400 ps.
8. Do the following substeps to change the connection to check the $\overline{\text{CH1}}$:
 - a. Push the **CH1** output button.
 - b. Disconnect the cable from the CH1 output connector.
 - c. Connect the cable to the $\overline{\text{CH1}}$ output connector.
 - d. Push the $\overline{\text{CH1}}$ output button to turn on the $\overline{\text{CH1}}$ LED.
9. Repeat step 7 to verify the rise time for the AWG610 Arbitrary Waveform Generator $\overline{\text{CH1}}$.
10. Push the $\overline{\text{CH1}}$ output button to turn off the $\overline{\text{CH1}}$ LED.

Pulse Response Tests

This procedure checks the pulse response characteristics of the AWG610 Arbitrary Waveform Generator output waveforms at amplitudes of 1 V.

Equipment required	A 50 Ω SMA coaxial cable and an oscilloscope (TDS820).
Prerequisites	The AWG610 Arbitrary Waveform Generator must meet the prerequisites listed on page 4-8.

Do the following steps to install the test hookup and set the test equipment controls:

1. Use the 50 Ω SMA coaxial cable to connect the AWG610 Arbitrary Waveform Generator CH1 output connector to the oscilloscope CH1 input connector (see Figure 4-12).

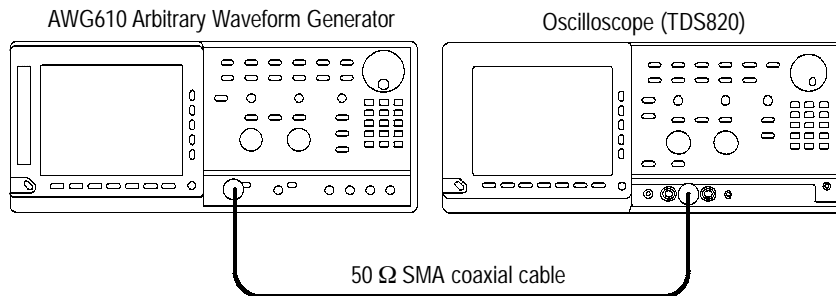

Figure 4-12: Pulse response initial test hookup

2. Set the oscilloscope controls as follows:

Vertical	CH1
CH1 coupling	DC if applicable
CH1 scale	250 mV/div (200 mV for TDS820)
Horizontal	
Sweep	500 ps/div
Trigger	
Source	CH1
Slope	Positive
Level	0 V
Mode	Auto

3. Push **UTILITY** (front-panel) **System** (bottom)! **Factory Reset** (side)! **OK** (side).
4. Load the PULSE.WFM file.
Refer to *Loading Files* on page 4-10 for file loading procedures.
5. Push the **RUN** and **CH1** output buttons.
The LEDs above the RUN button and CH1 output connector are on.
6. Verify the pulse response at 1 V amplitude by following the substeps below:
 - a. Verify that the rise time of the waveform displayed on the oscilloscope from 10% to 90% point is equal to or less than 750 ps.
 - b. Set the oscilloscope sweep to 2 ns/div.
 - c. Verify that the aberration of the displayed waveform on the oscilloscope screen is within $\pm 10\%$.
 - d. Set the oscilloscope sweep to 200 ns/div.
 - e. Verify that the flatness of the displayed waveform on the oscilloscope is within $\pm 3\%$ after 20 ns from the rising edge.
7. Do the following substeps to change the connection to check the $\overline{\text{CH1}}$:
 - a. Push the **CH1** output button.
 - b. Disconnect the cable from the CH1 output connector.
 - c. Connect the cable to the $\overline{\text{CH1}}$ output connector.
 - d. Push the $\overline{\text{CH1}}$ output button to turn on the $\overline{\text{CH1}}$ LED.
8. Repeat the *Check Pulse Response procedure* for the AWG610 Arbitrary Waveform Generator $\overline{\text{CH1}}$.
9. Push the $\overline{\text{CH1}}$ output button to turn off the $\overline{\text{CH1}}$ LED.
10. Disconnect the oscilloscope.

Sine Wave Tests

This procedure checks the sine wave characteristics of the AWG610 Arbitrary Waveform Generator output waveforms.

Equipment required	A 50 Ω SMA coaxial cable, a DC block, a BNC(Fe)-N(Ma) adapter, a SMA(Fe)-BNC(Ma) adapter, and a spectrum analyzer.
Prerequisites	The AWG610 Arbitrary Waveform Generator must meet the prerequisites listed on page 4-8.

Do the following steps to install the test hookup and set the test equipment controls:

1. Use the 50 Ω SMA coaxial cable, adapters, and DC Block to connect the AWG610 Arbitrary Waveform Generator CH1 output connector to the input connector on the spectrum analyzer (see Figure 4-13).

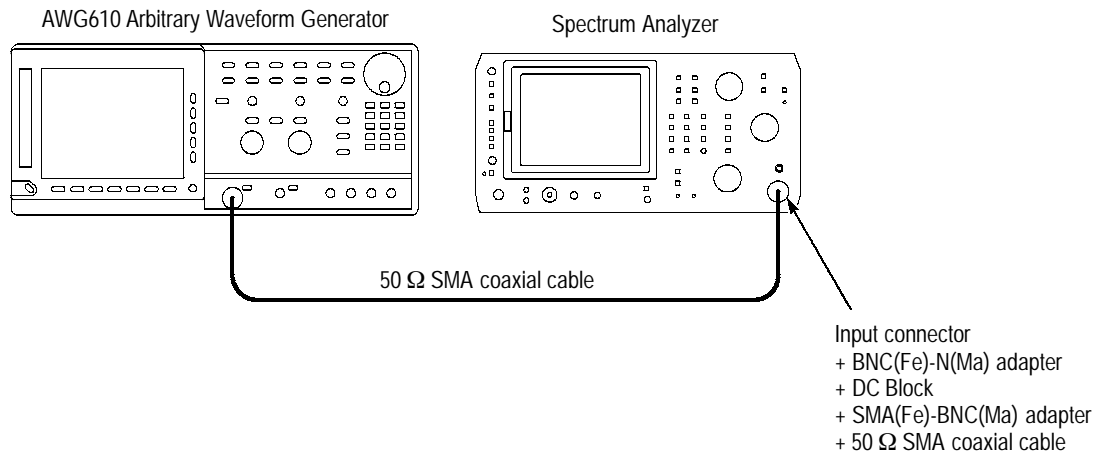

Figure 4-13: Sine wave initial test hookup

2. Set the spectrum analyzer controls as follows:

Center frequency	500 MHz
Full Span	1000 MHz
Reference level	10 dBm
RF attenuation	30 dB
Video filter	1 kHz (or 3 kHz)
Resolution BW	1 MHz (or 3 MHz)

3. Push **UTILITY** (front-panel)! **System** (bottom)! **Factory Reset** (side)! **OK** (side).

4. Load the SINE.WFM file.

Refer to *Loading Files* on page 4-10 for file loading procedures.

5. Push the **RUN** and **CH1** output buttons.

The LEDs above the RUN button and CH1 output connector are on.

6. Do the following substeps using the \square MKR function of the 497P to check the harmonics and noise level:
 - a. Verify that the harmonics level of the spectrum displayed on the spectrum analyzer from 0 Hz to 800 MHz is -40 dBc or less.
 - b. Verify that the noise level of the spectrum displayed on the spectrum analyzer from 0 Hz to 800 MHz is -50 dBc or less.
7. Push the **CH1** output button to turn off the CH1 LED.
8. Disconnect the spectrum analyzer.

Internal Trigger Tests

These procedures check internal trigger function of the AWG610 Arbitrary Waveform Generator.

NOTE. When you output signal from the CH1 or $\overline{CH1}$ OUTPUT, check that the other OUTPUT ($\overline{CH1}$ or CH1) LED is off.

If the other OUTPUT LED is on, push the $\overline{CH1}$ or CH1 OUT button to turn off the output.

Equipment required	A 50 Ω SMA coaxial cable, a SMA(FE)-BNC(Ma) adapter and an oscilloscope (TDS700).
Prerequisites	The AWG610 Arbitrary Waveform Generator must meet the prerequisites listed on page 4-8.

Do the following steps to install the test hookup and set the test equipment controls:

1. Use the coaxial cable and SMA(FE)-BNC(FE) adapter to connect the AWG610 Arbitrary Waveform Generator **CH1** output connector to the oscilloscope CH1 input connector (see Figure 4-14).

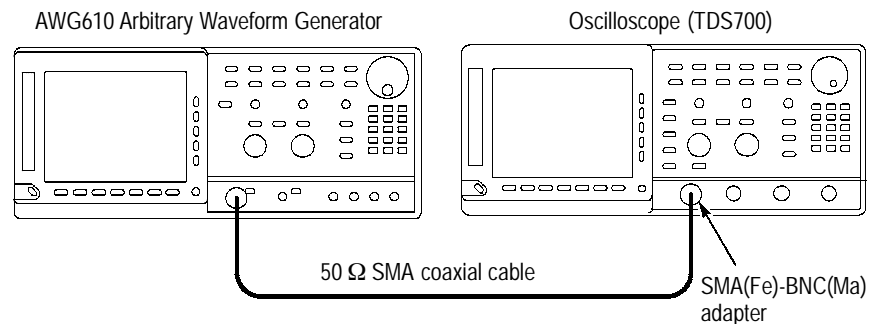

Figure 4-14: Internal trigger initial test hookup

2. Set the oscilloscope controls as follows:

Vertical	CH1
CH1 coupling	DC
CH1 scale	0.5 V/div
CH1 input impedance	50 Ω
Horizontal	

Sweep	1 ms/div
Trigger	
Source	CH1
Coupling	DC
Slope	Positive
Level	0.2 V
Mode	Auto

3. Push **UTILITY** (front-panel)! **System** (bottom)! **Factory Reset** (side)! **OK** (side).

4. Load the MODE.WFM file.

Refer to *Loading Files* on page 4-10 for file loading procedures.

5. Push **SETUP** (front-panel)! **Run Mode** (bottom)! **Triggered** (side).

6. Push **Horizontal (bottom)**! **Clock** (side)! **1, 0, 0, M (SHIFT, 7)**.

The clock is set to 100.0 MS/s.

7. Follow the substeps to set the trigger interval:

a. Push **SETUP** (front-panel)! **Trigger** (bottom)! **Source** (side)! **Internal** (side).

b. Push the **Interval** side button.

c. Push **1** and **m** (SHIFT+9) keys in this order or turn the general purpose knob to set the trigger interval to 1 ms.

The numeric value of 1m is entered.

8. Push the **RUN** and **CH1 OUT** buttons.

The LEDs above the RUN button and CH1 output connectors are on.

9. Verify that there is a single sinewave cycle displayed at 1 ms intervals.

10. Push **2** and **m** (SHIFT+9) keys in this order or turn the general purpose knob to set the trigger interval to 2 ms.

The trigger interval is changed to a value of 2 ms.

11. Verify that the period between the waveform displayed on the oscilloscope is two horizontal divisions.

12. Push the **CH1 OUT** button to turn off the CH1 LED.

Trigger Input Tests

These procedures check the trigger level accuracy of the AWG610 Arbitrary Waveform Generator.

Equipment required	A BNC-to-banana adapter, an SMA(Ma)-BNC(Fe) adapter, a 50 Ω BNC coaxial cable, a 50 Ω SMA coaxial cable, a programmable voltage source, and an oscilloscope.
Prerequisites	The AWG610 Arbitrary Waveform Generator must meet the prerequisites listed on page 4-8.

Do the following steps to install the test hookup and set the test equipment controls:

1. Use a 50 Ω SMA coaxial cable and an SMA(Fe)-BNC(Fe) adapter to connect the AWG610 Arbitrary Waveform Generator CH1 output connector to the oscilloscope CH1 input connector.
2. Connect the BNC-to-banana adapter and a 50 Ω BNC coaxial cable to the programmable voltage source output connector.
3. Connect the loose end of the 50 Ω BNC coaxial cable to the TRIG IN connector on the rear panel of the AWG610 Arbitrary Waveform Generator.

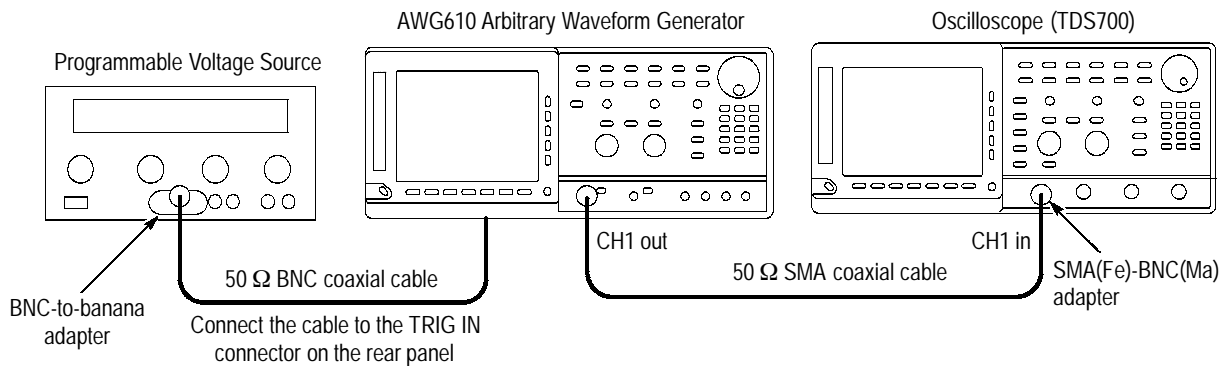

Figure 4-15: Trigger input initial test hookup

4. Set the oscilloscope controls as follows:

Vertical	CH1
CH1 coupling	DC
CH1 scale	0.5 V/div
CH1 input impedance	50 Ω
Horizontal	
Sweep	200 μ s/div
Trigger	
Source	CH1
Coupling	AC
Slope	Positive
Level	0 V
Mode	Auto

a. Set the voltage source controls as follows:

Voltage	0 V
Output	On

b. Push **UTILITY** (front-panel)! **System** (bottom)! **Factory Reset** (side)! **OK** (side).

c. Push **SETUP** (front-panel)! **Run Mode** (bottom)! **Gated** (side).

d. Load the TRIG.WFM file.

Refer to *Loading Files* on page 4-10 for file loading procedures.

5. Push the **RUN** and **CH1 OUT** buttons.

The LEDs above the RUN button and CH1 output connector are on.

6. Set the trigger level to 5 V by following the substeps below:

a. Push **SETUP** (front-panel)! **Trigger** (bottom)! **Level** (side).

b. Push **5** and **ENTER** keys in this order.

7. Set the output voltage of the voltage source to 4.65 V.

8. Check that no waveform is displayed on the oscilloscope.

9. Set the output voltage of the voltage source to 5.35 V.

10. Check that a sine wave is displayed on the oscilloscope.

- 11.** Follow the steps below to check trigger level accuracy at -5 V:
 - a.** Push **-**, **5** and **ENTER** keys in this order.
 - b.** Set the output voltage of the voltage source to -5.35 V.
 - c.** Check that no waveform is being displayed on the oscilloscope.
 - d.** Set the output voltage of the voltage source to -4.65 V.
 - e.** Check that a sine wave is displayed on the oscilloscope.
- 12.** Push the **CH1 OUT** button to turn off the CH1 LED.
- 13.** Turn off the voltage source output, disconnect the voltage source.

Event Input and Enhanced Mode Tests

These procedures check the event input signals and enhanced mode operation.

NOTE. The event input check with strobe off and the strobe input check are structured as a continuous test. After Check Event Input with Strobe Off, the next test uses the connections and oscilloscope settings from the previous test.

Check Event Input with Strobe Off

Equipment required	A 50 Ω SMA coaxial cable, a SMA(Fe)-BNC(Ma) adapter and an oscilloscope (TDS700), and custom-made ground closure. See Figure 4-3 for the connections.
Prerequisites	The AWG610 Arbitrary Waveform Generator must meet the prerequisites listed on page 4-8.

Do the following steps to install the test hookup and set the test equipment controls:

1. Use a 50 Ω SMA coaxial cable and a SMA(Fe)-BNC(Fe) adapter to connect the AWG610 Arbitrary Waveform Generator **CH1** output connector to the oscilloscope CH1 input connector (see Figure 4-16).

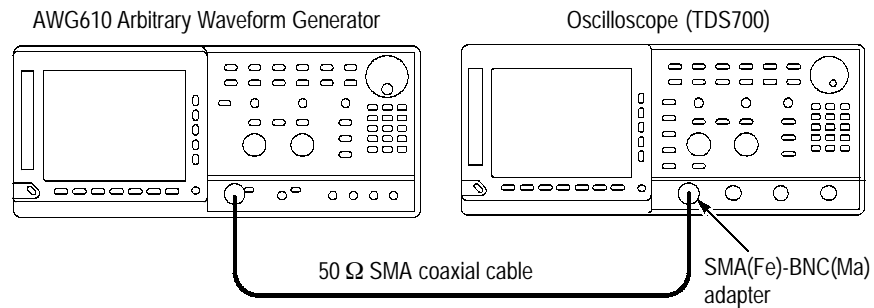

Figure 4-16: Event input and enhanced mode initial test hookup

2. Connect the ground closure to the EVENT IN connector on the AWG610 Arbitrary Waveform Generator rear panel.
3. Set the oscilloscope controls as follows:

Vertical	CH1
CH1 coupling	DC
CH1 scale	0.2 V/div
CH1 input impedance	50 Ω

Horizontal
Sweep 0.5 μ s/div

Trigger
Source CH1
Coupling DC
Slope Positive
Level +100 mV
Mode Auto

4. Set all the switches of the ground closure to open.
5. Follow the substeps below to set the AWG610 Arbitrary Waveform Generator controls and select the sequence file:
 - a. Push **UTILITY** (front-panel)! **System** (bottom)! **Factory Reset** (side)! **OK** (side).
 - b. Load the PT_EVENT.SEQ file.

Refer to *Loading Files* on page 4-10 for file loading procedures.

- c. Push **SETUP** (front-panel)! **Run Mode** (bottom)! **Enhanced** (side) to set the enhanced mode.
6. Push the **RUN** and **CH1 OUT** buttons.
The LEDs above the RUN button and CH1 output connector are on.
7. Check the EVENT IN connector pin 0 input by doing the following substeps:
 - a. Verify that the waveform being displayed on the oscilloscope is about the same amplitude as shown in Figure 4-17.

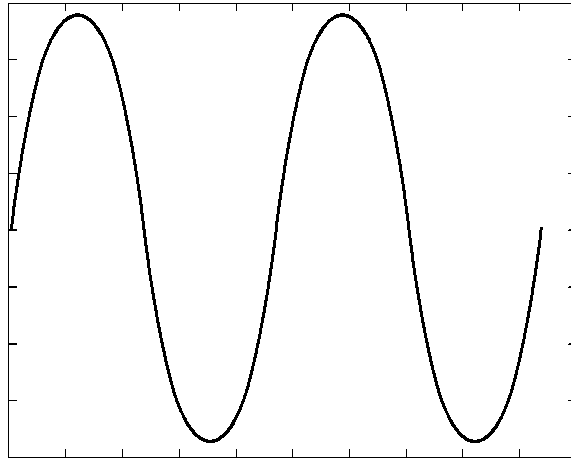

Figure 4-17: Waveform while all ground disclosure switches are open

- b.** Close the SW1 of the ground closure to generate an event signal on the EVENT IN connector pin 0.
- c.** Verify that the oscilloscope displays the waveform as shown in Figure 4-18 and that the waveform is about half the amplitude as that shown in Figure 4-17.

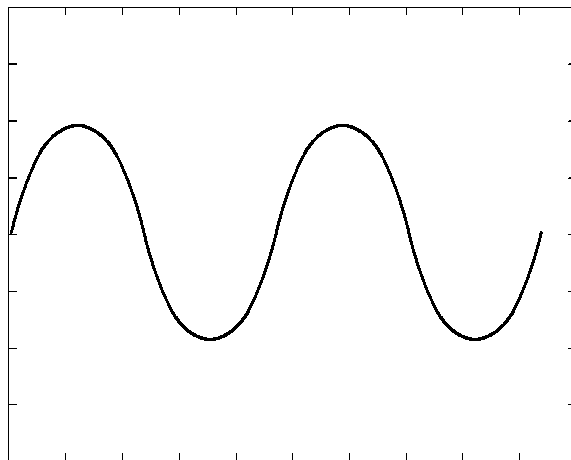

Figure 4-18: Waveform output when the SW1 is closed

- d.** Open SW1 of the ground closure to degenerate the event signal.
- e.** Verify that the oscilloscope displays the waveform in Figure 4-17.

- 8.** Check the EVENT IN connector pin 1 input by following the substeps below:
 - a.** Close SW2 of the ground closure to generate an event signal on the EVENT IN connector pin 1.
 - b.** Verify that the oscilloscope displays the waveform as shown in Figure 4-19.

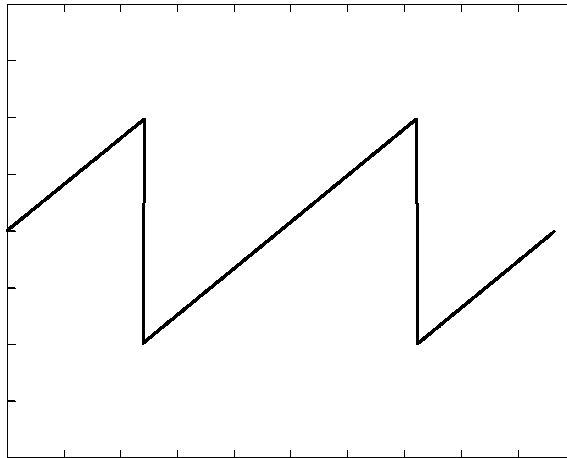

Figure 4-19: Waveform output when SW2 is closed

- c.** Open the SW2 of the ground closure to degenerate the event signal.
 - d.** Verify that the oscilloscope displays the waveform shown in Figure 4-17.
- 9.** Check the EVENT IN connector pin 2 input by following the steps below:
 - a.** Close SW3 of the ground closure to generate an event signal on the EVENT IN connector pin 2.
 - b.** Verify that the oscilloscope displays the waveform shown in Figure 4-20.

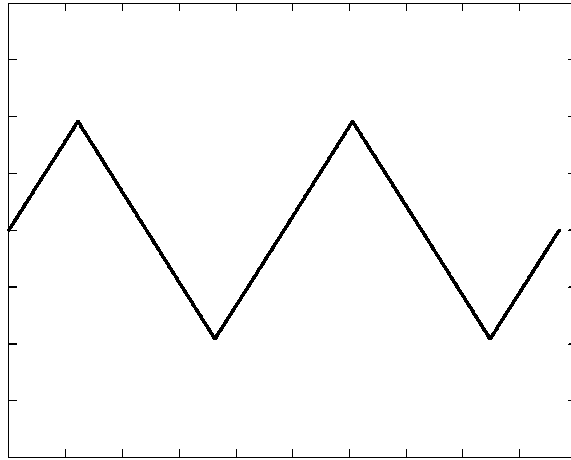

Figure 4-20: Waveform output when the SW3 is closed

- c. Open SW3 of the ground closure to degenerate the event signal.
 - d. Verify that the oscilloscope displays the waveform in Figure 4-17.
- 10.** Check the EVENT IN connector pin 3 input by doing the following substeps:
 - a. Close the SW4 of the ground closure to generate an event signal on the EVENT IN connector pin 3.
 - b. Verify that the oscilloscope displays the waveform shown in Figure 4-21.

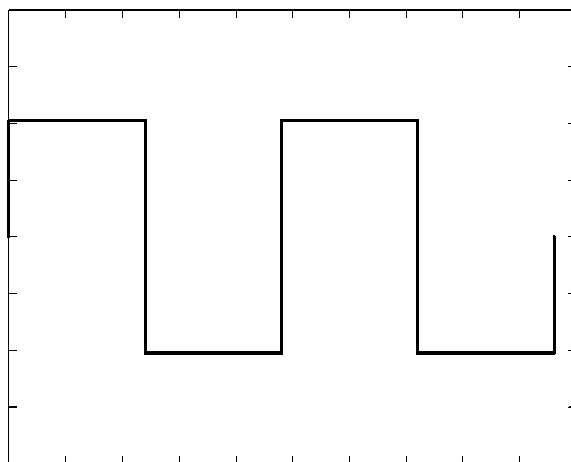

Figure 4-21: Waveform output when SW4 is closed

- c. Open SW4 of the ground closure to degenerate the event signal.
 - d. Verify that the oscilloscope displays the waveform in Figure 4-17.
11. Retain the test hookup and control settings.

Check Strobe Input

Use the test hookup and oscilloscope settings from previous check.

1. Follow the substeps below to set the AWG610 Arbitrary Waveform Generator controls and select the sequence file:
 - a. Push **UTILITY** (front-panel)! **System** (bottom)! **Factory Reset** (side)! **OK** (side).
 - b. Load the PT_STROB.SEQ file.

Refer to *Loading Files* on page 4-10 for file loading procedures.

- c. Push **SETUP** (front-panel)! **Run Mode** (bottom)! **Enhanced** (side) to set the run mode to enhanced.
2. Push the **RUN** and **CH1 OUT** buttons.

The LEDs above the RUN button and CH1 output connector are on.
3. Check the EVENT IN connector strobe pin input by doing the following substeps:
 - a. Verify that the waveform being displayed on the oscilloscope is shown in Figure 4-22.

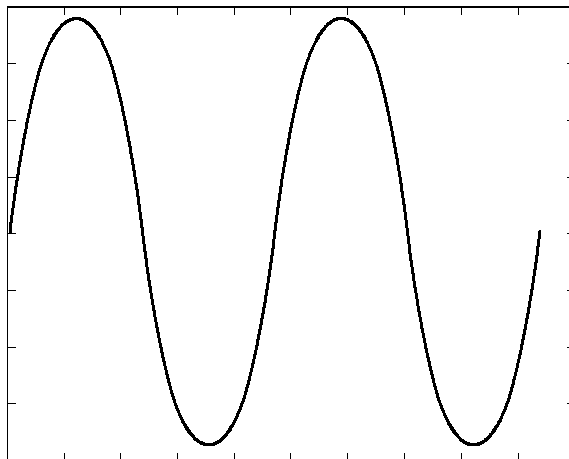

Figure 4-22: Initial waveform output

- b. Close SW5 of the ground closure to generate an event signal on the EVENT IN connector strobe pin.
- c. Verify that the oscilloscope displays the DC waveform as shown in Figure 4-23.

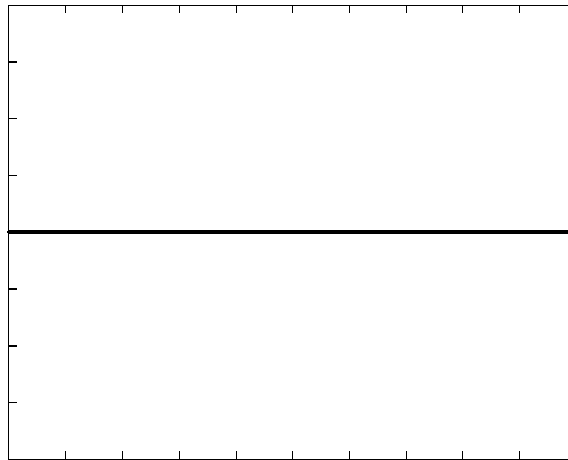

Figure 4-23: DC waveform output when the SW5 is closed

- d. Open SW5 of the ground closure to degenerate the strobe signal on the EVENT IN connector strobe pin.
 - e. Verify that the DC waveform is displayed on the oscilloscope.
 - f. Close SW5 of the ground closure again.
 - g. Verify that the oscilloscope displays the waveform as shown in Figure 4-22.
4. Push the **CH1 OUT** button to turn off the CH1 LED.
 5. Disconnect the oscilloscope and ground closure.

1/4 Clock Frequency and 10 MHz Reference Input Tests

These procedures check the 10 MHz reference input function of the AWG610 Arbitrary Waveform Generator.

Equipment required	Two 50 Ω BNC coaxial cables, a frequency counter, and a function generator.
Prerequisites	The AWG610 Arbitrary Waveform Generator must meet the prerequisites listed on page 4-8.

Do the following steps to install the test hookup and set the test equipment controls:

1. Use a 50 Ω BNC coaxial cable to connect the AWG610 Arbitrary Waveform Generator 1/4 CLOCK OUT connector to the input A connector on the frequency counter.
2. Use a 50 Ω BNC coaxial cable to connect the AWG610 Arbitrary Waveform Generator 10 MHz REF IN connector to the function generator output connector (see Figure 4-24).

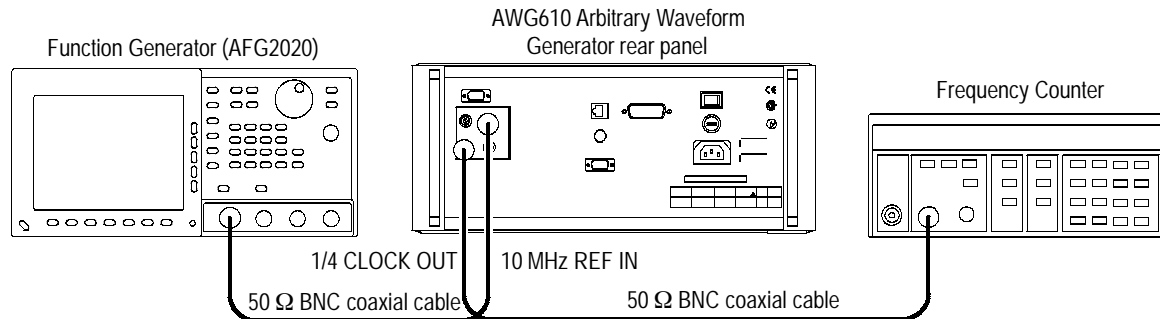

Figure 4-24: 10 MHz reference initial test hookup

- a. Set the frequency counter controls as follows:

INPUT A
 Coupling AC
 FUNCTION A FREQ
 Gate time 0.2 s
 Trigger Level 0 V

b. Set the function generator (AFG2020) controls:

Function	Square
Mode	Continuous
Parameters	
Frequency	10 MHz
Amplitude	2.0 V into 50 Ω (4.0 V into 1 M Ω)
Offset	0 V
Output	On

Check 1/4 Clock
frequency

1. Follow the substeps below to set the AWG610 Arbitrary Waveform Generator controls and select the waveform file:
 - a. Push **UTILITY** (front-panel)! **System** (bottom)! **Factory Reset** (side)! **OK** (side).

b. Load the MODE.WFM file.

Refer to *Loading Files* on page 4-10 for file loading procedures.

- c. Push **HORIZONTAL MENU** (front-panel)! **Clock** (side).
 - d. Push **2, 0, 0** and **M** (SHIFT+7) keys in this order or turn the general purpose knob to set the internal clock frequency to 200 MHz.
2. Push the **RUN** button.

The LED above the RUN button is on.

3. Verify that the frequency counter reading is 50 MHz \pm 50 Hz.
4. Retain the test hookup.

Check 10MHz Reference
Input

5. Push **HORIZONTAL MENU** (front-panel)! **Clock Ref** (side) so that the AWG610 Arbitrary Waveform Generator clock reference is set to External.
6. Verify that the frequency counter reading is 50.0 MHz \pm 10 kHz (using external reference clock).
7. Modify the function generator controls as follows:

Frequency	10.1 MHz
-----------------	----------
8. Check that the frequency counter reading is 50.5 MHz \pm 10 kHz.
9. Turn the function generator output off and disconnect the function generator and frequency counter.

1/4 Clock Output Level Tests

These procedures check the AWG610 Arbitrary Waveform Generator clock output signal.

Equipment required	A 50 Ω BNC coaxial cable and an oscilloscope.
Prerequisites	The AWG610 Arbitrary Waveform Generator must meet the prerequisites listed on page 4-8.

Do the following steps to install the test hookup and set the test equipment controls:

1. Use the 50 Ω BNC coaxial cable to connect the AWG610 Arbitrary Waveform Generator 1/4 CLOCK OUT output to the oscilloscope input connector (see Figure 4-25).

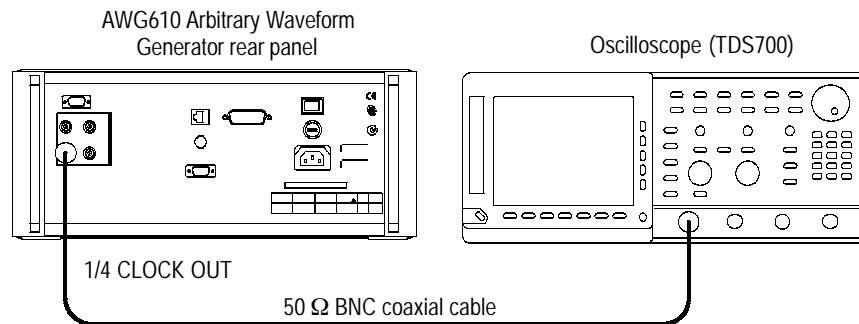

Figure 4-25: Clock output initial test hookup

2. Set the oscilloscope controls as follows:

Vertical	CH1
CH1 coupling	DC
CH1 scale	0.5 V/div
CH1 offset	-1.3 V
CH1 input impedance	1 M Ω
Horizontal	
Sweep	5 ns/div
Trigger	
Source	CH1
Coupling	AC
Slope	Positive
Level	0 V
Mode	Auto

3. Follow the substeps below to set the AWG610 Arbitrary Waveform Generator controls:
 - a. Push **UTILITY** (front-panel)! **System** (bottom)! **Factory Reset** (side)! **OK** (side).
 - b. Load the MODE.WFM file.

Refer to *Loading Files* on page 4-10 for file loading procedures.

- c. Push **HORIZONTAL MENU** (front-panel)! **Clock** (side).
 - d. Push **2, 0, 0** and **M** (SHIFT+7) keys in this order or turn the general purpose knob to set the internal clock frequency to 200 MHz.
4. Push the **RUN** button.

The LED above the RUN button is on.
5. Verify that the clock signal amplitude is equal to or larger than 0.5 V, and the clock signal period is 20 ns (50 MHz).
6. Disconnect the cable from the **1/4 Clock** connector.

10 MHz Reference Output Level Tests

These procedures check the AWG610 Arbitrary Waveform Generator clock output signal.

Equipment required	A 50 Ω BNC coaxial cable and an oscilloscope.
Prerequisites	The instrument must meet the prerequisites listed on page 4-8.

Do the following steps to install the test hookup and set the test equipment controls:

1. Use the 50 Ω BNC coaxial cable to connect the AWG610 Arbitrary Waveform Generator 10 MHz REF OUT output to the oscilloscope input connector (see Figure 4-25).

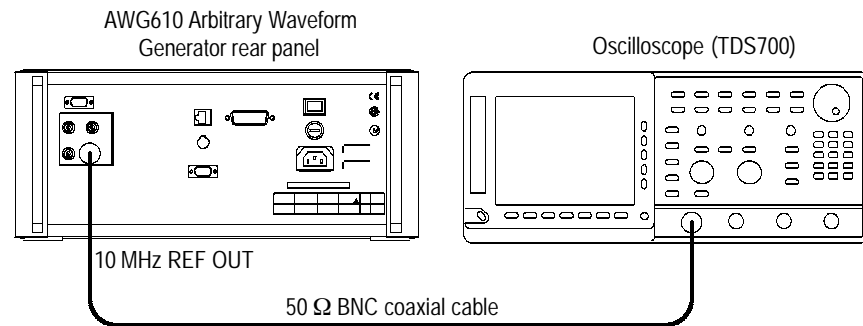

Figure 4-26: Clock output initial test hookup

2. Set the oscilloscope controls as follows:

Vertical	CH1
CH1 coupling	DC
CH1 scale	0.2 V/div
CH1 offset	0 V
CH1 input impedance	50 Ω
Horizontal	
Sweep	25 ns/div
Trigger	
Source	CH1
Coupling	AC
Slope	Positive
Level	0 V
Mode	Auto

3. Follow the substeps below to set the AWG610 Arbitrary Waveform Generator controls:
 - a. Push **UTILITY** (front-panel)! **System** (bottom)! **Factory Reset** (side)! **OK** (side).
 - b. Load the MODE.WFM file.

Refer to *Loading Files* on page 4-10 for file loading procedures.

- c. Push **HORIZONTAL MENU** (front-panel)! **Clock** (side).
 - d. Push **2, 0, 0** and **M** (SHIFT+7) keys in this order or turn the general purpose knob to set the internal clock frequency to 200 MHz.
4. Push the **RUN** button.

The LED above the RUN button is on.
5. Verify that the 10 MHz REF OUT clock signal amplitude is equal to or larger than 1.0 V, and the clock signal period is about 100 ns.
6. Disconnect and remove the BNC cable.

Marker Output Tests

These procedures check the accuracy of the AWG610 Arbitrary Waveform Generator marker output level.

Equipment required	A 50 Ω SMA coaxial cable, an SMA(Fe)-BNC(Ma) adapter, a 50 Ω SMA terminator, and an oscilloscope.
Prerequisites	The AWG610 Arbitrary Waveform Generator must meet the prerequisites listed on page 4-8.

NOTE. Connect a 50 Ω SMA terminator to the inverted marker output connector during the marker output tests.

Do the following steps to install the test hookup and set the test equipment controls:

1. Use an SMA coaxial cable and an SMA-to-BNC adapter to connect the AWG610 Arbitrary Waveform Generator MARKER1 connector to the oscilloscope CH1 input connector (see Figure 4-27).
2. Connect a 50 Ω SMA terminator to the MARKER1 connector.

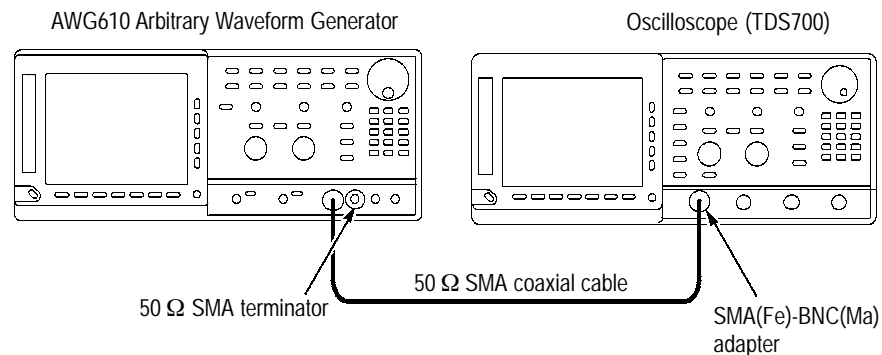

Figure 4-27: Marker output initial test hookup

3. Set the oscilloscope controls as follows:

Vertical	CH1
CH1 coupling	DC
CH1 scale	1 V/div
CH1 input impedance	50 Ω
CH1 offset	0 V

Horizontal	
Sweep	2 μ s/div
Trigger	
Source	CH1
Coupling	AC
Slope	Positive
Level	0 V
Mode	Auto

4. Follow the substeps below to set the AWG610 Arbitrary Waveform Generator controls and select the waveform file:
 - a. Push **UTILITY** (front-panel)! **System** (bottom)! **Factory Reset** (side)! **OK** (side).
 - b. Load the MODE.WFM file.

Refer to *Loading Files* on page 4-10 for file loading procedures.

5. Push **HORIZONTAL MENU** (front-panel)! **Clock** (side).
6. Push **1, 0, 0** and **M** (SHIFT+7) keys in this order or turn the general purpose knob to set the clock rate to 100 MS/s.
7. Push the **RUN** and **CH1 OUT** buttons.

The LEDs above the RUN button and CH1 output connectors are on.

NOTE. Always perform the marker level measurements after the level has stabilized. The marker level measurements do not include the overshoot or undershoot.

8. Follow the substeps below to set the Marker1 controls and check the marker output level :
 - a. Push **VERTICAL MENU** (front-panel)! **Marker...** (side)! **Marker1 Low Level** (side).
 - b. Push **-, 1, ., 1** and **ENTER** keys in this order or turn the general purpose knob to set the marker1 low level to -1.1 V.
 - c. Verify that the reading for the low level on the oscilloscope screen is within the range between -1.255 V and -0.945 V.
 - d. Push **Marker1 High Level** (side).
 - e. Push **3, ., 0** and **ENTER** keys in this order or turn the general purpose knob to set the marker1 high level to 3.0 V.

- f. Verify that the reading for the high level on the oscilloscope screen is within the range between 2.75 V and 3.25 V.
 9. Do the following substeps to change the connection to the MARKER1 output:
 - a. Disconnect the 50 Ω SMA terminator from the MARKER1 connector.
 - b. Disconnect the 50 Ω SMA coaxial cable from MARKER1 connector and connect it to MARKER1.
 - c. Connect the 50 Ω SMA terminator to the MARKER1 connector.
 - d. Push the CH1 output button to turn on the CH1 LED.
 10. Repeat step 8 to check the MARKER1 output.
 11. Repeat steps 1 through step 10 to check the MARKER2 and MARKER2 outputs.
 12. Disconnect the oscilloscope.

Marker Delay Tests

These procedures check the marker delay function of the AWG610 Arbitrary Waveform Generator.

Equipment required	Two 50 Ω SMA coaxial cables, two SMA(Fe)-BNC(Ma) adapters, two 50 Ω SMA terminators and an oscilloscope.
Prerequisites	The AWG610 Arbitrary Waveform Generator must meet the prerequisites listed on page 4-8.

NOTE. Connect two 50 Ω SMA terminators to the each inverted marker output connectors, during the marker output tests.

NOTE. Two 50 Ω SMA coaxial cables must have same length.

Do the following steps to install the test hookup and set the test equipment controls:

1. Use the 50 Ω SMA coaxial cables and SMA-to-BNC adapters to connect the AWG610 Arbitrary Waveform Generator MARKER1 and MARKER2 outputs to the oscilloscope CH1 and CH2 input connectors (see Figure 4-28).
2. Connect a 50 Ω SMA terminator to the MARKER1 and a 50 Ω SMA terminator to the MARKER2 connectors.

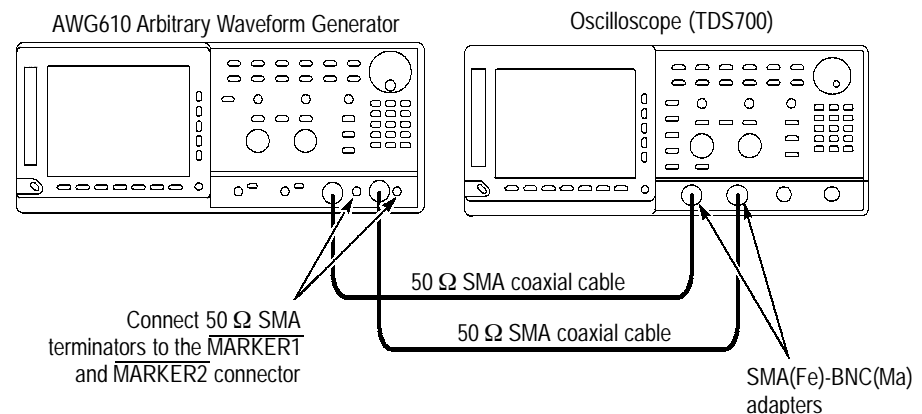

Figure 4-28: Digital data output initial test hookup

3. Set the oscilloscope controls as follows:

Vertical	CH1 and CH2
CH1 and CH2 coupling	DC
CH1 and CH2 scale	1 V/div
CH1 and CH2 offset	0 V
CH1 and CH2 input impedance ...	50 Ω
Horizontal	
Sweep	500 ps/div
Trigger	
Source	CH2
Coupling	DC
Slope	Positive
Level	1 V
Mode	Normal

4. Follow the substeps below to set the AWG610 Arbitrary Waveform Generator controls and select the waveform file:

- a.** Push **UTILITY** (front-panel)! **System** (bottom)! **Factory Reset** (side)! **OK** (side).
- b.** Load the MODE.WFM file.

Refer to *Loading Files* on page 4-10 for file loading procedures.

5. Push the **RUN button.**

The LED above the RUN button is on.

6. Follow the substeps below to verify that the Marker1 delay function is operating correctly:

- a.** Push **HORIZONTAL MENU** (front-panel)! **Marker1 Delay** (side)
- b.** Continuously change the Marker1 delay from 0 s to 1.5 ns by turning the general purpose knob.
- c.** Verify that the Marker1 output delay is relative to the Marker2 output and varies from 0 s to 1.5 ns on the oscilloscope screen.
- d.** Verify that the Marker1 output delay relative to the Marker2 output is in 1.05 ns to 1.65 ns at marker1 delay setting is 1.5 ns.

7. Push **0 and **ENTER** keys on the AWG610 Arbitrary Waveform Generator to set the Marker1 Delay back to 0 s.**

8. Change the oscilloscope trigger source from CH2 to CH1.

Trigger
Source CH1

9. Verify that the Marker2 delay function is operating correctly:
 - a. Push the **Marker2 Delay** side button.
 - b. Continuously change the Marker2 delay from 0 s to 1.5 ns by turning the general purpose knob.
 - c. Verify that the Marker2 output delay relative to the Marker1 output and varies from 0 s to 1.5 ns on the oscilloscope screen.
 - d. Verify that the Marker2 output delay relative to the Marker1 output is in 1.05 ns to 1.65 ns at marker2 delay setting is 1.5 ns.
10. Disconnect the oscilloscope.



Adjustment Procedures

Adjustment Procedures

This section contains information needed to manually adjust the AWG610 Arbitrary Waveform Generators.

Overview

- Description** This section is divided into the following subsections:
- H *Overview*. Provides basic information about adjustment requirements
 - H *Before Adjustments*. Provides general information about adjusting the waveform generator and the Performance Check/Adjustment disk files.
 - H *Adjustment Instructions*. Provides procedures for manually adjusting the waveform generator.
- Purpose** Use the *Adjustment Instructions* subsection to return the waveform generator to conformance with the performance specified in the *Specifications* section. This procedure is not required to verify the performance of the waveform generator. To verify the performance of the instrument, refer to the *Performance Verification* section.
- Adjustment Interval** Generally, these adjustments should be done every 12 months.
- Adjustment After Repair** After the removal and replacement of a module due to electrical failure, do the adjustment procedures, as listed in Table 5-1.

Table 5-1: Adjustments required

Removed and replaced module	Adjustments required
A40 Clock board	Reference Clock frequency
A50 AWG board and Flash disk	Calibration and Marker level
A70 Analog Output board	Calibration
Other modules	No need to adjust

- Adjustments** There are three adjustment procedures, as listed in Table 5-2. You can do Calibration and Marker level adjustment without removing the cabinet.

Table 5-2: Adjustments

Adjustments	Refer to
Calibration	Page 4-3
Clock frequency	Page 5-7
Marker level	Page 5-10

Before doing the adjustments, note the following requirements.

Personnel This procedure is only to be performed by trained service technicians.

Warm-Up Period This waveform generator requires a 20 minute warm-up time in a 20_ C to 30_ C environment before it is adjusted. Adjustments done before the operating temperature has stabilized may cause errors in performance.

Access An additional cooling fan must be provided, if you need to remove the cabinet when making the adjustments in this procedure. Refer to *Before Adjustments* on the next page for detailed information.

Self Calibration Calibrate the waveform generator using the self calibration routine. Refer to the *Performance Verification* section for instructions.

Performance Check/Adjustments Files These adjustment procedures require you to load a file from the Performance Check/Adjustment disk supplied with the waveform generator. Refer to *Adjustment Instructions* in this subsection for information about this file.

Test Equipment Table 5-3 lists all test equipment required to adjust the waveform generator.

Equipment Required Table 5-3 lists the test equipment required to adjust the waveform generator.

Table 5-3: Test equipment

Item description	Minimum requirements	Example	Purpose
1. Oscilloscope	Bandwidth > 500 MHz	Tektronix TDS784D	Output signal adjustments
2. Frequency counter	1 MHz to 10 MHz Accuracy < 0.2 ppm	Anritsu MF1603A	Output signal adjustment
3. BNC cable	Impedance 50 Ω	Tektronix part 012-0482-00	Signal interconnection
4. SMA cable	Impedance 50 Ω	Tektronix part 012-1565-00 or equivalent	Signal interconnection
5. Adapter	SMA (Fe) to BNC (Ma), 50 Ω	Tektronix part number 015-0572-00	Signal interconnection
6. SMA Terminator	50 Ω , SMA male	Tektronix part number 015-1022-00	Signal termination
7. Adjustment Tool	Less than 1/8 inch diameter and over 4 inches long		Enabling service mode
8. Performance check disk	Must use example listed	Tektronix part 063-3218-00	Used to provide waveform files

Before Adjustments

The following instructions prepare the waveform generator for adjustment, loading the adjustment file required for these procedures, and making adjustments.

Providing Access

Before doing the Reference Clock adjustment, remove the waveform generator rear cover and cabinet. See the *Maintenance* section for instructions on removing the cabinet and replacing it after adjustment is done.



CAUTION. To avoid damaging the eject button, remove the floppy disk (if present) from the floppy disk drive before removing the cabinet.

Cooling With the rear cover and cabinet removed, the waveform generator assembly does not cool properly while power is applied. A separate fan is needed to prevent heat build-up. Place the fan so it blows air to the A50 AWG board, as shown in Figure 5-1.



***CAUTION.** To prevent damage to the waveform generator due to over-heating, do not do the adjustment procedures without providing additional cooling, as described below.*

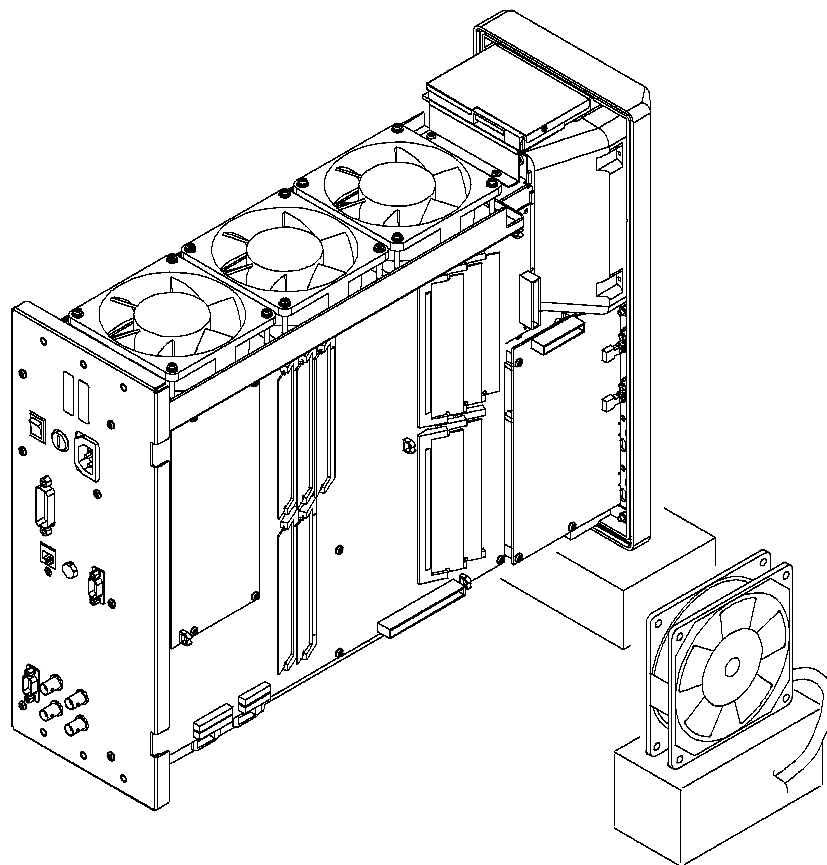

Figure 5-1: Cooling the waveform generator during adjustment procedures

Enabling Service Mode

The Marker level adjustment procedure uses the Service menu that is a submenu of the Utility menu. To enter this menu, you must do the following step to enable service mode using the switch on the A11 Connector board:

Power on the waveform generator by pushing **ON/STB** button while pressing the service switch on the A11 Connector board. See Figure 5-2.

If you perform the adjustment procedure without removing the cabinet, you must insert the adjustment tool (Item 7) in the hole on the left side of the waveform generator to engage the service switch.

Powering off the waveform generator disables the service mode.

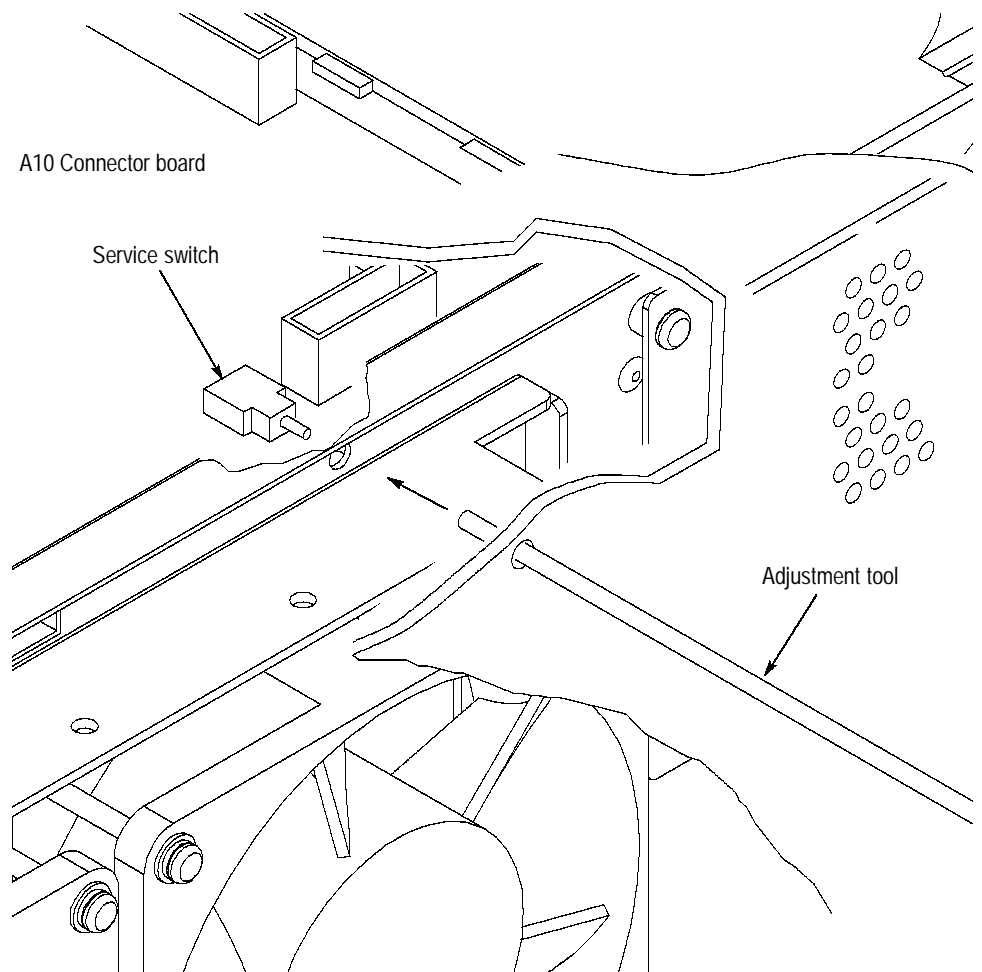

Figure 5-2: Accessing the service switch

**Performance
Check/Adjustment Files**

Table 5-4 lists the waveform file provided on the Performance Check/Adjustment disk that is required to do the adjustments.

For instructions on loading files, see *Operating Basics:Loading Files* and the *Reference:Waveform Sequence Menu* section of the User Manual. After loading the files, press the floppy disk drive eject button and remove the floppy disk.

Table 5-4: File list for Performance Check/Adjustment disk

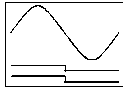
No.	File name	Wfm shape	Wfm Point	Clock	Usage
1	MODE.WFM		1000	2.6 GHz	Clock frequency adjustment, and Marker Level adjustment

Adjustment Instructions

Reference Clock Frequency

This procedure adjusts Y120 on the A40 Clock board to set the AWG610 clock frequency.

Equipment Required	One frequency counter (Item 2)
	One 50 Ω coaxial cable (Item 3)

NOTE. After step 6 of this procedure performed removing the cabinet. Recommended to save time, check the clock frequency before remove the cabinet.

Do the following steps to connect the test equipment and set test equipment controls:

1. Use a 50 Ω BNC coaxial cable to connect the waveform generator 10 MHz REF OUT connector to the input A connector on the frequency counter.

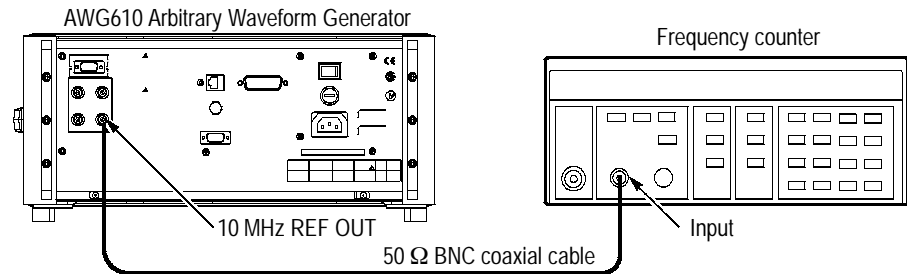

Figure 5-3: Hookup for the reference clock frequency adjustment

2. Set frequency counter controls as follows:

Input A Coupling	AC
Function	A Frequency
Gate Time	0.2 s
Level	0 V

3. Set waveform generator controls as follows:
Press **UTILITY** → **System** → **Factory Reset** → **OK**.
4. Follow the substeps below to load the waveform:
 - a. Press **SETUP** → **Waveform/Sequence** → **Load...**
 - b. Turn the general purpose knob to display the list of waveform files and highlight the file **MODE.WFM**.
 - c. Press **OK** to select and load the file.
 - d. Press **RUN** button to start the clock generation.
5. Check that the frequency counter reading is in the range of 10.0 MHz \pm 2 Hz (0.2 ppm). If necessary proceed to step 6.
6. Follow the substeps below to remove the cabinet:
 - a. Power off the waveform generator and disconnect all cables.
 - b. Remove the waveform generator rear cover and cabinet. Refer to the *Maintenance:Removal and Installation Procedures* section beginning on page 6-19.
7. Set the waveform generator as instructed in the *Adjustment Procedures: Cooling* section on page 5-4.
8. Press **UTILITY** → **System** → **Factory Reset** → **OK**.
The waveform generator is reset to factory settings.
9. Adjust Y120 on the A40 Clock board so that the frequency counter reading is in the range of 10.0 MHz \pm 2 Hz (0.2 ppm). Refer to Figure 5-4.

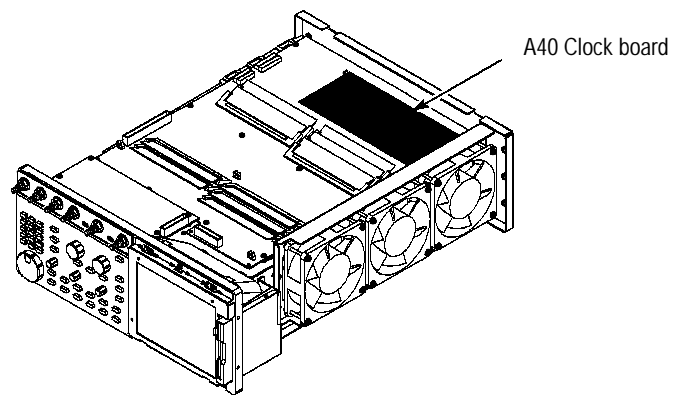
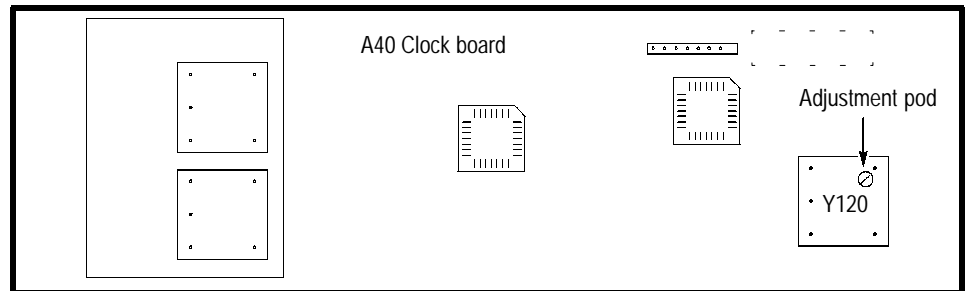

Figure 5-4: Adjustment location for clock frequency

10. Disconnect the frequency counter.
11. Replace the waveform generator rear cover and cabinet. Refer to *Maintenance: Removal and Installation Procedures* beginning on page 6-19.

Marker Level This procedure adjusts the general purpose knob on the front panel to set the Marker Output level.

Equipment Required	One oscilloscope (Item 1) One SMA 50 Ω coaxial cable (Item 4) SMA (Fe) to BNC (Ma) 50 Ω adapter (Item 5) 50 Ω SMA Terminator (Item 6)
---------------------------	---

Do the following steps to connect the test equipment and set test equipment controls:

1. Use a SMA coaxial cable and a SMA (Fe) to BNC (Ma) adapter to connect the waveform generator **MARKER 1** Output connector to the CH1 input connector on the oscilloscope.
2. Connect a 50 Ω SMA terminator to the waveform generator **MARKER 1** Output connector.

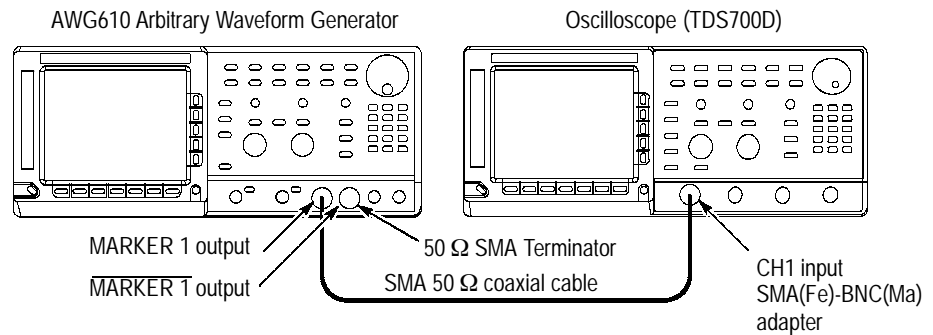

Figure 5-5: Hookup for the Marker level adjustment

- a. Set the oscilloscope controls as follows:

Vertical	CH1
CH1 coupling	DC
CH1 scale	100 mV/div
CH1 input impedance	50 Ω
Horizontal	
Sweep	5 μ s/div
Trigger	
Source	CH1
Coupling	DC
Slope	Positive
Level	+500 mV
Mode	Auto

3. Do the following to set the waveform generator controls:

Press **UTILITY** \rightarrow **System** \rightarrow **Factory Reset** \rightarrow **OK**.

4. Follow the substeps below to load the waveform:

a. Press **SETUP** \rightarrow **Waveform/Sequence** \rightarrow **Load...**

b. Turn the general purpose knob to display the list of waveform files and highlight the file **MODE.WFM**.

Press **OK** to select and load the file.

c. Press the **RUN** button.

5. Follow the substeps below to setup the Marker:

a. Press **Horizontal** \rightarrow **Clock**.

b. Turn the general purpose knob to set the Clock to 100 MS/s.

c. Press **Vertical** \rightarrow **Marker...** \rightarrow **Marker 1 High Level**

d. Turn the general purpose knob to set the voltage to 1.50 V.

e. Press **Marker 2 High Level**.

f. Turn the general purpose knob to set the voltage to 1.50 V.

g. Check that the **Marker 1 low Level** and the **Marker 2 Low Level** are 0.00 V. If there are not, set the voltage to 0.00 V in the same way.

- 6.** Follow the substeps below to adjust Marker 1 level:
 - a.** Press **UTILITY → Service**
 - b.** Turn the general purpose knob to select **Tweak AWG 1**.
 - c.** Press **OK**.
 - d.** Press **Marker 1 Adj. Level**.
 - e.** Set the oscilloscope CH1 input to GND. And, note the ground position. Then return the CH1 input to 50 Ω DC.
 - f.** Turn the general purpose knob to adjust the waveform of marker low level voltage to 0.00 V within ± 50 mV on the oscilloscope display.
- 7.** Disconnect the SMA coaxial cable from the waveform generator MARKER 1 Output, then reconnect it to the MARKER 2 Output connector.
- 8.** Remove the 50 Ω SMA Terminator from the waveform generator MARKER 1 Output, then reconnect it to the MARKER 2 Output connector.
- 9.** Follow the substeps below to adjust the Marker 2 level:
 - a.** Press **Marker 2 Adj. Level**
 - b.** Turn the general purpose knob to adjust the waveform of marker low level voltage to 0.00 V within ± 50 mV on the oscilloscope display.
- 10.** Press **Save Tweaks** to save the setting.
- 11.** Disconnect the oscilloscope.



Maintenance

Maintenance

This section contains the information needed to do periodic and corrective maintenance on the AWG610 Arbitrary Waveform Generator.

The following subsections are included:

- H **Related Maintenance Procedures** — Provides information relating to various sections discussing maintenance.
- H **Preparation** — Introduction plus general information on preventing damage to internal modules when doing maintenance.
- H **Inspection and Cleaning** — Information and procedures for inspecting the waveform generator and cleaning its external and internal modules.
- H **Removal and Installation Procedures** — Procedures for the removal of defective modules and replacement of new or repaired modules.
- H **Troubleshooting** — Information for isolating failed modules. Included are instructions for operating the waveform generator's internal diagnostic routines and troubleshooting trees. Most of the trees make use of these internal diagnostic routines to speed fault isolation to a module.

Related Maintenance Procedures

The following sections contain information and procedures related to maintenance.

- H The **Operating Information** section covers instructions useful when operating the waveform generator in order to troubleshoot it. It also details the service strategy and lists options for obtaining maintenance service and for replacing failed modules.
- H The **Theory of Operation** section contains a circuit description at the module, or block, level.
- H The **Performance Verification** section contains procedures that may be useful in isolating problems to modules by testing the waveform generator performance.
- H The **Adjustment Procedures** section addresses after repair adjustment and the interval between periodic adjustments. It contains a procedure for adjusting the internal circuits of the waveform generator.
- H The **Diagrams** section contains a block diagram using individual modules as blocks and an interconnection diagram showing connections between the modules.

- H The *Replaceable Mechanical Parts* section, lists all field replaceable modules by part number.

Preparation

Before servicing this product, read the *Safety Summary* and *Introduction* at the front of the manual and the ESD information below.



CAUTION. *Static discharge can damage any semiconductor component in this generator.*

NOTE. *If you are removing a module for service, begin by doing the Access Procedure procedure on page 6-15. By following the instructions in that procedure, you remove the module to be serviced while removing the minimum number of additional modules.*

Preventing ESD

When performing any service which requires internal access to the waveform generator, adhere to the following precautions to avoid damaging internal modules and their components due to electrostatic discharge (ESD).

1. Minimize handling of static-sensitive modules.
2. Transport and store static-sensitive modules in their static protected containers or on a metal rail. Label any package that contains static-sensitive modules.
3. Discharge the static voltage from your body by wearing a grounded antistatic wrist strap while handling these modules. Do service of static-sensitive modules only at a static-free work station.
4. Nothing capable of generating or holding a static charge should be allowed on the work station surface.
5. Handle circuit boards by the edges when possible.
6. Do not slide the modules over any surface.
7. Avoid handling modules in areas that have a floor or work-surface covering capable of generating a static charge.

Susceptibility to ESD Table 6-1 lists the relative susceptibility of various classes of semiconductors. Static voltages of 1 kV to 30 kV are common in unprotected environments.

Table 6-1: Relative susceptibility to static-discharge damage

Semiconductor classes	Relative susceptibility levels ¹
MOS or CMOS microcircuits or discrete circuits, or linear microcircuits with MOS inputs (most sensitive)	1
ECL	2
Schottky signal diodes	3
Schottky TTL	4
High-frequency bipolar transistors	5
JFET	6
Linear microcircuits	7
Low-power Schottky TTL	8
TTL (least sensitive)	9

¹ Voltage equivalent for levels (voltage discharged from a 100 pF capacitor through resistance of 100 ohms):

1 = 100 to 500 V	6 = 600 to 800 V
2 = 200 to 500 V	7 = 400 to 1000 V (est.)
3 = 250 V	8 = 900 V
4 = 500 V	9 = 1200 V
5 = 400 to 600 V	

Inspection and Cleaning

Inspection and Cleaning describes how to inspect for dirt and damage. It also describes how to clean the exterior and interior of the AWG610 Arbitrary Waveform Generators. Inspection and cleaning are done as preventive maintenance. Preventive maintenance, when done regularly, may prevent the waveform generator malfunctions and enhance its reliability.

Preventive maintenance consists of visually inspecting and cleaning the waveform generator and using general care when operating it.

How often to do maintenance depends on the severity of the environment in which the waveform generator is used. A proper time to perform preventive maintenance is just before generator adjustment.

General Care

The cabinet helps keep dust out of the waveform generator and should normally be in place when operating the generator. The generator's front cover protects the front panel and display from dust and damage. Install it when storing or transporting the generator.

Inspection and Cleaning Procedures

Inspect and clean the waveform generator as often as operating conditions require. The collection of dirt on components inside can cause them to overheat and breakdown. (Dirt acts as an insulating blanket, preventing efficient heat dissipation.) Dirt also provides an electrical conduction path that could cause an generator failure, especially under high-humidity conditions.



CAUTION. *Avoid the use of chemical cleaning agents which might damage the plastics used in this waveform generator. Use only deionized water when cleaning the menu buttons or front-panel buttons. Use a ethyl alcohol solution as a cleaner and rinse with deionized water. Before using any other type of cleaner, consult your Tektronix Service Center or representative.*

Inspection — Exterior. Inspect the outside of the generator for damage, wear, and missing parts, using Table 6-2 as a guide. Waveform generators that appear to have been dropped or otherwise abused should be checked thoroughly to verify correct operation and performance. Immediately repair defects that could cause personal injury or cause further generator damage.

Table 6-2: External Inspection Check List

Item	Inspect For	Repair Action
Cabinet, front panel, and cover	Cracks, scratches, deformations, damaged hardware or gaskets.	Repair or replace defective module.
Front-panel knobs	Missing, damaged, or loose knobs.	Repair or replace missing or defective knobs.
Connectors	Broken shells, cracked insulation, and deformed contacts. Dirt in connectors.	Repair or replace defective modules. Clear or wash out dirt.
Carrying handle, bail, cabinet feet.	Correct operation.	Repair or replace defective module.
Accessories	Missing items or parts of items, bent pins, broken or frayed cables, and damaged connectors.	Repair or replace damaged or missing items, frayed cables, and defective modules.

Cleaning Procedure — Exterior. Do the following steps to clean the waveform generator exterior:

1. Remove loose dust on the outside of the generator with a lint free cloth.
2. Remove remaining dirt with a lint free cloth dampened in a general purpose detergent-and-water solution. Do not use abrasive cleaners.
3. Clean the light filter protecting the monitor screen with a lint-free cloth dampened with either ethyl alcohol or, preferably, a gentle, general purpose detergent-and-water solution.



CAUTION. To prevent getting moisture inside the generator during external cleaning, use only enough liquid to dampen the cloth or applicator.

Inspection — Interior. To access the inside of the waveform generator for inspection and cleaning, refer to the *Removal and Installation Procedures* in this section.

Inspect the internal portions of the generator for damage and wear, using Table 6-3 as a guide. Defects found should be repaired immediately.



CAUTION. To prevent damage from electrical arcing, ensure that circuit boards and components are dry before applying power to the waveform generator.

Table 6-3: Internal inspection check list

Item	Inspect for	Repair action
Circuit boards	Loose, broken, or corroded solder connections. Burned circuit boards. Burned, broken, or cracked circuit-run plating.	Remove failed module and replace with a new module.
Resistors	Burned, cracked, broken, blistered condition.	Remove failed module and replace with a new module.
Solder connections	Cold solder or rosin joints.	Re-solder joint and clean with ethyl alcohol.
Capacitors	Damaged or leaking cases. Corroded solder on leads or terminals.	Remove damaged module and replace with a new module from the factory.
Semiconductors	Loosely inserted in sockets. Distorted pins.	Firmly seat loose semiconductors. Remove devices that have distorted pins. Carefully straighten pins (as required to fit the socket), using long-nose pliers, and reinsert firmly. Ensure that straightening action does not crack pins, causing them to break off.
Wiring and cables	Loose plugs or connectors. Burned, broken, or frayed wiring.	Firmly seat connectors. Repair or replace modules with defective wires or cables.
Chassis	Dents, deformations, and damaged hardware.	Straighten, repair, or replace defective hardware.

Cleaning Procedure — Interior. Do the following steps to clean the generator interior:

1. Blow off dust with dry, low-pressure, deionized air (approximately 9 psi).
2. Remove any remaining dust with a lint-free cloth dampened in ethyl alcohol and rinse with warm deionized water. (A cotton-tipped applicator is useful for cleaning in narrow spaces and on circuit boards.)

NOTE. If, after doing steps 1 and 2, a module is clean upon inspection, skip the remaining steps.

3. If steps 1 and 2 do not remove all the dust or dirt, the generator may be spray washed using a solution of ethyl alcohol by doing steps 4 through 8.
4. Gain access to the parts to be cleaned by removing easily accessible shields and panels (see *Removal and Installation Procedures*).
5. Spray wash dirty parts with the ethyl alcohol and wait 60 seconds for the majority of the alcohol to evaporate.
6. Use hot (120_ F to 140_ F) deionized water to thoroughly rinse boards and components.
7. Dry all parts with low-pressure, deionized air.
8. Dry all components and assemblies in an oven or drying compartment using low-temperature (125_ F to 150_ F) circulating air.

Lubrication. There is no periodic lubrication required for this generator.

Removal and Installation Procedures

This subsection contains procedures for removal and installation of all mechanical and electrical modules. Any electrical or mechanical module, assembly, or part listed in the *Replaceable Mechanical Parts* section of this manual is a module.

Preparation — Preparation for Use



WARNING. Before doing this or any other procedure in this manual, read the Safety Summary found at the beginning of this manual. Also, to prevent possible injury to service personnel or damage to this generator's components, read Operating Information: Installation and Preventing ESD in this section.

This subsection contains the following items:

- H This preparatory information that you need to properly do the procedures that follow.
- H List of tools required to remove and disassemble all modules.
- H Three module locator diagrams for finding the External Modules (see Figure 6-2), Outer-Chassis Modules (see Figure 6-3), and Inner-Chassis Modules (see Figure 6-4) in this generator.
- H Procedures for removal and installation of the electrical and mechanical modules.
- H A disassembly procedure for removal of all the major modules from the generator at one time and for reassembly of those modules. A complete disassembly is normally only done when completely cleaning the generator. (Instructions for doing the actual cleaning are found under *Inspection and Cleaning* at the beginning of this section.)
- H Module disassembly procedures.



WARNING. Before doing any procedure in this subsection, disconnect the power cord from the line voltage source. Failure to do so could cause serious injury or death.

List of Modules The *Replaceable Mechanical Parts* section lists all modules.

Summary of Procedures The following procedures are described in the order in which they appear in this section.

- H The *Access Procedure* on page 6-15 directs you to the procedure(s) (if any) that are required to access the module to be serviced, then it directs you to the procedure to remove that module.
- H *Procedures for External Modules* on page 6-16 are procedures for removing modules that do not require internal access to the waveform generator.
- H *Procedures for Outer-Chassis Modules* on page 6-29 are procedures for removing modules which require access to the internal part of the waveform generator but external to the chassis.
- H *Procedures for Inner-Chassis Modules* on page 6-43 are procedures for removing modules which require access to the internal part of the waveform generator and internal to the chassis.

Equipment Required. Most modules in this generator can be removed using a screwdriver with a size #2, Phillips tip. Use this tool whenever a procedure step instructs you to remove or install a screw unless a different size screwdriver is specified in that step. All equipment required to remove and install a module are listed in the first step of each procedure.

Table 6-4: Tools required for module removal

Item no.	Name	Description
1	Screwdriver handle	Accepts Phillips-driver bits
2	#1 Phillips tip	Phillips-driver bit for #1 screw size
3	#2 Phillips tip	Phillips-driver bit for #2 screw size
4	Flat-blade screwdriver	Screwdriver for removing standard-headed screws
5	Needle-Nose Pliers	Standard tool
6	Nutdriver, $\frac{1}{8}$ inch	Standard tool
7	Nutdriver, 5 mm	Standard tool
8	Nutdriver, 7 mm	Standard tool
9	Retaining Ring Pliers	Standard tool
10	Angle-Tip Tweezers	Standard tool
11	Soldering Iron	Standard tool
12	Pliers	Standard tool

Table 6-4: Tools required for module removal (Cont.)

Item no.	Name	Description
13	Solder Wick	Standard tool
14	Adhesive	TRA-CON: Tra-Bond #BA-2114

Instrument Orientation

The procedures refer to “front,” “right,” “top,” etc. of the waveform generator. Figure 6-1 shows how the sides are referenced.

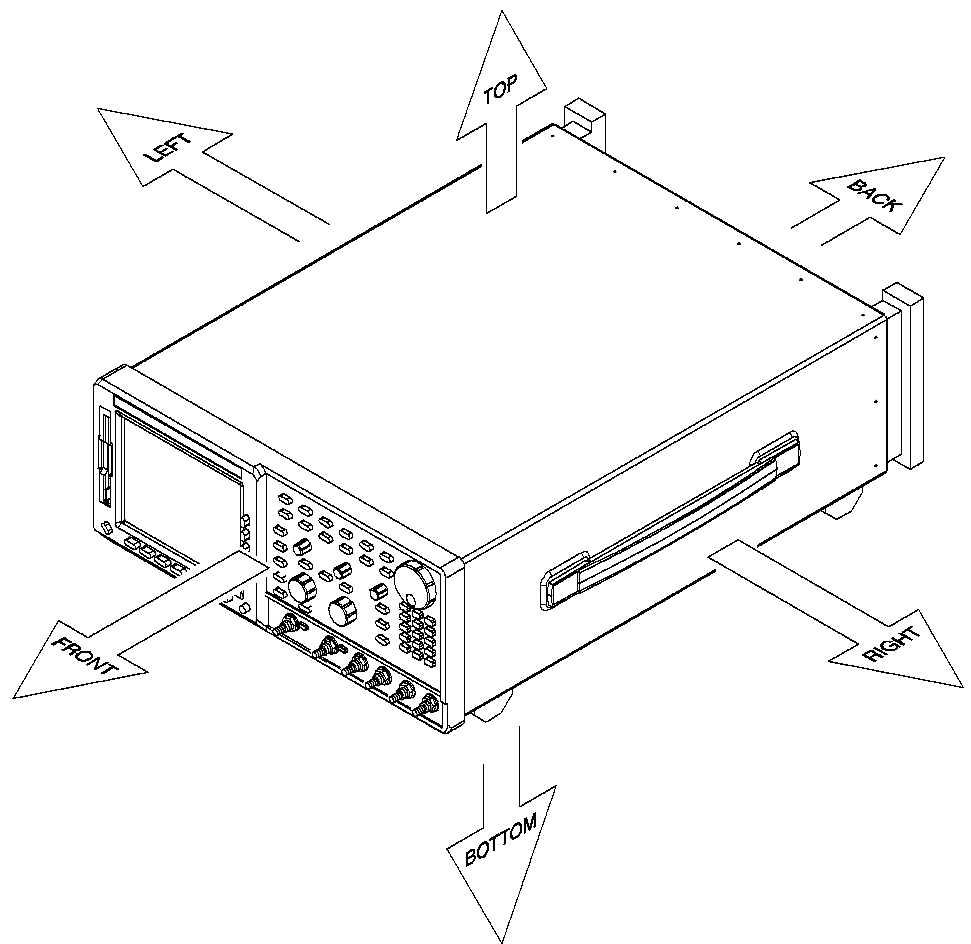

Figure 6-1: Instrument orientation

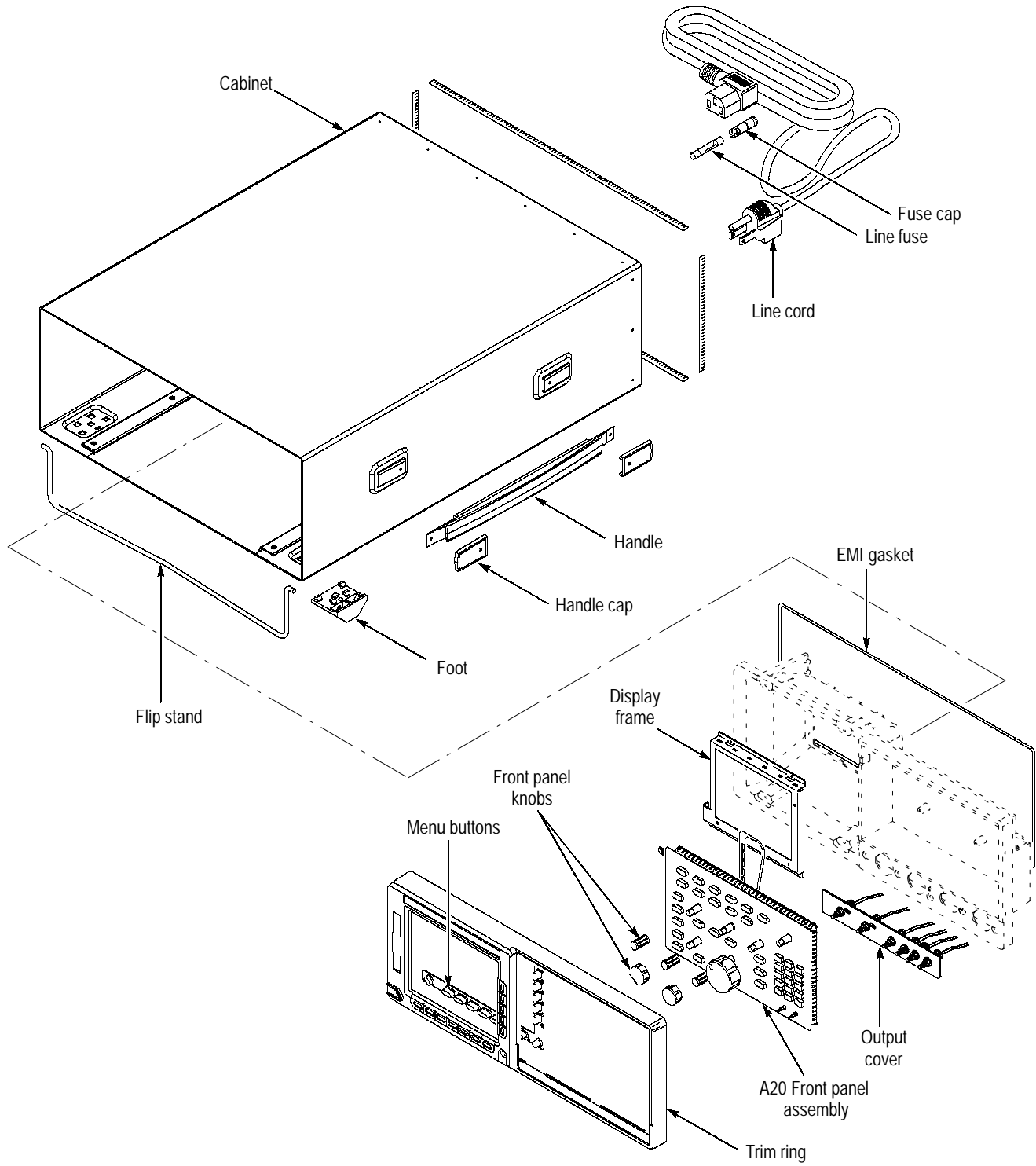

Figure 6-2: External modules

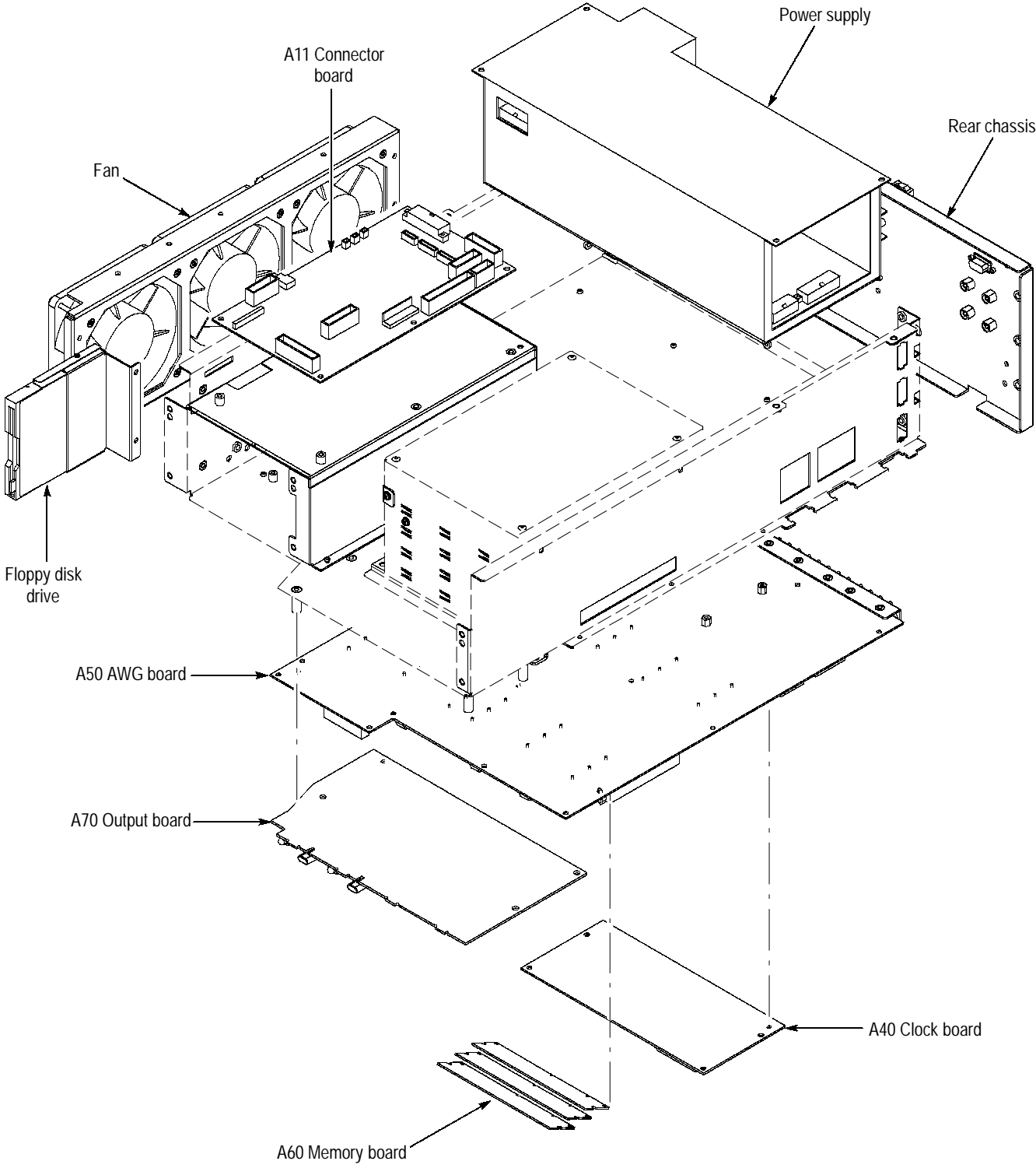

Figure 6-3: Outer-chassis modules

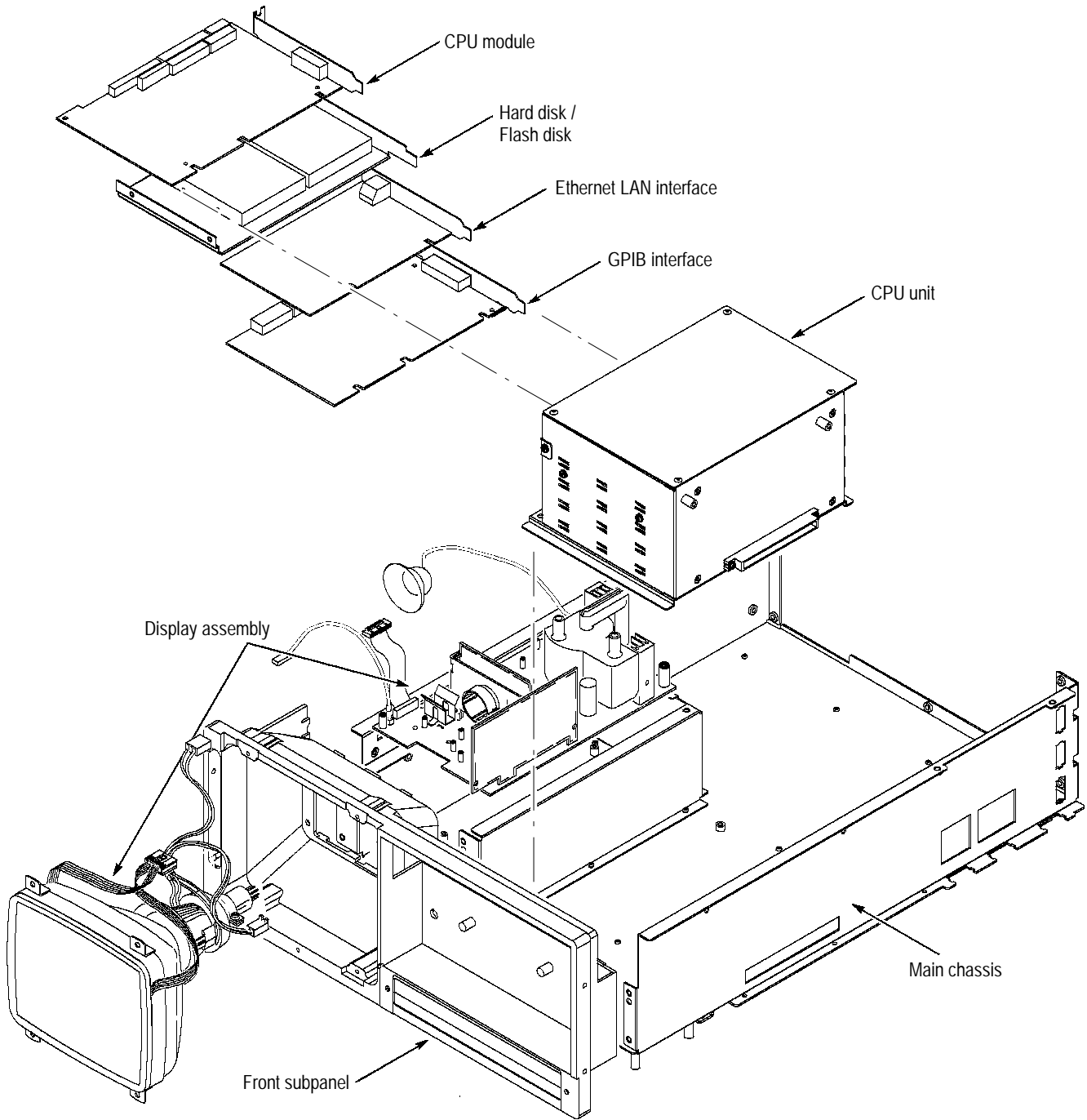

Figure 6-4: Inner-chassis modules

Access Procedure

Begin with this procedure when you have identified a module to be removed for service.

1. Find the module to be removed in Figures 6-2 through 6-4.
The title of the figure indicates whether the module is an external, outer-chassis mounted, or inner-chassis mounted part.
2. If the module is externally mounted and no internal access is required; remove the module. Locate the necessary in the *Procedures for External Modules* on page 6-16.
3. If the module is an outer- or inner-chassis module and access is required inside of the instrument; do the *Line Fuse and Line Cord* procedure then do the *Cabinet* procedure. Both procedures are in the *Procedures for External Modules* subsection.
4. After completing those procedures, return to this procedure and continue with step 5.
5. If the module is an outer-chassis module, remove it.
 - a. If removing the attenuator or display-frame assembly, first do the procedure *Trim Ring, Menu Buttons, and Output Panel*, found under *Procedures for External Modules* (page 6-16).
 - b. Find and do the procedure for the module to be removed under *Procedures for Outer-Chassis Modules*, on page 6-29.
6. If the module is an inner-chassis module, access the inner-chassis.
 - a. If removing the display tube, display-driver board, or the front subpanel, first do the procedure for the *Trim Ring, Menu Buttons, and Output Panel*, found under *Procedures for External Modules*. Also remove the display-frame assembly found under *Procedures for External Modules*, on page 6-16.
 - b. If removing the front subpanel, do the *A20 Front-Panel Assembly* also found under *Procedures for External Modules*.
 - c. Do the procedure *A11 Connector Board* found under *Procedures for Outer-Chassis Modules*, page 6-29.
 - d. Find and do the procedure for the module to be removed under *Procedures for Inner-Chassis Modules*, page 6-43.
7. Install all modules previously removed. Read the instructions found at the end of the procedure that removes the module to be serviced. These instructions will guide you in installing all modules previously removed.

Procedures for External Modules

Do the *Access Procedure* on page 6-15, before doing any procedure in this collection.

The following procedures are listed in order presented.

- H *Front-Panel Knobs*
- H *Line Fuse and Line Cord*
- H *EMI Gaskets*
- H *Cabinet*
- H *Trim Ring, Menu Buttons, and Output Panel*
- H *A20 Front-Panel Assembly*
- H *Display Frame Assembly*
- H *Cabinet Modules*

Front Panel Knobs

You will need an angled-tip tweezers (Item 10).

1. Find the knob(s) to be removed on the front panel.
2. Orient the waveform generator so its bottom is down on the work surface and its front is facing you.
3. Remove the knob(s) by pulling it straight out from the front panel slightly to create some clearance between the base of the knob and the front panel. Insert the tweezers between the knob and front panel and use them to remove the knob. See Figure 6-5.
4. To install, align knob to shaft and push it in until it snaps into place.

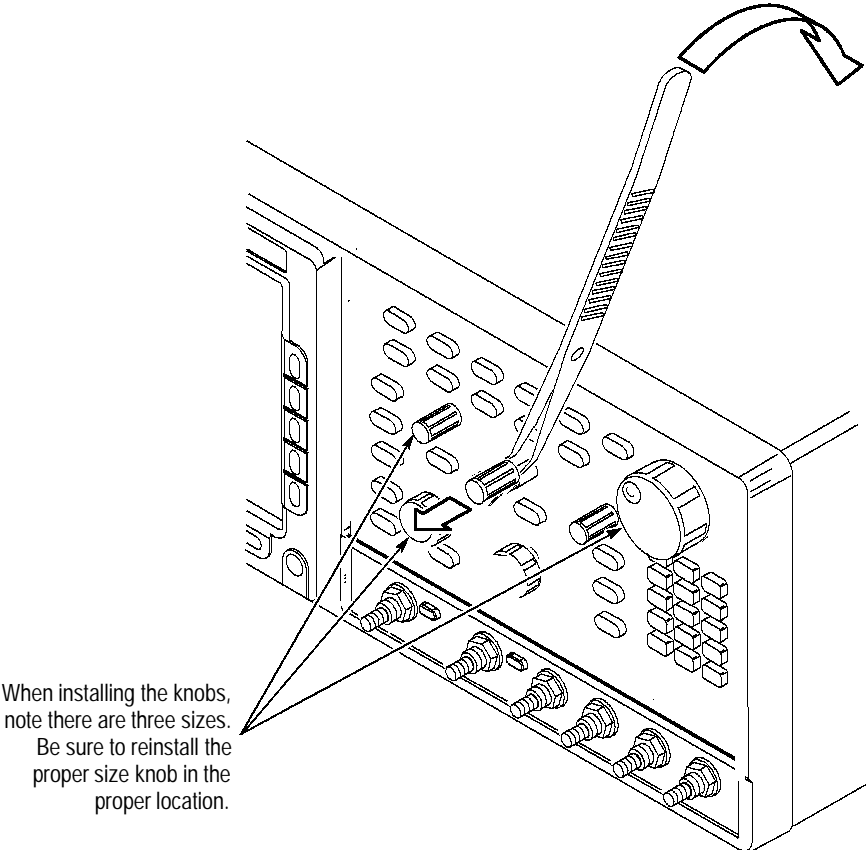

Figure 6-5: Knob removal

Line Fuse and Line Cord

You will need a flat-blade screwdriver (Item 4). Locate the line fuse and line cord in Figure 6-2.

1. Orient the generator so its bottom is down on the work surface and its rear is facing you. If you are servicing the line fuse, do the next step; if you are servicing the line cord, skip to step 3.
2. Find the fuse cap on the rear panel. See Figure 6-6. Remove the fuse cap by turning it counterclockwise using a flat-blade screwdriver, and remove the line fuse.
3. Find the line cord on the rear cover. See Figure 6-6. Pull the line cord to complete the removal. Reverse procedure to install.
4. Do in reverse steps 2 and 3 to install the line cord and then the line fuse.

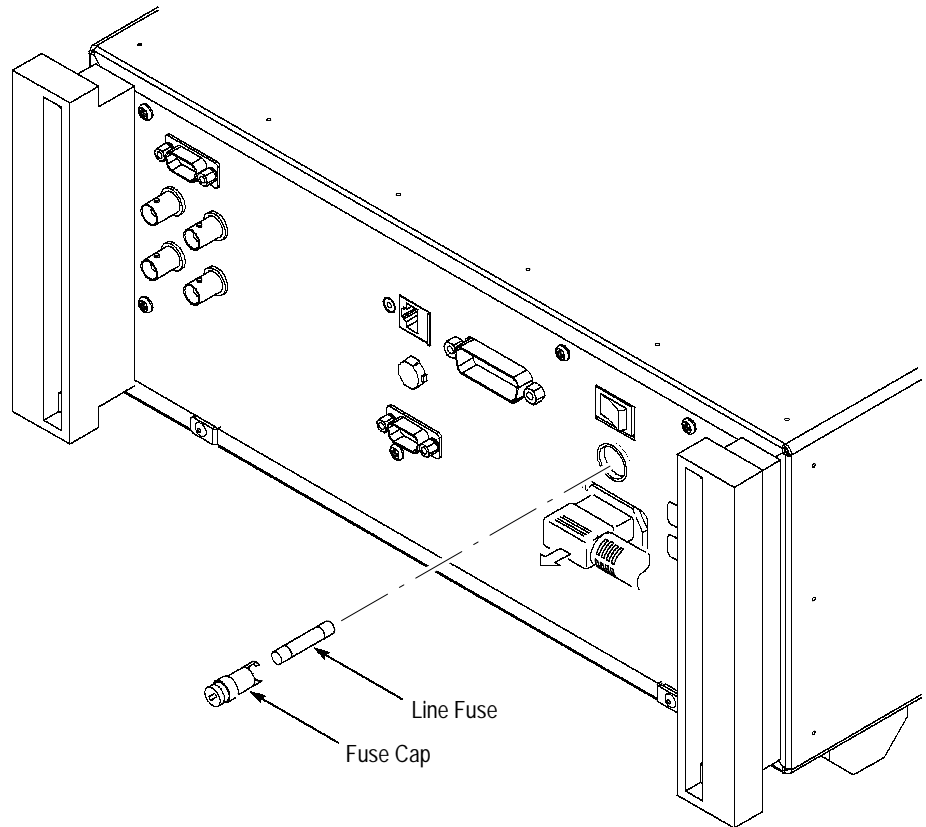

Figure 6-6: Line fuse and line cord removal

EMI Gaskets See cabinet procedure below.

Cabinet You will need a screwdriver with a size Phillips #2 tip (Items 1 and 3).

1. Make sure the generator's front cover (optional accessory) is installed; if it's not, install it by snapping its edges over the trim ring.
2. Locate the cabinet in Figure 6-2.
3. Orient the generator so its face is down with its front cover on the work surface and its bottom facing you.
4. Unplug the line cord from its receptacle at the rear cover.
5. Remove the six screws at the rear of the cabinet that are securing the two feet.
6. Grasp the left and right edges at the rear of the cabinet.
7. Pull upward to slide the cabinet off the generator. Take care not to bind or snag the cabinet on the generator's internal cabling as you remove it.

NOTE. Do not do steps 8 through 13 to remove the EMI gasket(s) unless they must be replaced due to damage. If you are not replacing those gaskets, skip to step 14.

When installing EMI gaskets and/or the generator cabinet, carefully follow the instructions given. Unless they are performed properly, the generator may not meet its emissions requirements (EMI).

8. Locate the EMI gaskets to be removed in Figure 6-2.

You will need a pair of needle-nose pliers (Item 6).

9. Look for the point where the ends of the gasket touch in the channel at the rear edge of the cabinet.
10. Use a pair of needle-nose pliers to pry up one of the ends.
11. Grasp the EMI gasket, and gently pull it out of its channel.
12. Repeat substeps 9 through 11 to remove the gasket from its channel on the front casting.
13. To install, press each EMI gasket back into its groove at the rear edge of the cabinet or front casting. Make sure the ends of the gasket touch, but do not overlap, when installing. Cut off excess length if required to prevent overlap.
14. To install the cabinet, do steps 3 and 4 in reverse order.

- a.** Take care not to bind or snag the cabinet on internal cabling; redress cables if necessary.
- b.** When sliding the cabinet, be sure that the front edge of the cabinet aligns with the groove containing the EMI shield on the front casting.
- c.** Be sure that the ridge around the rear chassis slides into the groove containing a second EMI cable on the rear of the cabinet.
- d.** When installing the four screws at the rear panel, tighten them to 16 foot-lbs torque.
- e.** See the procedure *Line Fuse and Line Cord* to install the line cord.

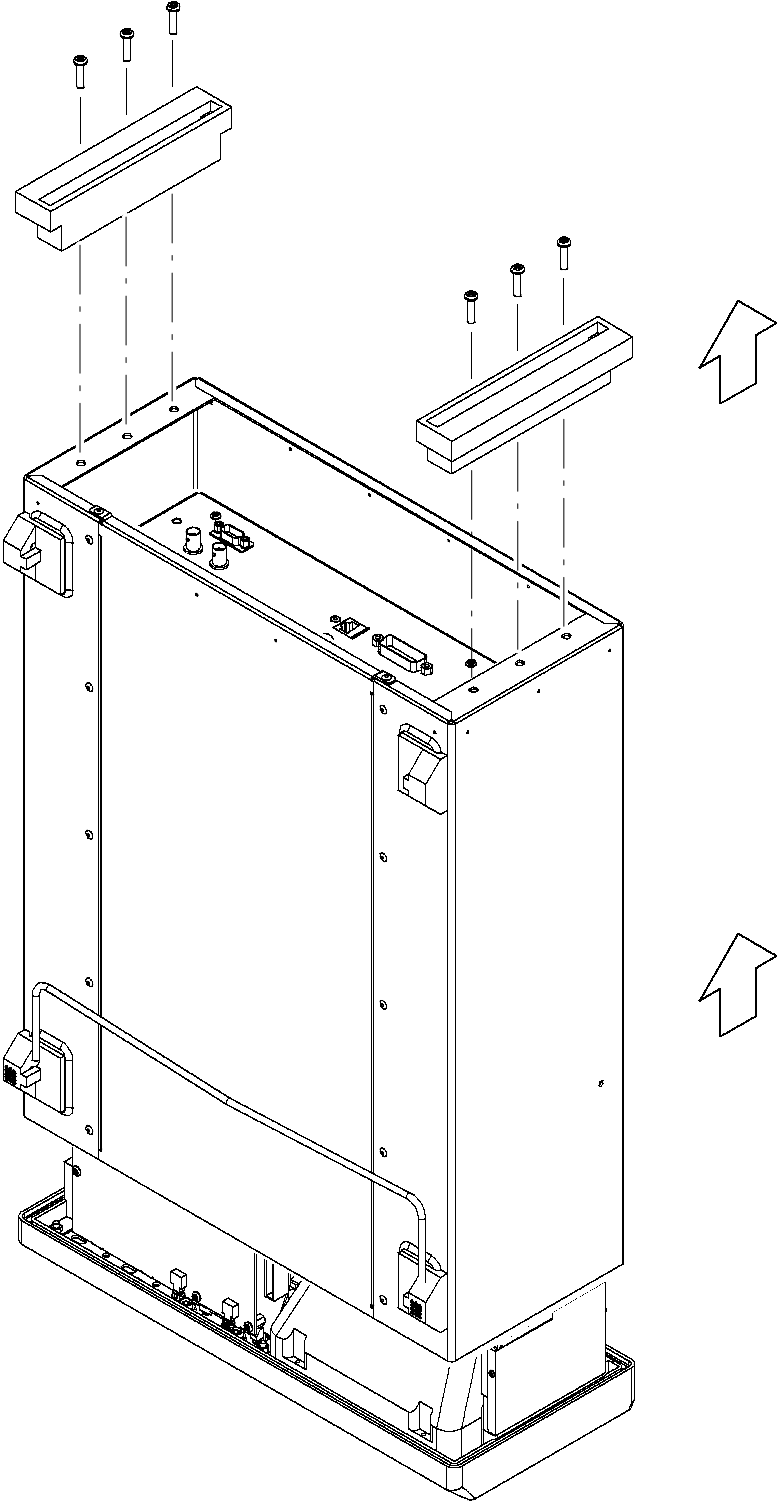

Figure 6-7: Cabinet removal

**Trim Ring, Menu Buttons,
and Output Panel**

No tools are needed for this procedure.

1. Locate the modules to be removed in Figure 6-2.
2. Orient the generator so its rear is down on the work surface and its bottom is facing you.
3. Remove the front cover by grasping the front cover by its left and right edges and snap it off of the front subpanel. When installing, align and snap back on. See Figure 6-8.

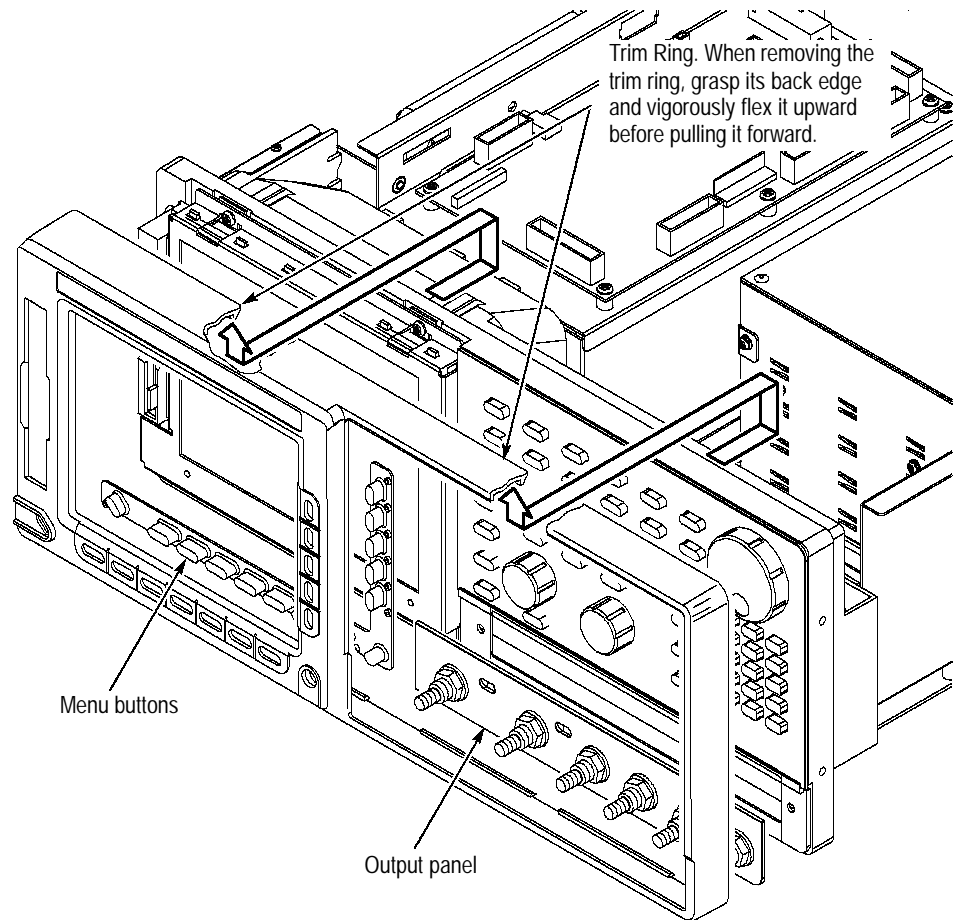

Figure 6-8: Trim ring, menu buttons, and output panel removal

NOTE. Do not touch the carbon contact points on the menu buttons installed in the trim ring. Also, do not touch the contacts on the flex circuit exposed when you remove the trim ring.

4. Remove the trim ring by grasping its top edge and pry it up and lift it forward to snap it off of the front subpanel. If servicing the menu buttons, lift them out of the trim ring. When installing, insert the menu buttons, align the trim ring to the front subpanel and press it back on.
5. Remove the output panel by gently prying, with your fingers, the snap-off/snap-on output panel away from the front subpanel. When installing, use your hands to press it back on.
6. To install the output panel, menu buttons, and trim ring, do steps 3-5 in reverse.

A20 Front-Panel Assembly

This procedure includes removal and installation instructions for the front panel and front panel buttons. Unless either of those modules are being serviced, do not do step 4 on page 6-24.

You will need a screwdriver with a size Phillips #2 tip (Items 1 and 3).

1. Locate the modules to be removed in Figure 6-2.
2. Do the procedure *Trim Ring, Menu Buttons, and Output Panel*, steps 1-5, immediately preceding this procedure.
3. Orient the waveform generator so its bottom is down on the work surface and its front is facing you.
4. Remove the front-panel assembly out of the front subpanel by lifting the assembly until you can reach the interconnect cable connecting it to the Connector board.
5. Disconnect that cable at J121 of the Connector board. Disconnect the flex-board connector at P3 of the Front-Panel assembly. (The flex board is part of the display-frame assembly). See Figure 6-9.
6. Lift the Front-Panel assembly out of the front subpanel to complete the assembly.

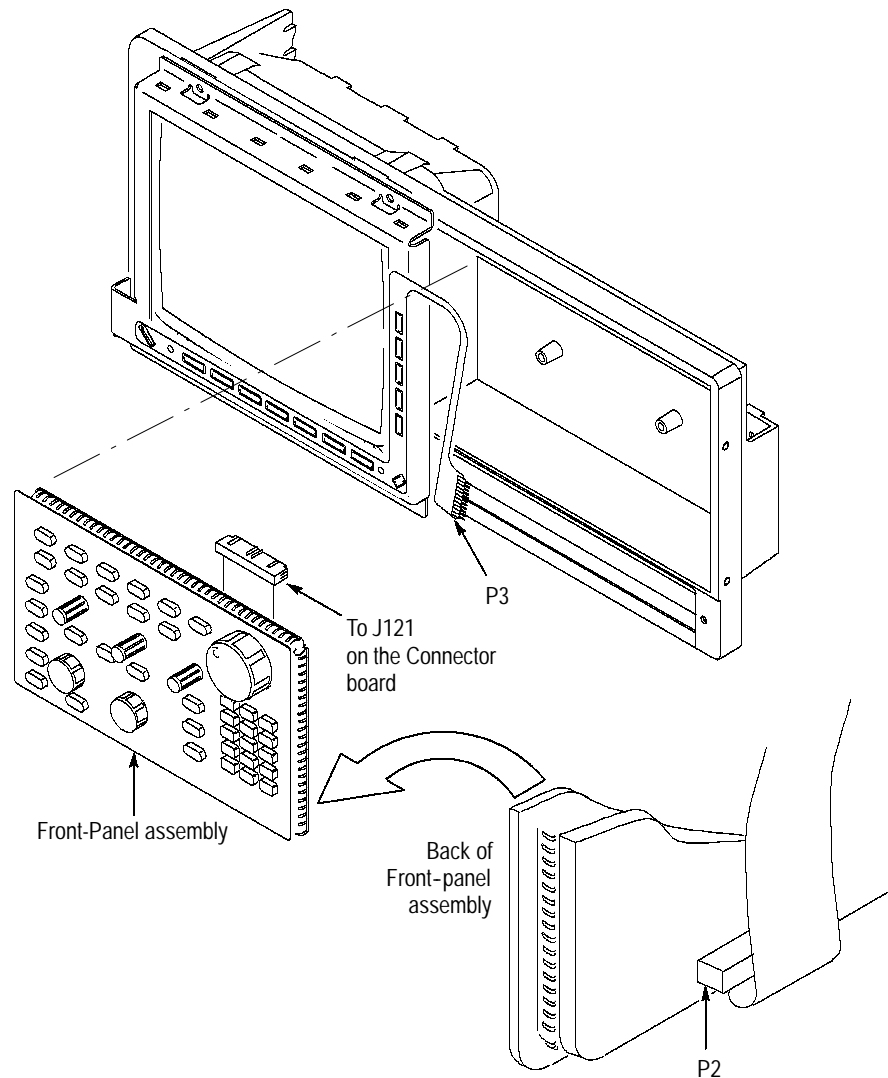

Figure 6-9: A20 Front-Panel assembly removal

If the front panel or the front-panel buttons are to be serviced, do the following steps:

7. Remove the front-panel control knobs from the front-panel assembly using the method described in *Front-Panel Knobs* on page 6-16.
8. Remove the eight screws mounting the front-panel board to the front panel.
9. Hand disassemble the front-panel assembly components using Figure 6-10 as a guide. Do this procedure in reverse to reassemble using Figure 6-10 as a guide.

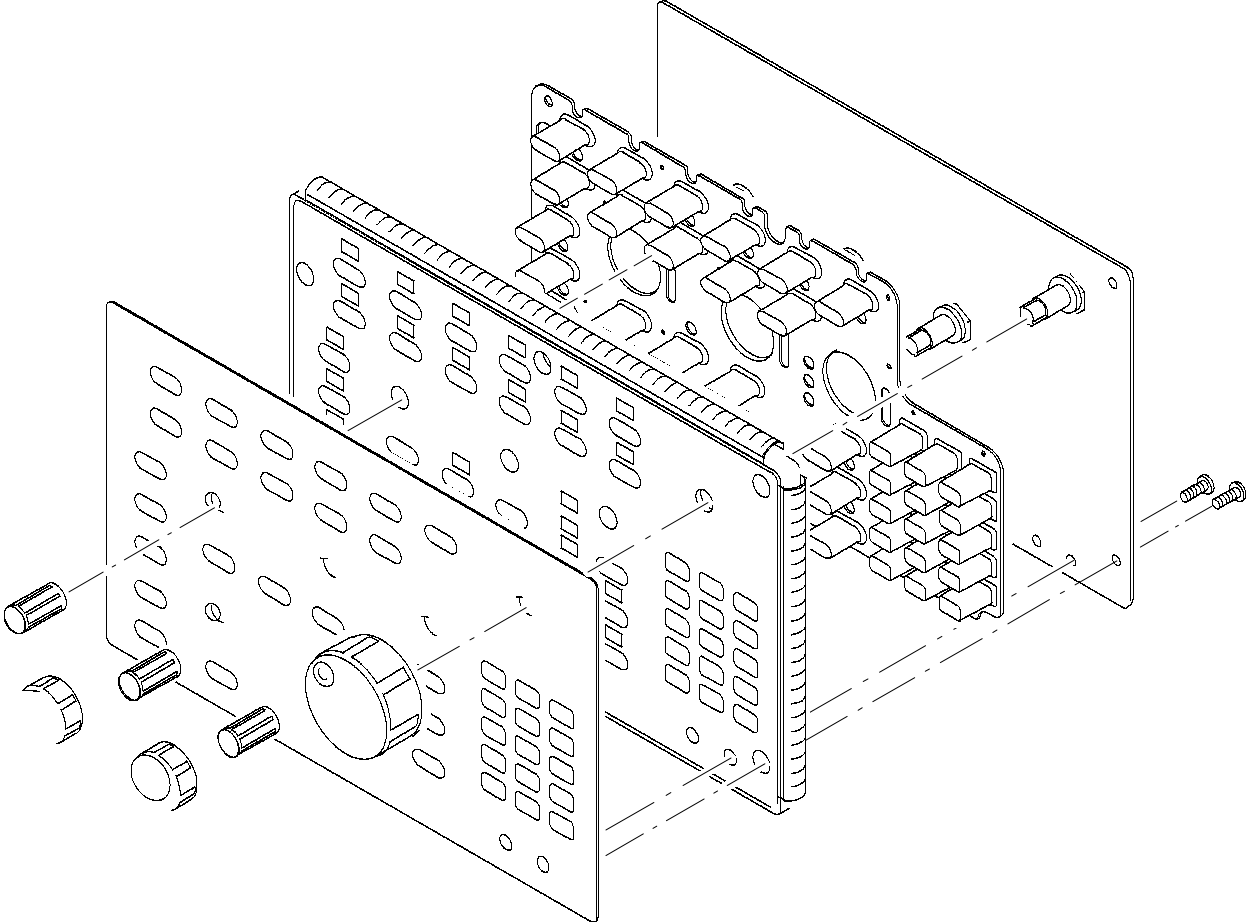

Figure 6-10: Disassembly of Front-Panel assembly

10. To install, reverse this procedure.

Display-Frame Assembly

You will need a screwdriver with a size Phillips #2 tip (Items 1 and 3).

- 1.** Locate the modules to be removed in Figure 6-2, page 6-12.
- 2.** Orient the waveform generator so its bottom is down on the work surface and its front is facing you.
- 3.** Do the procedure *Trim Ring, Menu Buttons, and Output Panel* (page 6-22) to remove the front cover and trim ring.
- 4.** Lift the front-panel assembly out of the front subpanel until you can reach P2 on the assembly. Disconnect the flex cable coming from the display-frame assembly at P3 of the front-panel assembly.
- 5.** Do the procedure *Floppy Disk* (page 6-30) to remove the floppy disk drive.
- 6.** Remove the three screws securing the display-frame assembly to the front subpanel and remove that assembly.
- 7.** To install, reverse this procedure.

Cabinet Modules

You will need a pair of needle-nose pliers (Item 5).

- 1.** Locate the modules to be removed in Figure 6-2
- 2.** Orient the waveform generator so the left side is down on the work surface and its handle is facing upwards.

- 3.** Remove the handle by inserting the tips of a pair of needle-nose pliers (Item 5) into the hole of either handle cap. Push and hold to depress the handle release.
- 4.** While holding the handle release, pull it out of the slot in the handle cap. Repeat procedure to remove the handle from the other handle cap.
- 5.** To install, reverse this procedure.
- 6.** Remove the handle caps by inserting the retaining ring pliers (Item 9) into the opening created in the handle cap when you removed the handle.
- 7.** While using the pliers to expand the handle cap outward, grasp it and snap it off.
- 8.** Repeat procedure to remove the remaining cap as needed; push the cap(s) back on to install.
- 9.** Remove the flip stand by grasping the flip stand by both sides near where it joins each flip stand foot. Now compress the flip stand until the flip stand ends clear the flip stand feet to complete the removal.
- 10.** To remove the flip stand foot or feet, do the *Cabinet* procedure (page 6-19) to gain access to inside of the cabinet.
- 11.** Working from inside the cabinet, push the two retainers to release the flip stand foot you wish to remove and lift it away from the outside of the cabinet.
- 12.** Repeat this procedure to remove as many of the remaining feet as needed. Insert the two retainers back in their slots in the cabinet and snap any flip stand foot, previously removed, into place.
- 13.** To install, reverse this procedure.

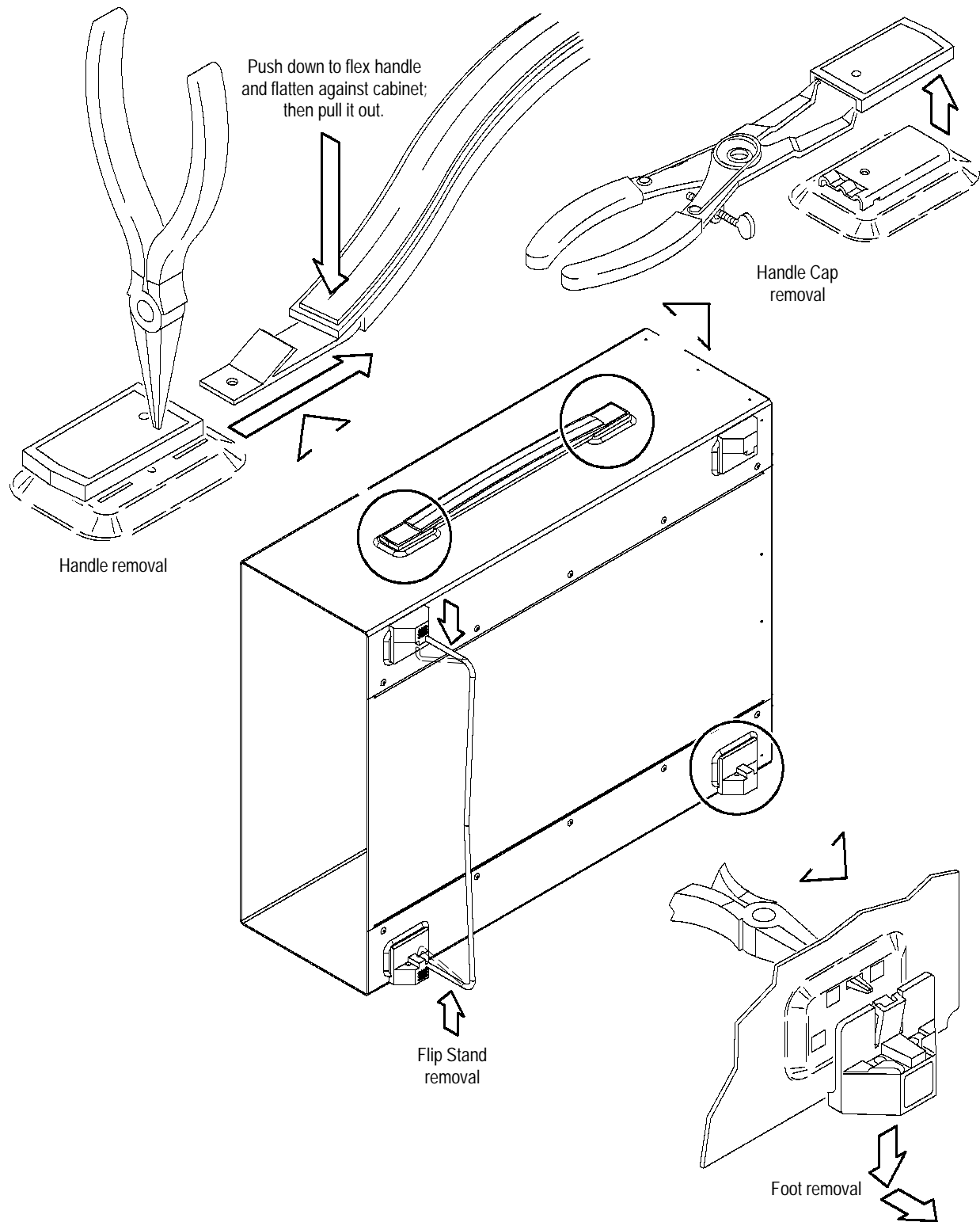

Figure 6-11: Cabinet modules removal

Procedures for Outer-Chassis Modules

You should have completed the *Access Procedure* before doing any procedure in this collection. This section describes removal/installation procedures for the following modules:

- H *Fan*
- H *Floppy disk*
- H *PS100 Low Voltage Power Supply*
- H *A11 Connector Board*
- H *A60 Memory Board*
- H *A75 Noise Generator Board*
- H *A70 Output Board*
- H *A40 Clock Board*
- H *A50 AWG Board*
- H *Rear Chassis*

Fan You will need a screwdriver with a size #2 Phillips tip (Items 1 and 3).

1. Locate the fan in Figure 6-3 on page 6-13.
2. Orient the waveform generator so its bottom is down on the work surface and its left side is facing you.
3. Unplug three fan power cables from the Connector board at J910, J911, and J912.
4. Remove the four screws that are securing the fan bracket to the main chassis, and lift the fans away from the chassis. When removing each fan, remove the four screws securing the fan to the bracket, and lift it away from the bracket.
5. To install, do the steps in reverse order. Refer to the *Cabinet* procedure, on page 6-19, to complete assembly of the generator.

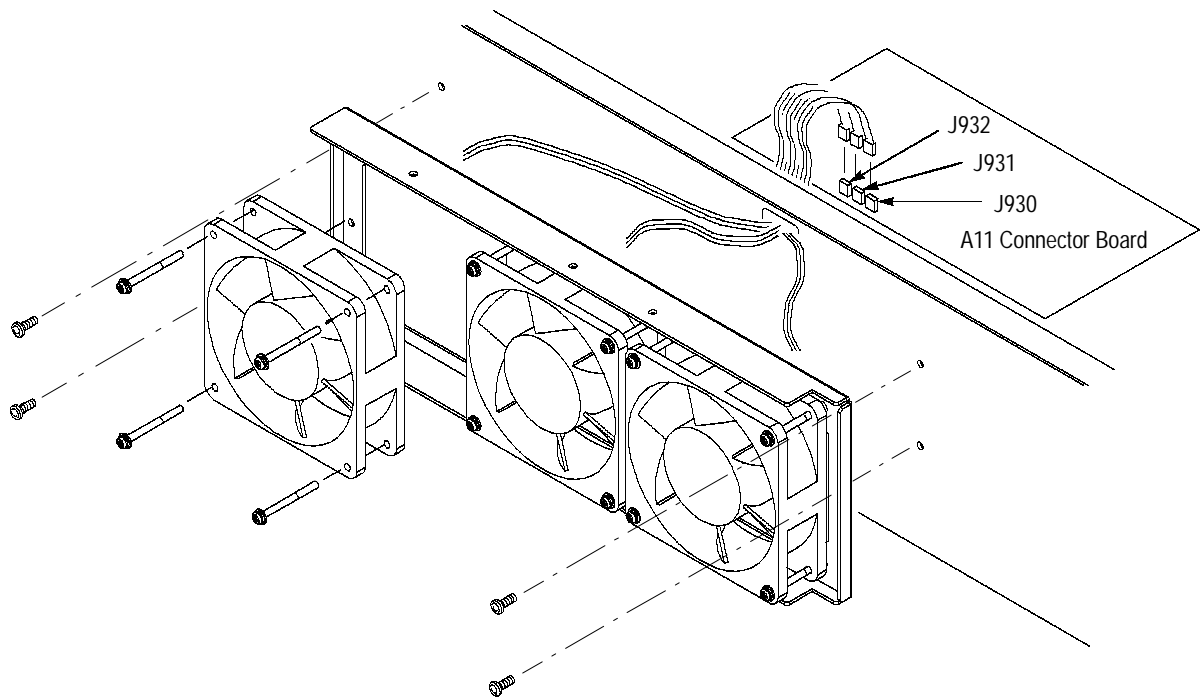

Figure 6-12: Fan removal

Floppy disk

You will need a screwdriver with a size #2 Phillips tip (Items 1 and 3), and if removing the disk drive main body, you will need a #1 Phillips head (Item 2).

1. Locate the modules to be removed, including those listed under *Additional Modules Removed* in Figure 6-3, page 6-13.
2. Do the procedure *Trim Ring, Menu Buttons, and Output Panel* on page 6-22.
3. Orient the waveform generator so its top is down on the work surface and its left side is facing you.

4. Remove the floppy disk drive using Figure 6-13 as a guide.
5. Unplug the J124 floppy driver connector (ribbon interconnect cable) that connects the disk drive to the A11 Connector board.
6. Use the screwdriver with #2 Phillips tip to remove the two screws securing the floppy disk bracket to the main chassis, and lift it away from the chassis. When removing the disk drive main body, use the screwdriver with #1 Phillips tip to remove the two screws securing the drive to the bracket, then pull out the disk drive.

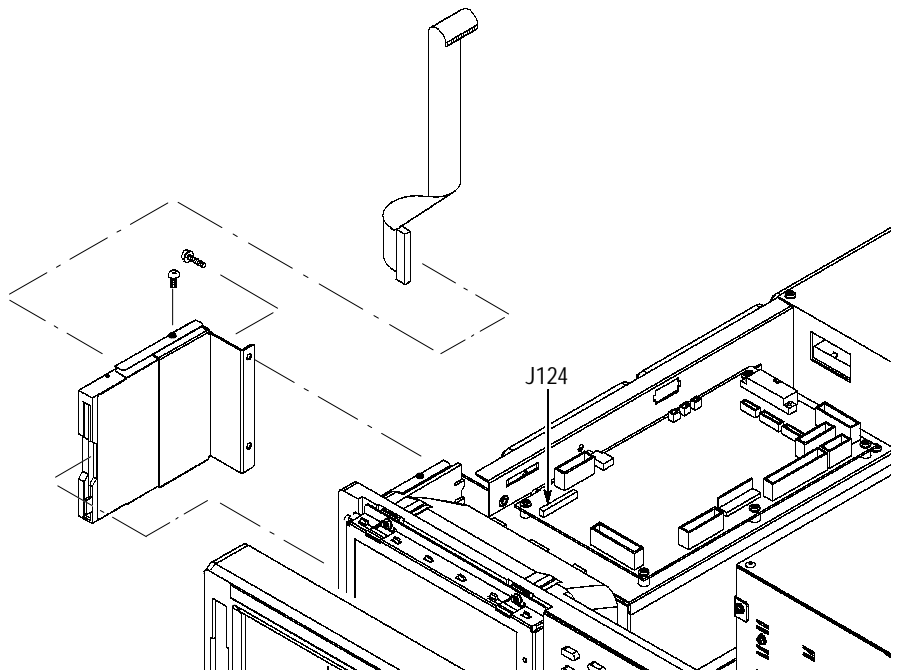

Figure 6-13: Floppy disk removal

7. To install, do this procedure in reverse order. Then refer to the *Cabinet* procedure on page 6-19 to complete assembly of the generator.

PS100 Low Voltage Power Supply

You will need a screwdriver with a size #2 Phillips tip (Items 1 and 3).

1. Locate the fan in Figure 6-3, page 6-13.
2. Orient the waveform generator so its bottom is down on the work surface and its right side is facing you.

3. To remove the low-voltage power supply unplug three power cables from J1, J2, and J3 on the A11 Connector board. See Figure 6-14.
4. Remove the two screws from the rear of the generator that mount the low-voltage power supply to the rear chassis.
5. Remove the four screws from the top of the generator that mount the supply to the main chassis. Then remove the screw securing the ground lead to the main chassis.
6. Lift the module up out of the generator to complete removal.

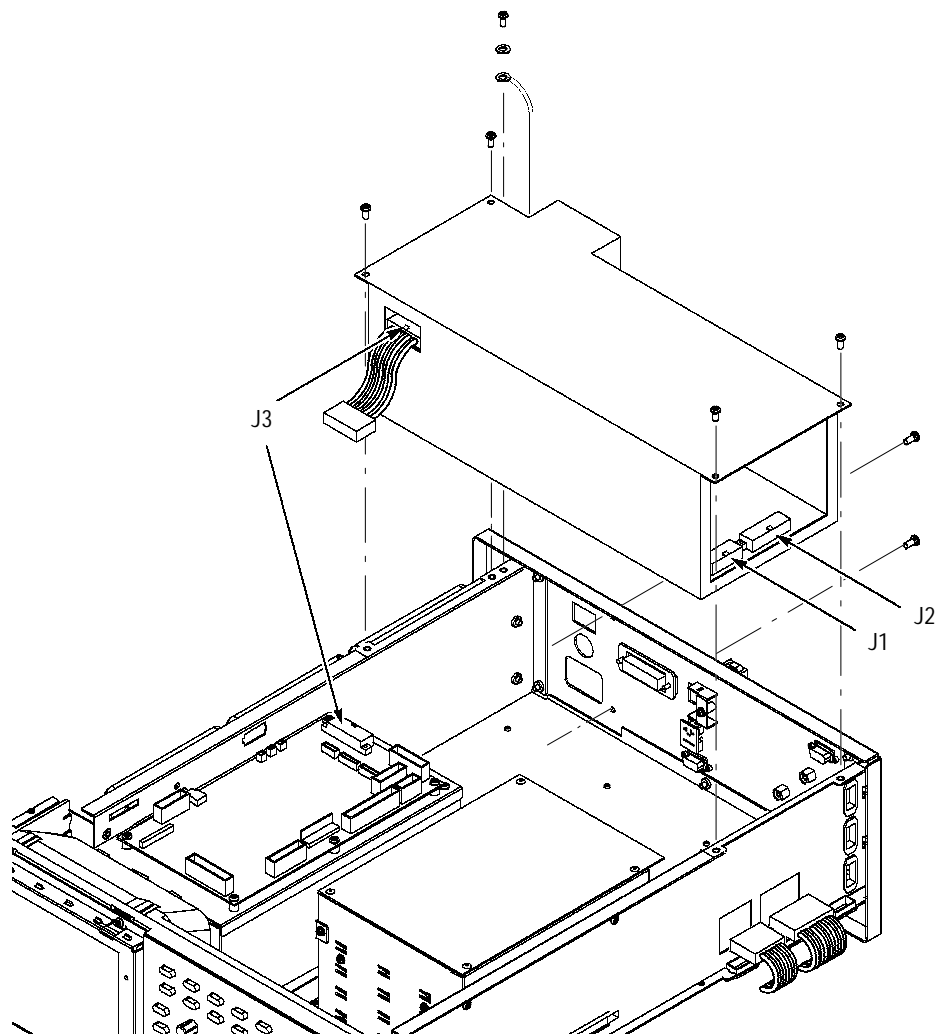

Figure 6-14: Power supply module removal

7. To install, do this procedure in reverse order then refer to the *Cabinet* procedure, on page 6-19 to complete assembly of the generator.

A11 Connector Board

You will need a screwdriver with a size #2 Phillips tip (Items 1 and 3).

1. Locate the modules to be removed in Figure 6-3, page 6-13.
2. Orient the waveform generator so its bottom is down on the work surface and its front is facing you.
3. To disconnect the *A11 Connector Board*, disconnect the following cables and connectors. See Figure 6-15 as a guide.
 - H Three fan's power cables at J930, J931, and J932.
 - H The cable from the low-voltage power supply at J3.
 - H The interconnect cables from CPU board at J110, J112, and J113.
 - H The interconnect cables to the Monitor Out at J127 and the A90 Key board at J128.
 - H The interconnect cable from the A30 GPIB board at J115.
 - H The interconnect cable from the Back Plane at J122.
 - H The cables from the A20 Front Panel board at J121.
 - H J125 video signal connector and J124 floppy driver connector.
4. Use a screwdriver with a size #2 Phillips tip, to remove the five screws that attach the A11 Connector board to the chassis.
5. Lift the board up and away from the chassis to complete the removal.
6. To install, do this procedure in reverse order then refer to the *Cabinet* procedure, on page 6-19 to complete assembly of the generator.

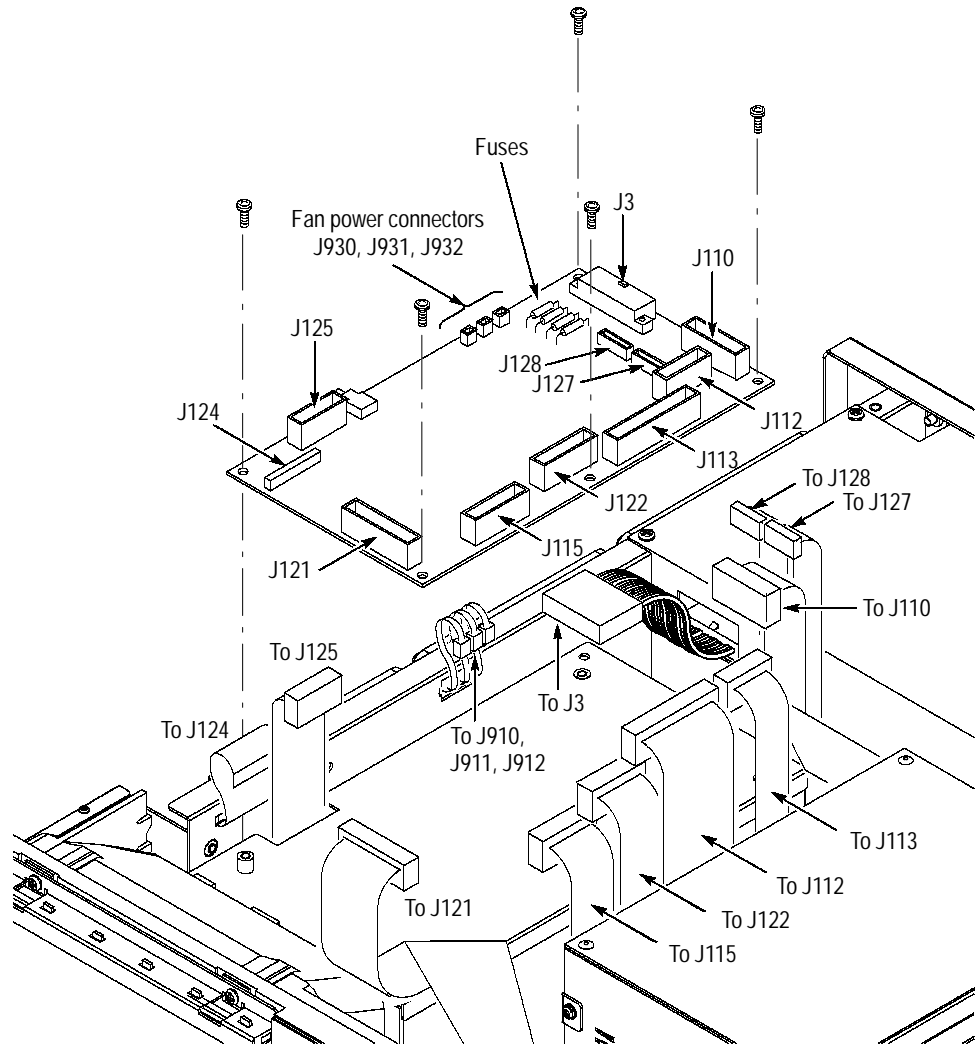

Figure 6-15: A11 Connector board removal

A60 Memory Board

You will need an angled-tip tweezers (Item 10).

1. Locate the modules to be removed in Figure 6-3, page 6-13.
2. Orient the waveform generator so its top is down on the work surface and its right side is facing you.

3. To remove the *A60 Memory Board*, release the retainer latches securing the memory boards to the A50 AWG board. See Figure 6-16. Using the tweezers, pinch the tab of the retainer out of the hole of the memory board. Then, insert the tweezers' tip into the hole of the retainer to slide it out.
4. Open the lever on one side of the connector, and lift out the memory board.
5. Repeat steps 3 and 4 to remove the other memory boards.

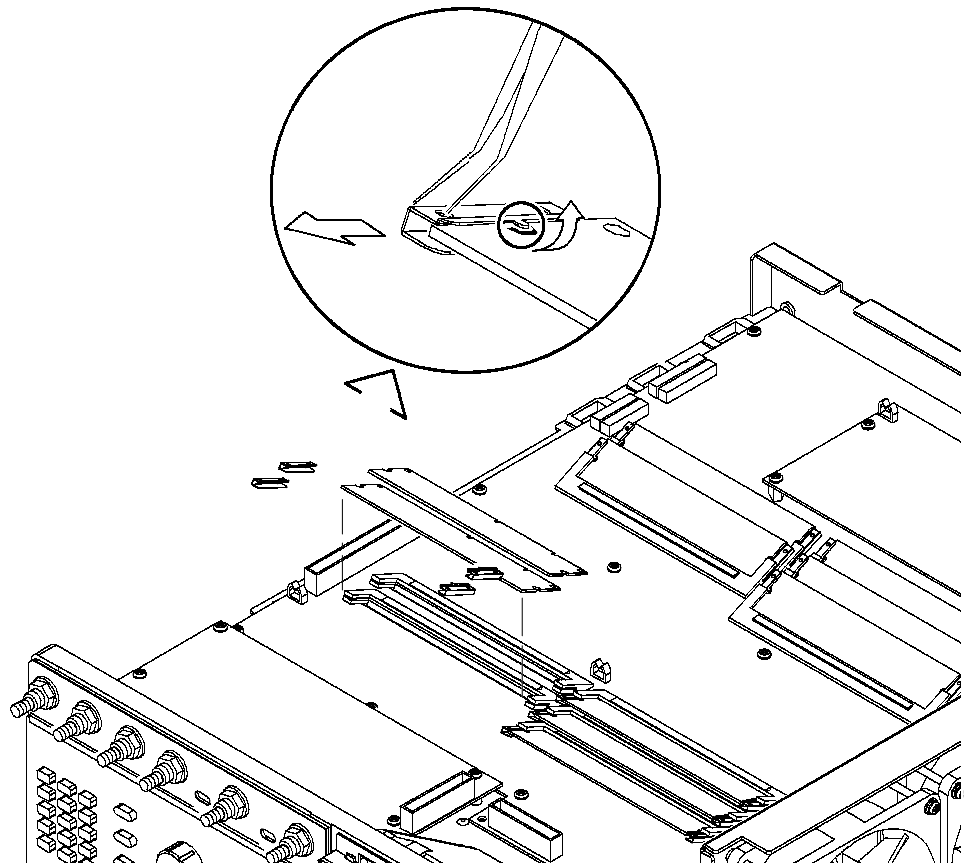

Figure 6-16: A60 Memory Board removal

6. To install each memory board, reverse steps 3 and 4.

A70 Output Board

You will need a screwdriver with a size #2 Phillips tip (Items 1 and 3).

1. Locate the modules to be removed in Figure 6-3, page 6-13.

2. Do the A75 Noise Generator Board procedure that precedes this procedure to remove the interconnect cables.
3. Orient the waveform generator so its top is down on the work surface and its front is facing you.
4. Remove *A70 Output Board* using Figure 6-17 as a guide.
5. Unplug the following cables and connector:
 - H The coax cables from ADD INPUT at J300, NOISE IN at J310, CH 1 OUTPUT at J195, and CH 2 (AWG610)/CH 1 INVERT (AWG610) OUTPUT at J295
 - H The interconnect cables from the A50 AWG board at J100, J102, J200, and J202
 - H The cable connector from the A50 AWG board at J700
6. Remove the four screws attaching the Output board to the main chassis.
7. Lift the Output board up away from the main chassis to complete the removal.

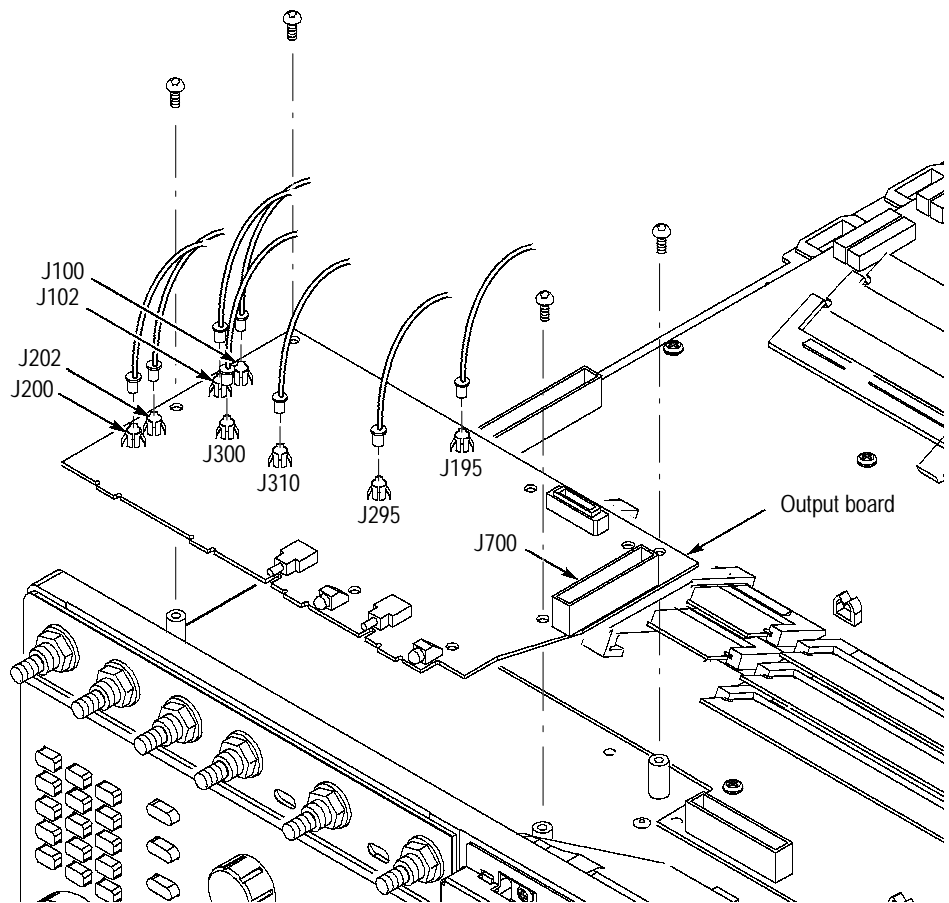

Figure 6-17: A75 Noise Generator Board and A70 Output Board removal

8. To install, do this procedure in reverse order then refer to the procedure *Cabinet* (page 6-19) to complete the assembly.

A40 Clock Board

You will need a screwdriver with a size #2 Phillips tip (Items 1 and 3).

1. Locate the modules to be removed in Figure 6-3, page 6-3.
2. Orient the waveform generator so its top is down on the work surface and its rear is facing you.

3. Remove the *A40 Clock Board*. using Figure 6-18 as a guide.
 - a. Unplug two interconnect cables at J41, J130, and J150 on the A40 Clock board.
 - b. Remove the four screws attaching the Clock board to the AWG board.
 - c. Disconnect the Clock board from the AWG board, then lift it up away to complete the removal.

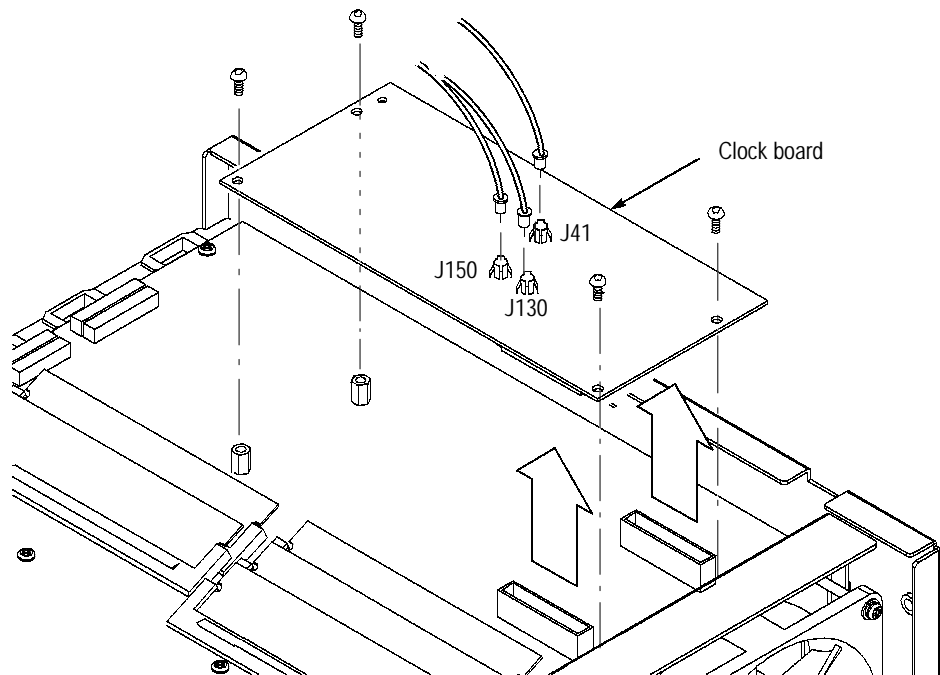

Figure 6-18: A40 Clock Board removal

4. To install, do the procedure in reverse order.

A50 AWG Board

You will need a screwdriver with a size #2 Phillips tip (Items 1 and 3).

1. Locate the modules to be removed in Figure 6-3, page 6-13.
2. Do the procedure *A70 Output Board* that precedes this procedure to remove the Output board.
3. Orient the waveform generator so its left side is down on the work surface and its rear is facing you.
4. Remove the *A50 AWG Board*. using Figure 6-19 as a guide.

5. Unplug the following cables and connectors:
 - H Two connectors J1 and J2 on the low-voltage power supply.
 - H The cable from EVENT INPUT at J200 on the AWG Board.
 - H The coax cable to 1/4 CLOCK OUTPUT at J500 on the AWG Board.
 - H The interconnect cable from J130 on the A30 GPIB board to J100 on the AWG board at the cable junction. See also Figure 6-21, page 6-44.
6. Remove the twelve screws on top of the AWG board and two from the rear panel.
7. Lift the AWG board up away from the main chassis to complete the removal.
8. To install do this procedure in reverse order then refer to the following procedures, in the order listed, to complete the assembly.
 - H *A70 Output Board*
 - H *Cabinet* (page 6-19).

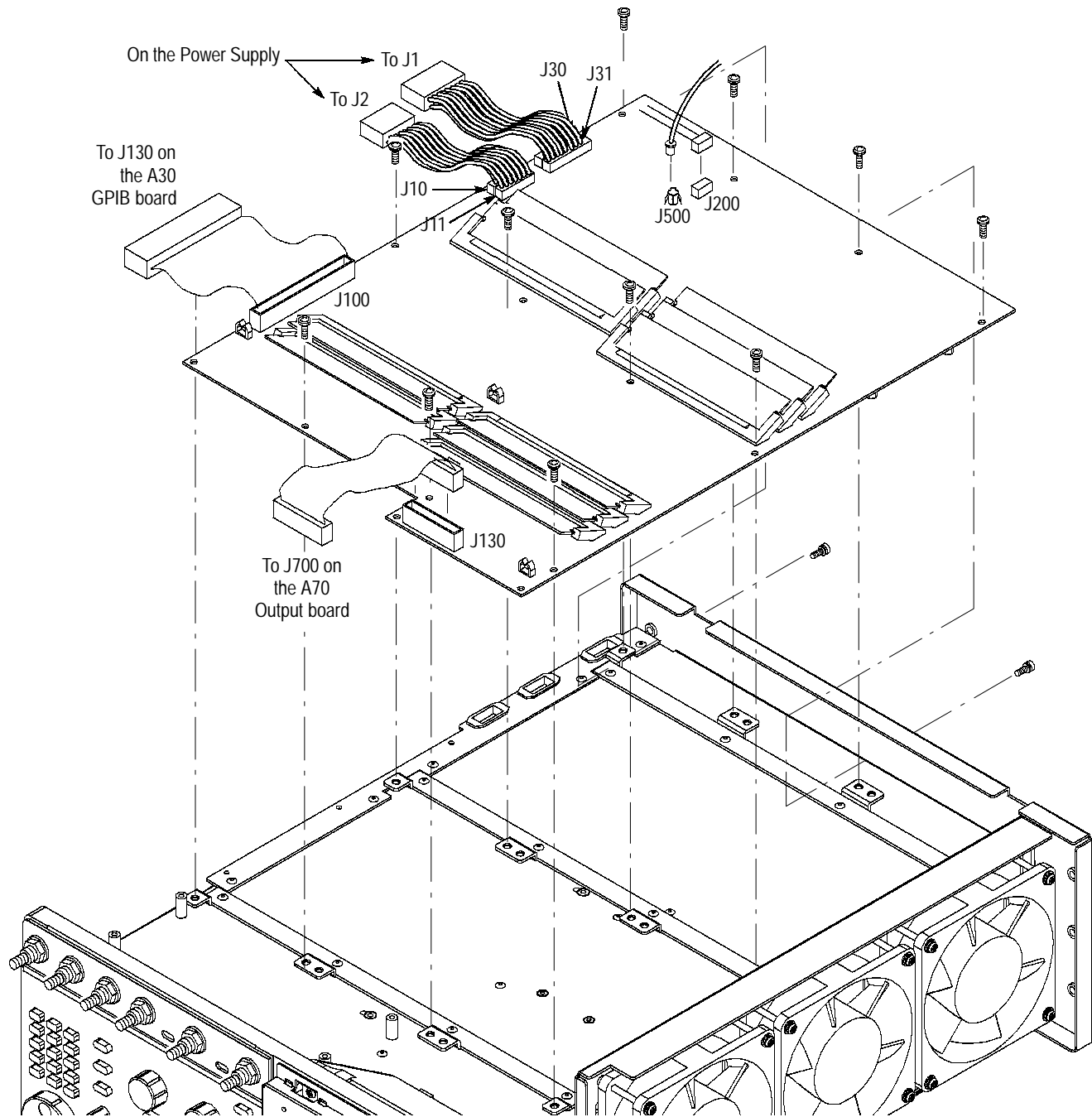

Figure 6-19: A50 AWG board removal

Rear Chassis You need a screwdriver with a size #2 Phillips tip (Items 1 and 3).

1. Locate the modules to be removed in Figure 6-3, page 6-13.

2. Do the procedure *PS100 Low Voltage Power Supply* (page 6-31) to remove the power supply module.
3. Do the procedure *A40 Clock Board* (page 6-37) to remove the interconnect cables.
4. Do the procedure *A50 AWG Board* (page 6-38) to remove the AWG board and the Output board.
5. Install the front cover (optional accessory) if it's not already installed.
6. Orient the waveform generator so its bottom is down on the work surface and its rear is facing you.
7. Remove the rear chassis using Figure 6-20 as a guide when doing the following substeps:
 - a. Unplug these cables:
 - H The GPIB interconnect cable at J110 on the A30 GPIB Board.
 - H The LAN interconnect cable at the connector on the LAN interface.
 - H The cable to DISPLAY MONITOR OUT at J127 and KEYBOARD at J128 on the A11 Connector board.
 - b. Remove the 5 screws securing the rear chassis to the main chassis.

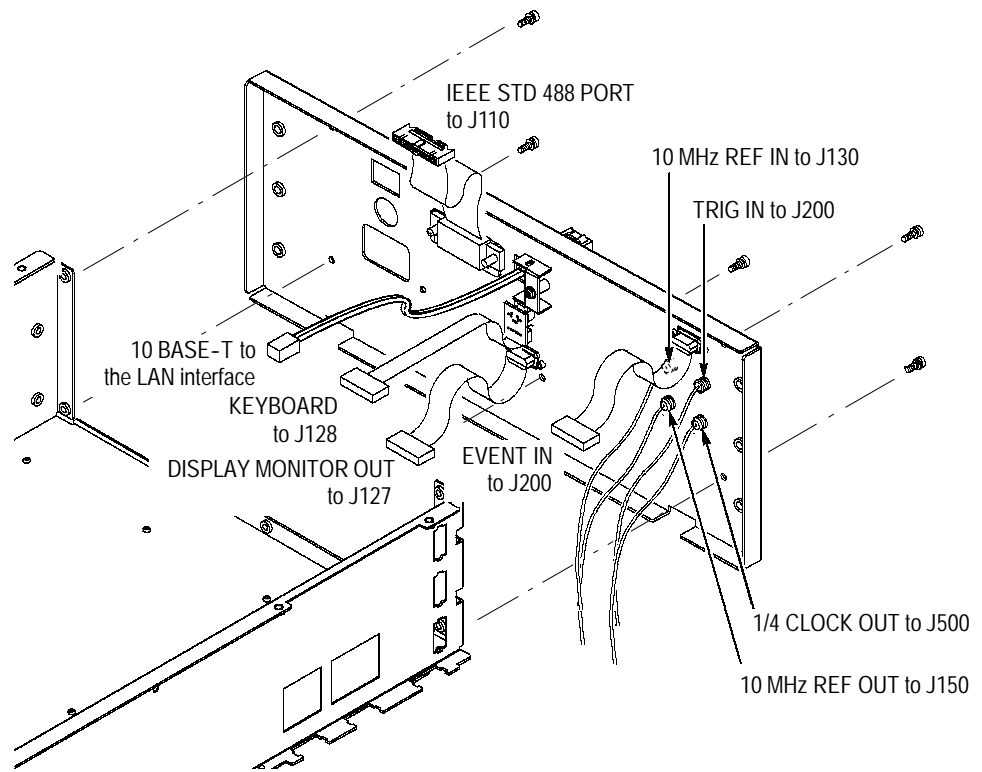

Figure 6-20: Rear Chassis removal

8. To install do this procedure in reverse order then see the following procedures, in the order listed to complete the assembly.
 - H *A50 AWG Board* (page 6-38)
 - H *A40 Clock Board* (page 6-37)
 - H *PS100 Low Voltage Power Supply* (page 6-31)
 - H *Cabinet* (page 6-19)

Procedures for Inner-Chassis Modules

You should have completed the *Access Procedure* on page 6-15 before doing any of the procedures for the Inner-Chassis modules. The procedures are presented in the following order:

- H *CPU unit*
 - H *CPU Board*
 - H *Hard disk and Flash disk*
 - H *LAN Board*
 - H *A30 GPIB Board*
 - H *Back Plane Board*
- H *Display Assembly and Supply Fuse*
- H *Front Subpanel*

CPU unit This procedure describes how to remove these circuit boards contained in the CPU unit:

- H CPU Board
- H Hard disk and Flash disk
- H LAN Board
- H A30 GPIB Board
- H Back Plane

NOTE. The Lithium polycarbon monofluoride battery on the CPU board is not user-replaceable. Removing the battery erases calendar backup data. Replace the CPU board as a unit.

You will need a screwdriver with a size #2 Phillips tip (Items 1 and 3).

1. Locate the modules to be removed in Figure 6-4, page 6-14.
2. Do the procedure *A11 Connector Board* (page 6-37) to remove the interconnect cables to the CPU board and the A30 GPIB board. It is not necessary to pull the Connector board out.
3. Orient the waveform generator so its bottom is down on the work surface and the right side facing you.

4. Remove the *CPU unit* using Figure 6-21 as a guide while doing the following substeps.
 - a. Unplug the GPIB interconnect cable at J110 on the A30 GPIB board and the LAN interconnect cable of the LAN interface board.
 - b. Unplug the interconnect cable from J100 on A50 AWG board.
 - c. Remove the two screws on the bottom and another two from the right side.
 - d. Lift the CPU Unit up away from the main chassis.

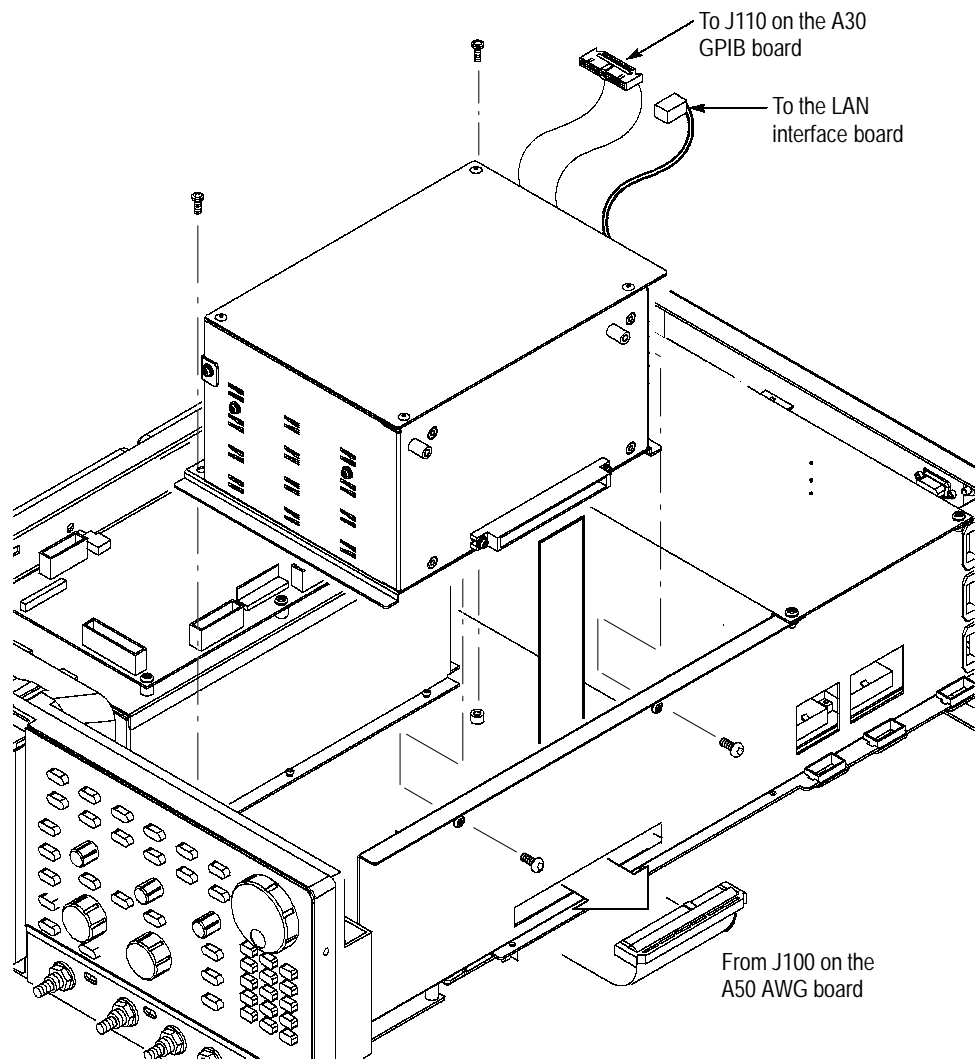

Figure 6-21: CPU unit removal

5. Remove the *CPU Board* using Figure 6-22 as a guide while doing the following substeps:
 - a. Unplug the VGA and COM1 connectors on the left side of the CPU board.
 - b. Unplug the interconnect cable from the flash disk.
 - c. Using a screwdriver with a size #2 Phillips tip, remove the screw securing the CPU board to the frame with a retainer on the the right side of the unit.
 - d. Remove the screw on the left side of the CPU board.
 - e. Grasp the board and slide it out of the unit.

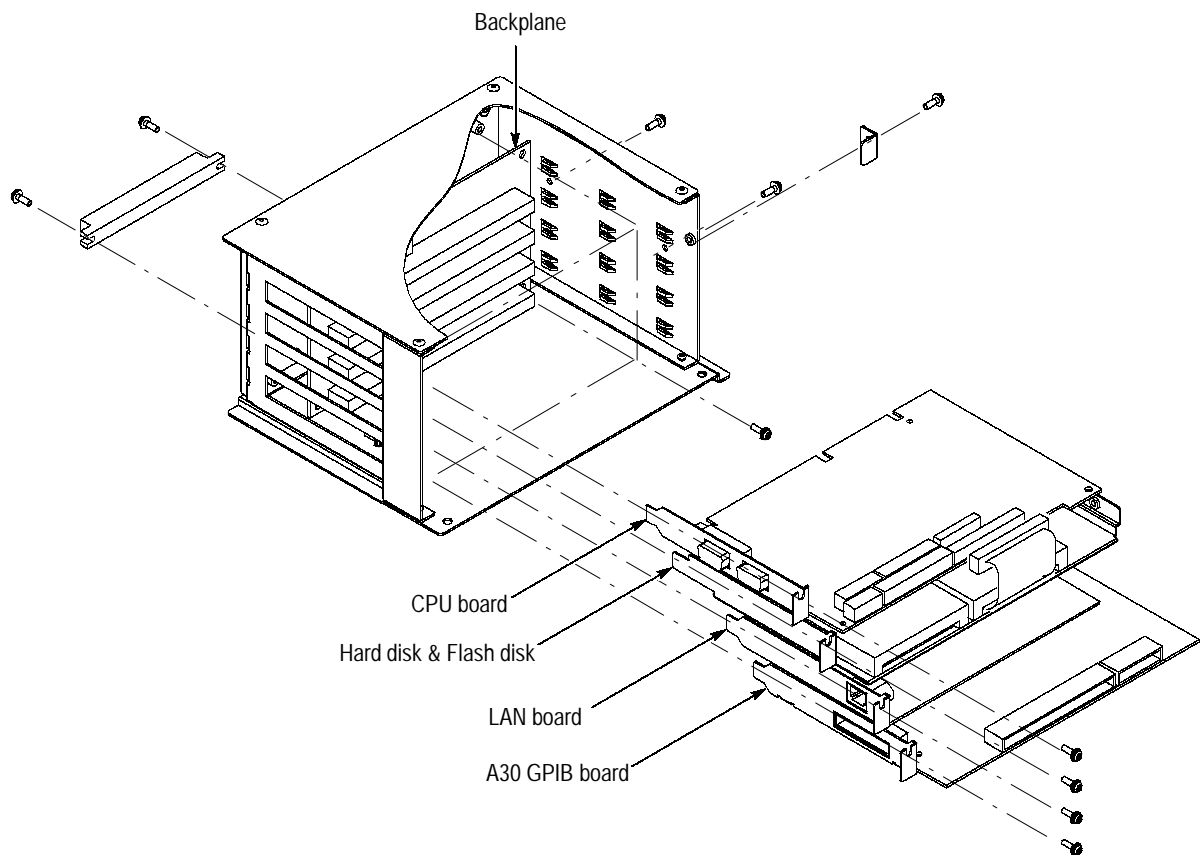

Figure 6-22: CPU, HDD/Flash disk, LAN, and GPIB boards removal

6. Remove the *Hard disk and Flash disk* using a screwdriver with a size #2 Phillips tip to remove the two screws securing the hard disk and flash disk bracket to the frame on the the right side of the CPU Unit. See Figure 6-22.
7. Remove the screw on the left side of the bracket.
8. Grasp the bracket and slide it out.
9. Using a screwdriver with a size Phillips #2 tip, remove the three screws securing the hard disk to the bracket. See Figure 6-23.
10. Remove the four screws securing the flash disk to the bracket.

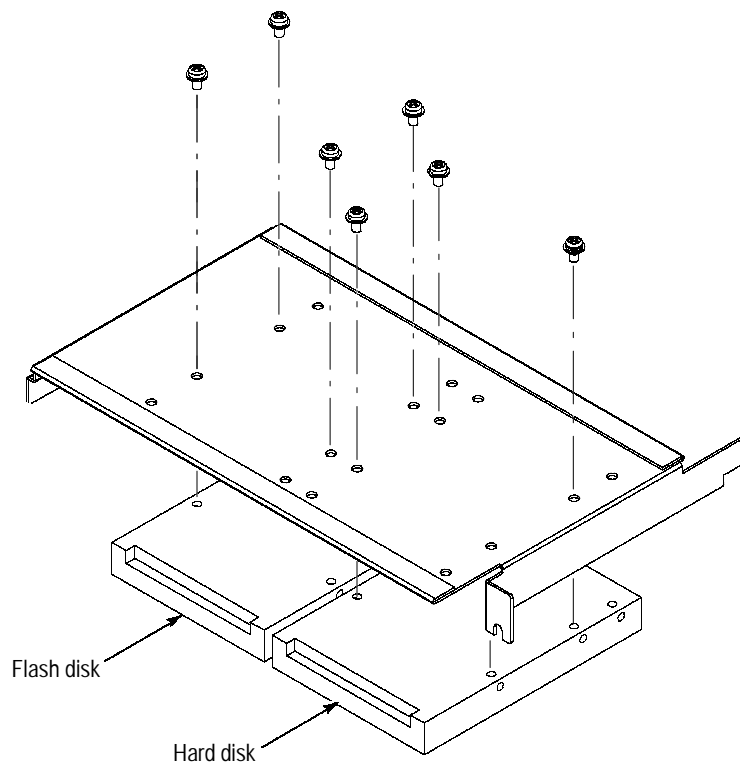

Figure 6-23: Hard disk and flash disk removal

11. Remove the *LAN Board* using a screwdriver with a size #2 Phillips tip to remove the screw on the left side of the LAN board. See Figure 6-22, page 6-44.
12. Grasp the board and slide it out.
13. Remove the *A30 GPIB Board* using a screwdriver with a size #2 Phillips tip, to remove the screw on the left side of the GPIB board. See Figure 6-22, page 6-44.
14. Grasp the board and slide it out.
15. Remove the *Back Plane*: by using a screwdriver with a size #2 Phillips tip to remove the four screws securing the board to the frame. See Figure 6-22, page 6-44.
16. Grasp the board and slide it out.
17. To install, do this procedure in reverse order.
18. Refer to the following procedures, in the order shown, to complete assembly of the waveform generator.
 - H *A11 Connector Board* (cables only, page 6-33)
 - H *Cabinet* (page 6-19)

Display Assembly and Supply Fuse

You will need a screwdriver with a size #2 Phillips tip (Items 1 and 3).

NOTE. The display and the display-driver board are a single module and must be removed and replaced as such. They are listed as a single module in the Replaceable Mechanical Parts list.

1. Locate the modules to be removed in Figure 6-4, on page 6-14.
2. Orient the waveform generator so its bottom is down on the work surface and its rear is facing you.
3. If you are servicing this fuse, remove the fuse from its fuse holder. Reverse the procedure to install.



WARNING. Use care when handling a display tube. If you break a display tube it may implode, scattering glass fragments with high velocity and possibly injuring you. Wear protective clothing, including safety glasses (preferably a full-face shield). Avoiding striking the display tube with or against any object.

Store the display tube face down in a protected location, placing it on a soft, nonabrasive surface to prevent scratching the face plate.

4. Take the precautions outlined in the warning above. See Figure 6-24 while doing the following substeps.
5. Unplug the display tube connector from the back of the display tube and the display tube yoke connector from the display circuit board (J340). Loosen the screw on the video board that holds the CRT sockets. Then pull back on the video board slightly. This separates the board from the socket.
6. Remove the two screws that secure the band circling the front of display tube to the front subpanel. Carefully guide display tube forward to partially remove it from the front subpanel and to access the anode lead connected to the display tube.



WARNING. High-voltage is present on the anode lead. Before unplugging the anode in the following substep, you must discharge it. Grounding a flat-blade screwdriver (Item 4) with an insulated handle to the chassis through a suitable grounding strap. Next, probe under the insulating cap of the anode lead and touch the lead's metal conductor to discharge. Repeat. After unplugging the anode in step 7, touch its metal conductor to the chassis for a few minutes to further ensure discharge.

7. Discharge the anode lead as described in the immediately preceding WARNING, unplug it from the display tube, and discharge that lead again.
8. Be sure you have read the WARNING on display tube handling and storage found at the start of this display tube removal procedure. Pull the display tube out through the front subpanel. Store as directed in the previous WARNING message.

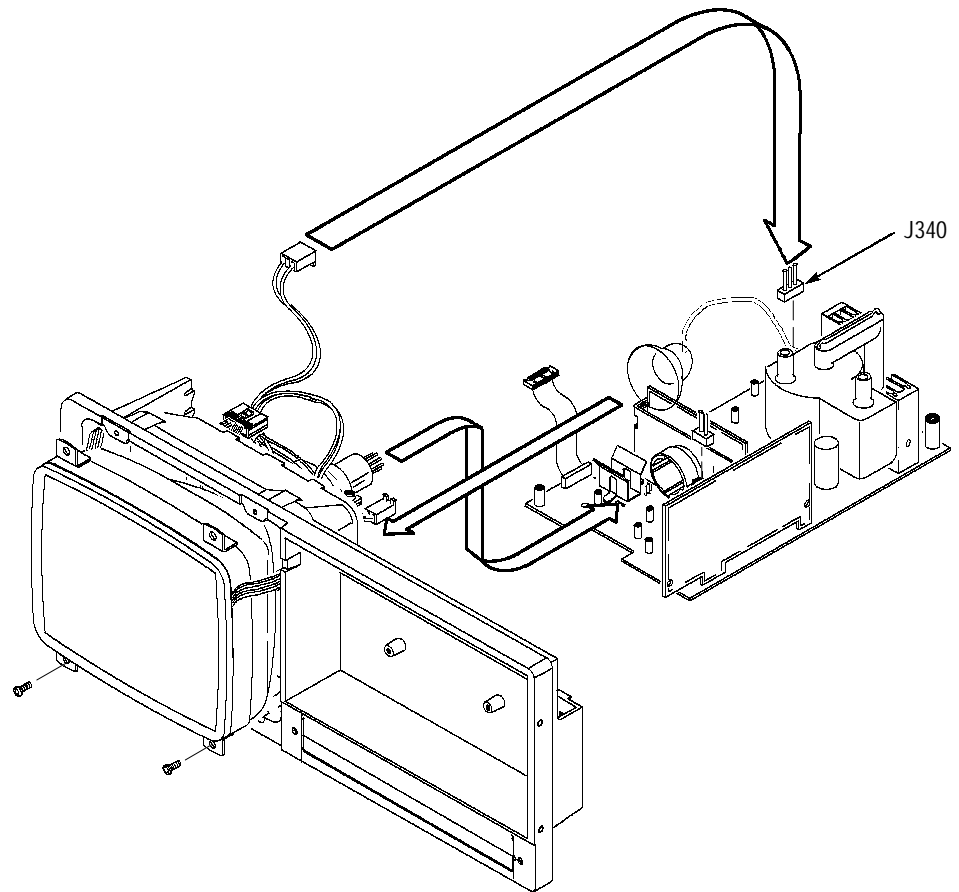

Figure 6-24: Display assembly removal

9. Remove the display supply board using Figure 6-25 as a guide.



CAUTION. *If any RTV Silicon is removed from the generator, it must be replaced in order to maintain the warranted characteristics for random vibration.*

10. Remove the six screws that mount the display-driver board to the main chassis.
11. Grasp the display driver board. Work from the front and top to tilt the board so its right edge is up and its left side is down and lift it out of the top of the generator's main chassis.

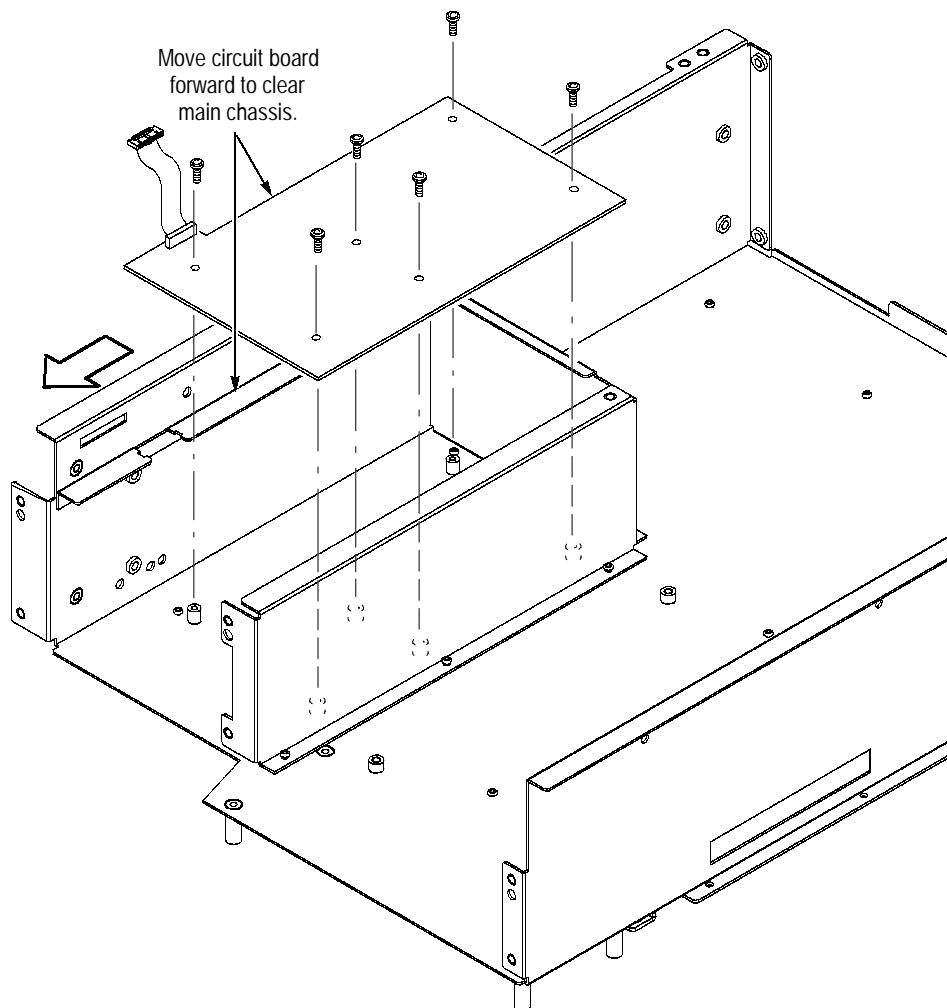

Figure 6-25: Display Driver Board removal

12. To install, do this procedure in reverse order.
13. See the following procedures, in the order shown, to complete reassembly of the waveform generator:
 - H *A11 Connector Board* (page 6-33)
 - H *Display-Frame Assembly*
 - H *Trim Ring, Menu Buttons, and Output Panel* (page 6-22)
 - H *Cabinet* (page 6-19) (completes reassembly)

Front Subpanel

You will need a screwdriver with a size #2 Phillips tip (Items 1 and 3).

1. Do the procedure *Display Assembly and Supply Fuse* (page 6-47). Do not remove the display-driver board.
2. Locate the modules to be removed in Figure 6-3, page 6-13.
3. Orient the waveform generator so its rear is down on the work surface and its bottom is facing you.
4. Remove the front subpanel by removing the six screws securing the front subpanel to the main chassis. (See Figure 6-26 for screw locations.) Lift the front subpanel up away from the main chassis to complete the removal.
5. Do the following substeps to install the front subpanel and assemble the generator:
 - a. Align the front subpanel to the main chassis, taking care to ensure that the main chassis slips into its alignment slot on the front subpanel (see magnified view, Figure 6-26.) Then install the six screws removed in step 4.
 - b. See the procedure *Display Assembly and Supply Fuse* (page 6-47) to install the display-frame assembly and display tube.

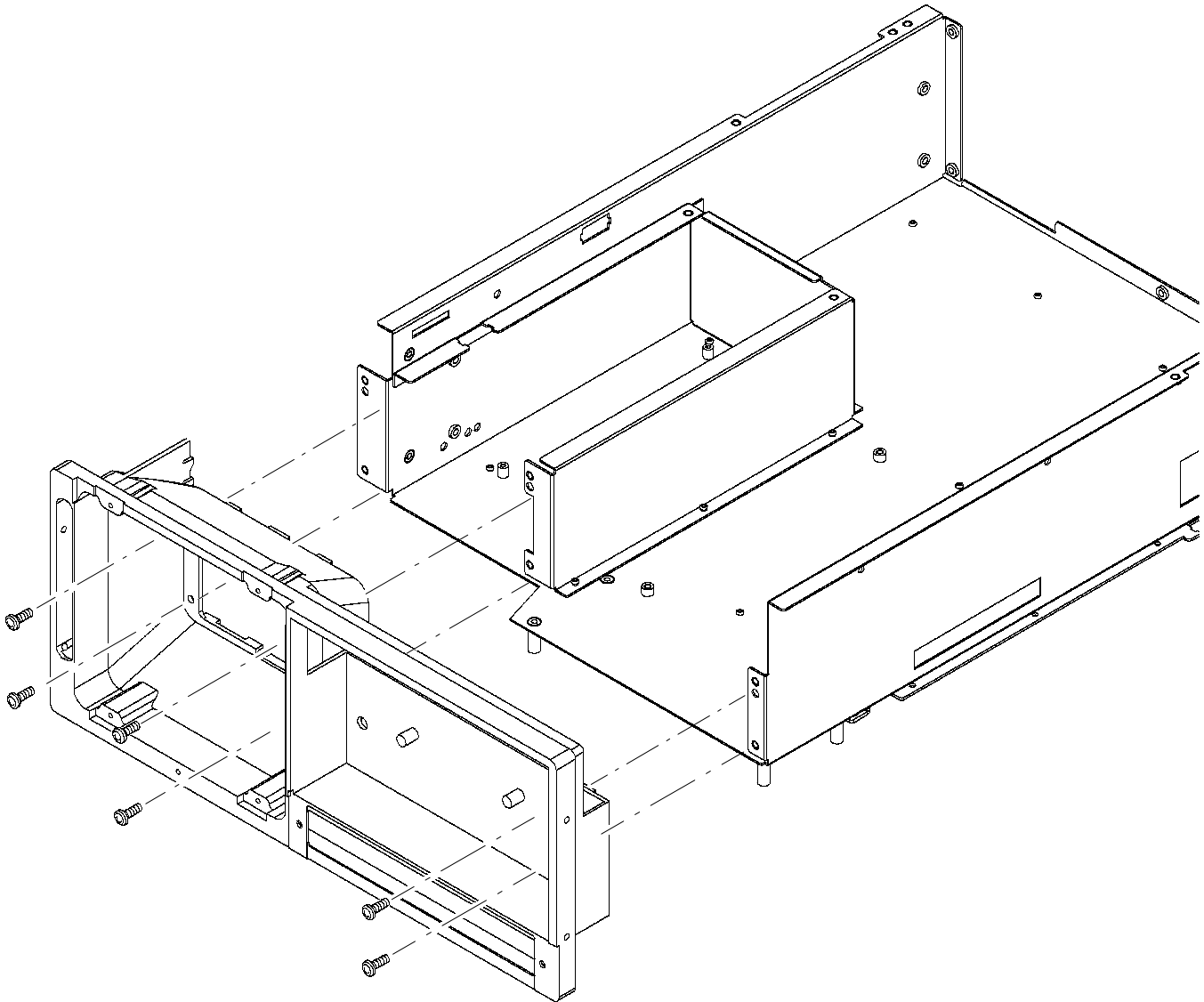

Figure 6-26: Front subpanel removal

- c. See the following procedures, in the order listed, for instructions for installing the remaining modules.
 - H *A11 Connector Board* (page 6-33)
 - H *Display-Frame Assembly*
 - H *Trim Ring, Menu Buttons, and Output Panel* (page 6-22)
 - H *Cabinet* (page 6-19)

Troubleshooting

This subsection contains information and procedures designed to help you isolate faulty modules in the waveform generator. If a module needs to be replaced, follow the *Removal and Installation Procedures* located in this section.

This subsection consists of the following flowcharts:

- H Figure 6-27: Primary Troubleshooting Procedure
- H Figure 6-28: Troubleshooting Procedure 1 — Power Supply Module
- H Figure 6-30: Troubleshooting Procedure 2 — CPU or Front-panel Module
- H Figure 6-32: Troubleshooting Procedure 3 — Monitor Module
- H Figure 6-37: Troubleshooting Procedure 4 — Module Isolation

Diagnostics

The waveform generator has two levels of internal diagnostics that focus on verifying, adjusting, and if need be, isolating faulty modules.

Both levels of internal diagnostics report any bad modules and/or interfaces. If a bad module and/or interface is found, use the troubleshooting procedures in this section to determine which module needs to be replaced.

The two levels of diagnostics are the short confidence set and the extended set that tests the oscilloscope circuitry in depth and takes more time. At power on, the waveform generator automatically executes the short set. The extended set is optional and is executed by using the following procedure:

Prerequisites: Power on the waveform generator and allow a 20 minute warm-up before doing this procedure.

1. *Display the diagnostics menu:* Press **UTILITY ! Diag.**
2. *Select the menu:* Select **ALL** using the general purpose knob.
3. *Run the diagnostics:* Press **Execute Diagnostic.**
4. *Wait:* The internal diagnostics do an exhaustive verification of proper oscilloscope function. This verification will take several minutes. When finished, the waveform generator will display a report of any bad modules and/or interfaces.



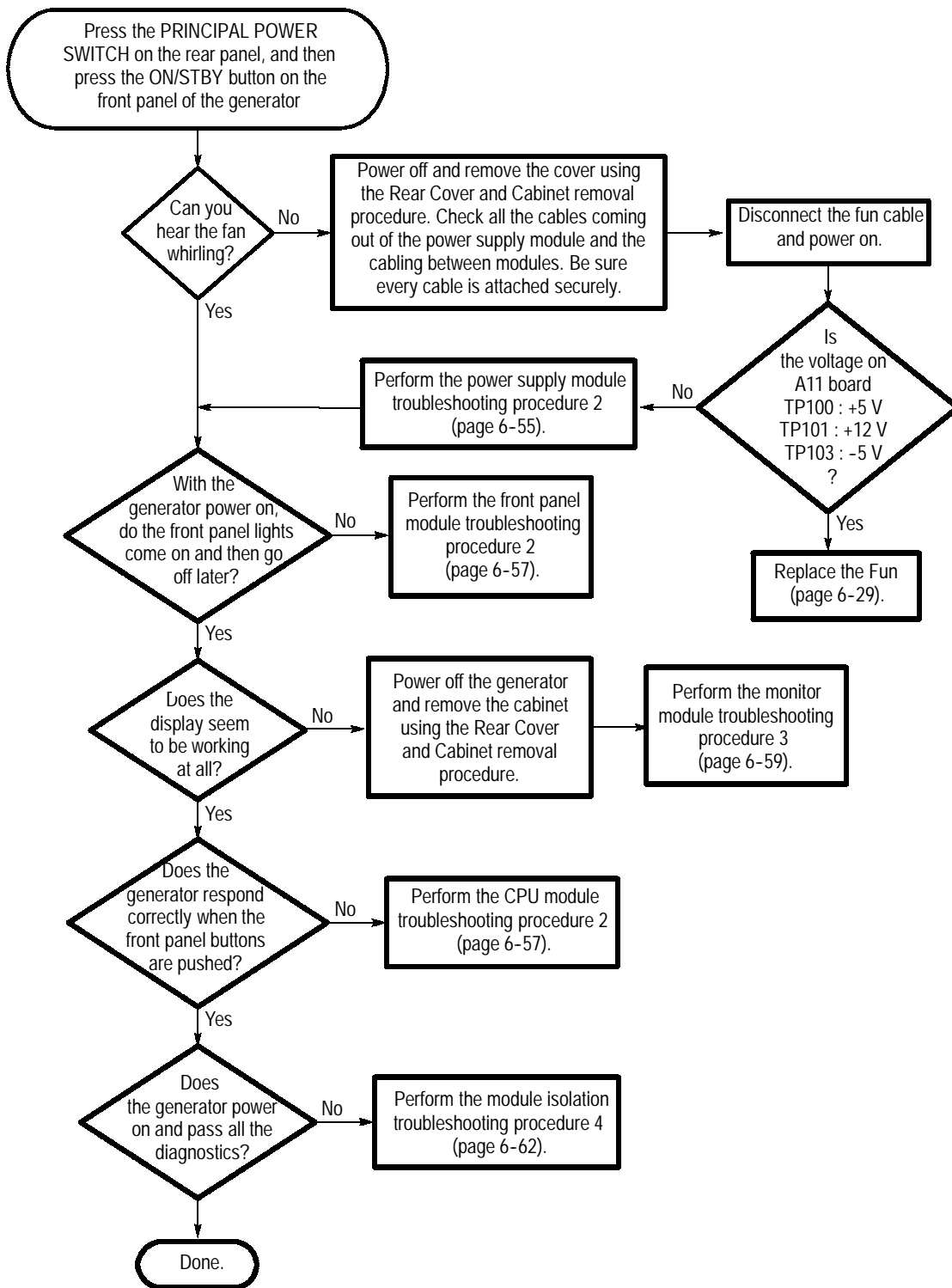

Figure 6-27: Primary troubleshooting procedure

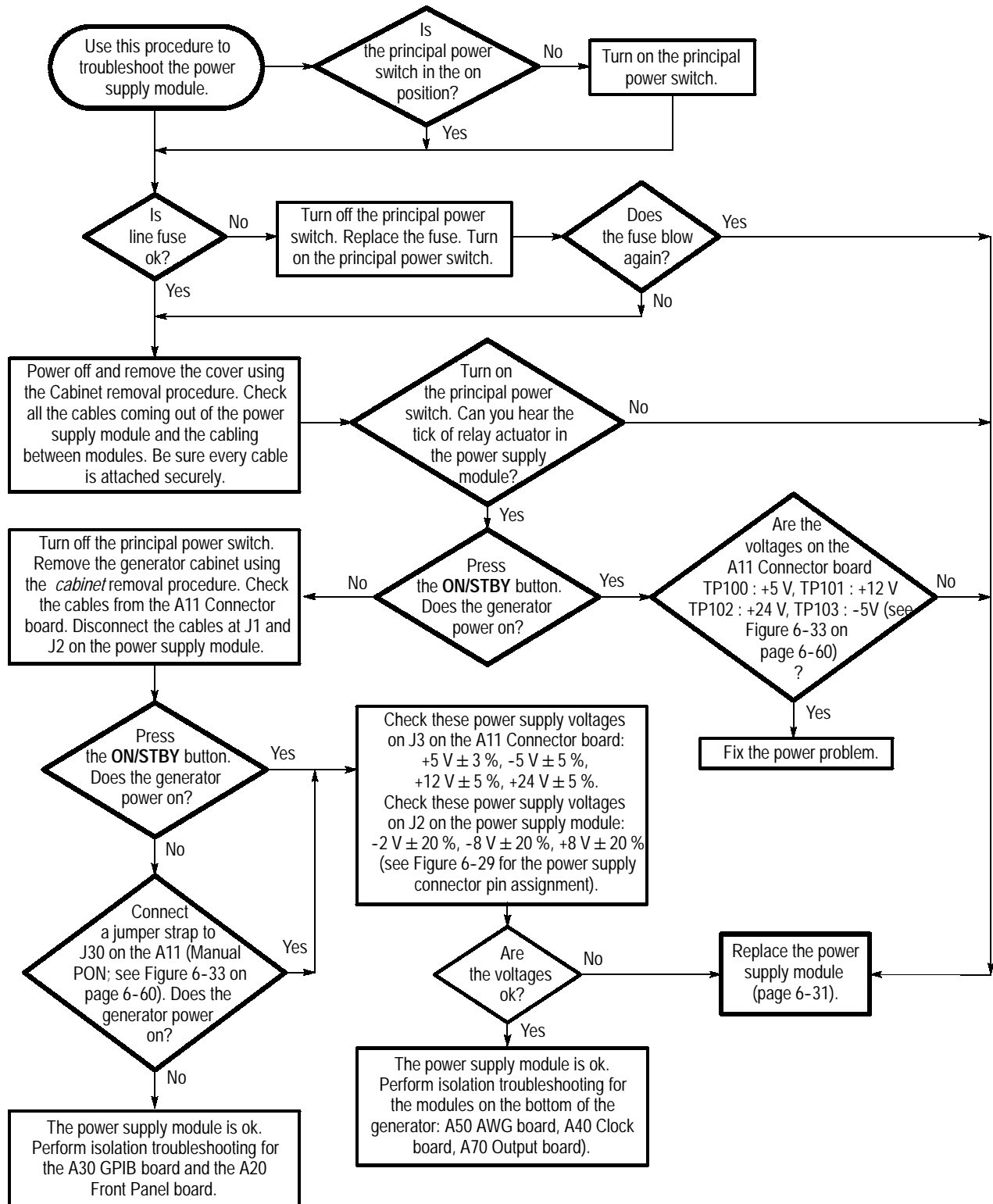

Figure 6-28: Troubleshooting procedure 1 — Power Supply module

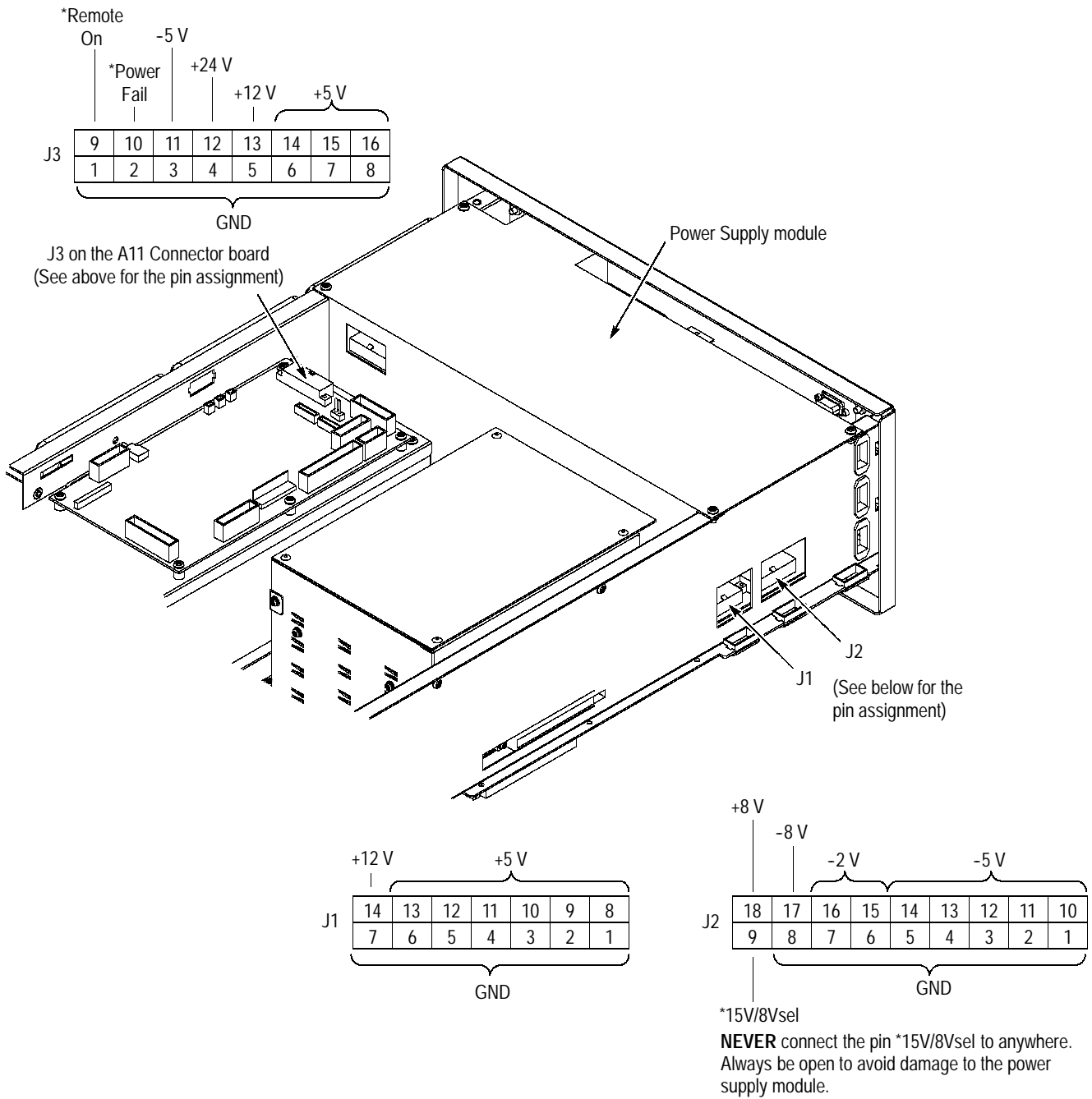

Figure 6-29: Power Supply connectors

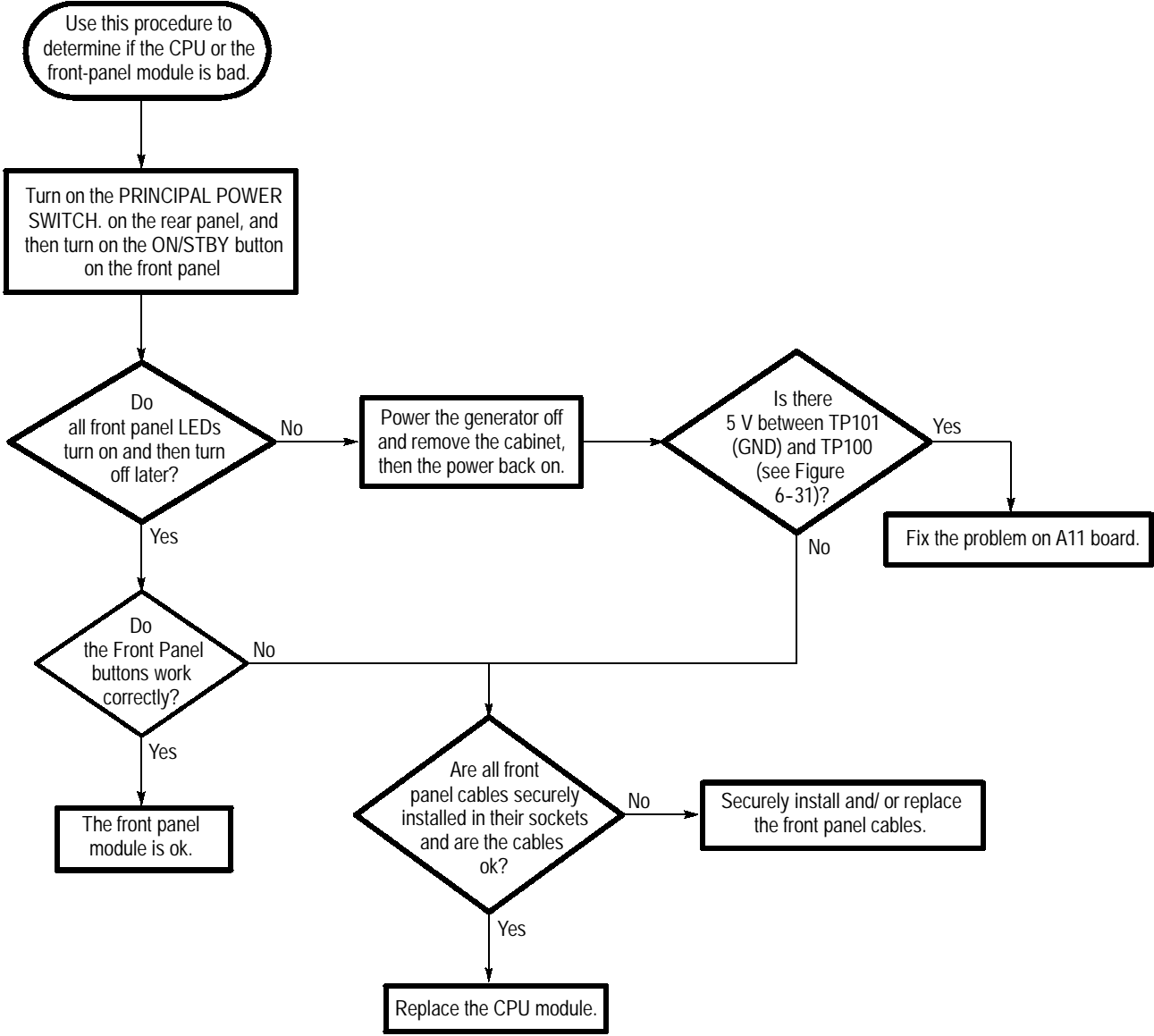

Figure 6-30: Troubleshooting procedure 2 — CPU or Front Panel module

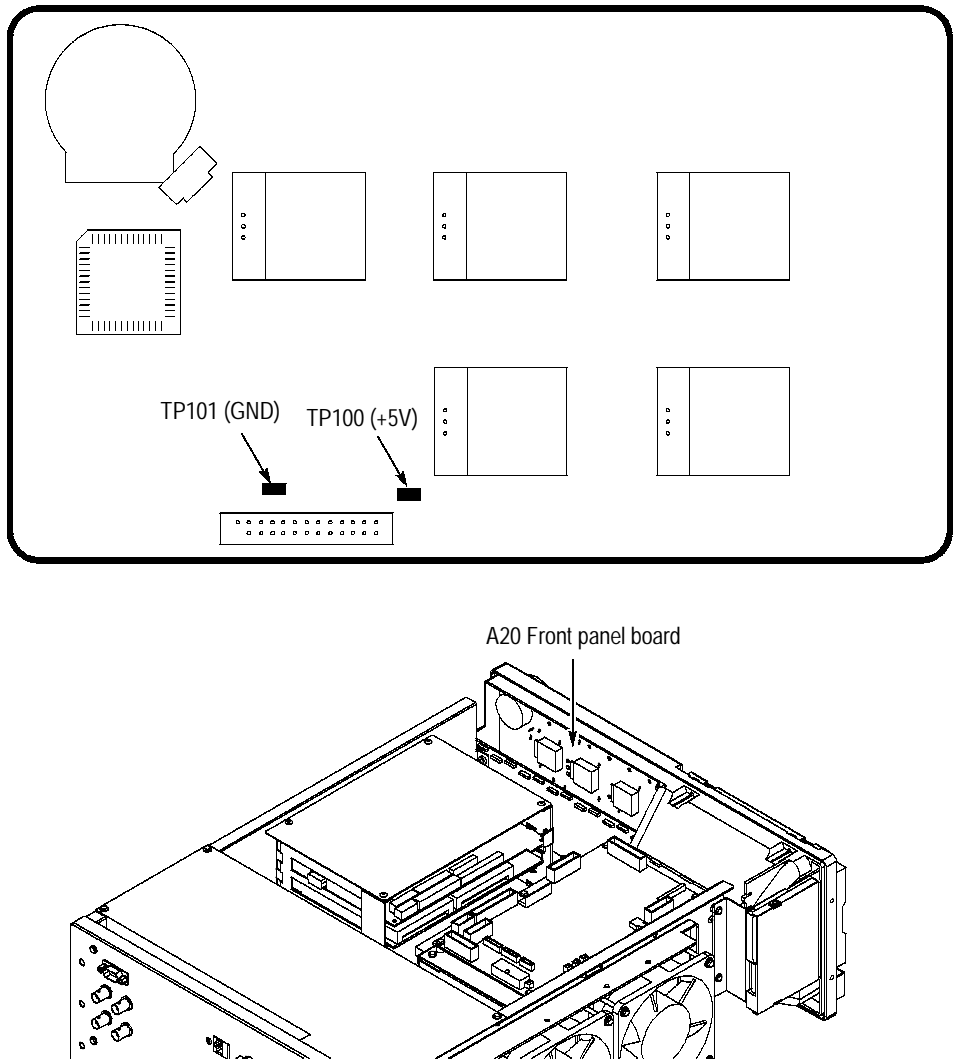

Figure 6-31: A20 Front Panel board

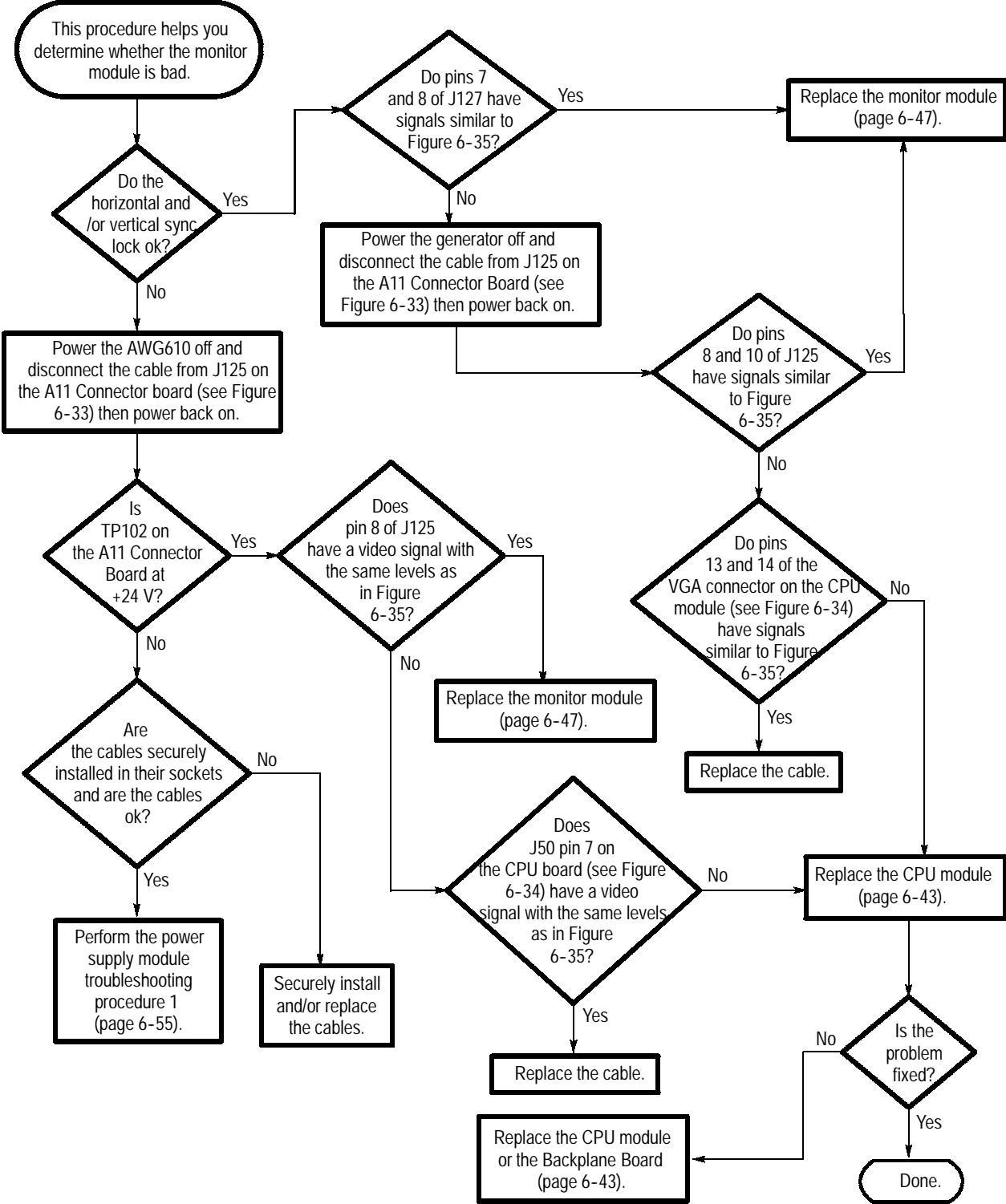

Figure 6-32: Troubleshooting procedure 3 — Monitor module

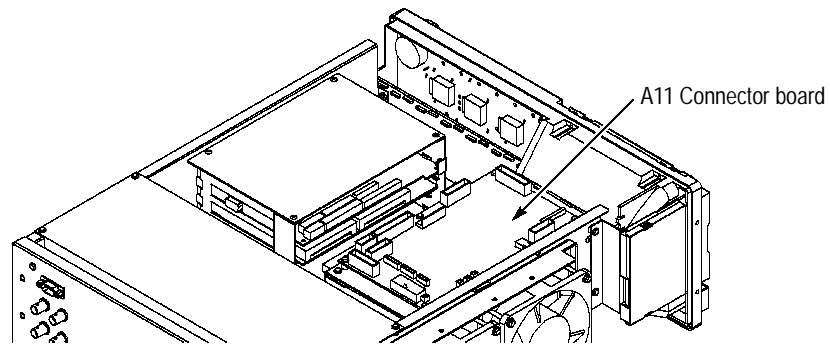
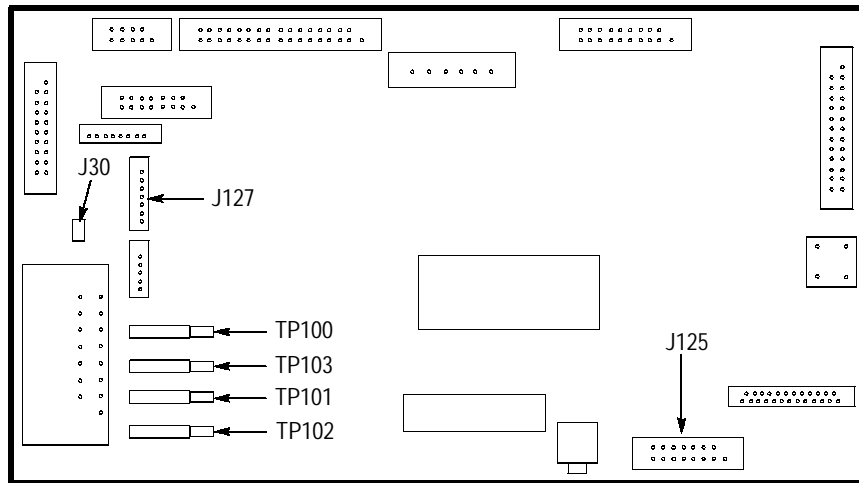

Figure 6-33: A11 Connector board

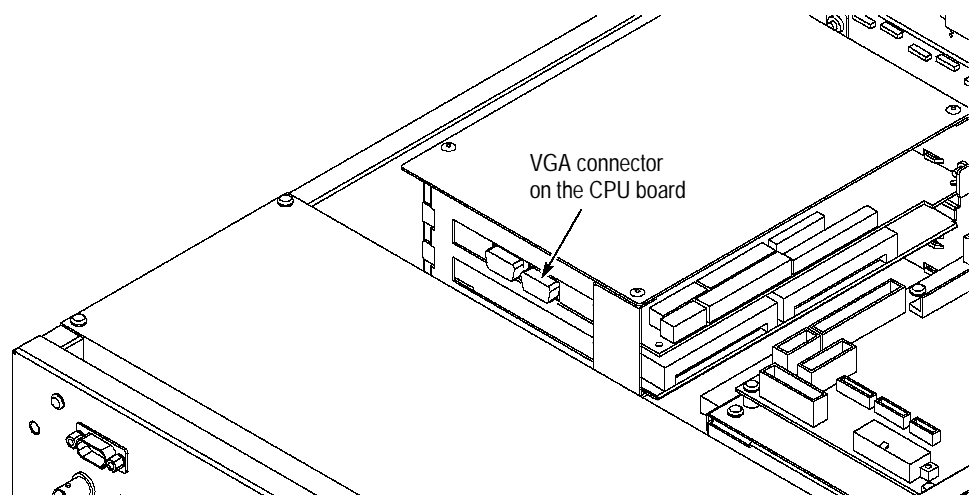

Figure 6-34: Location of the VGA connector

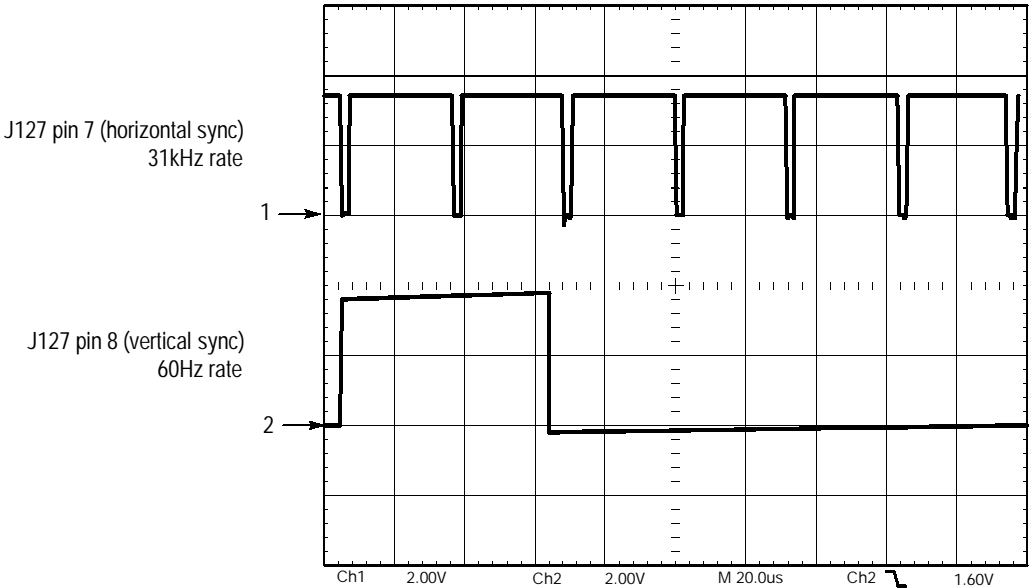

Figure 6-35: Horizontal and vertical sync signals

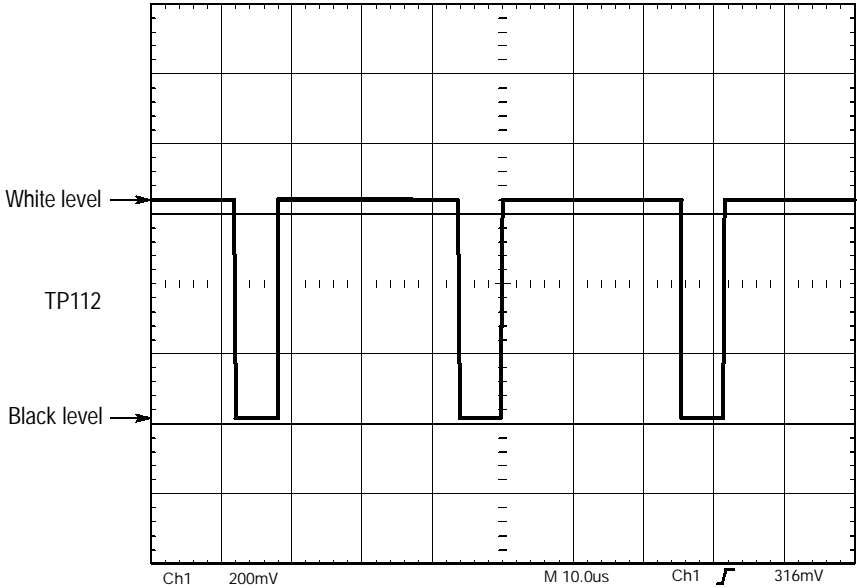

Figure 6-36: A video signal with white and black levels

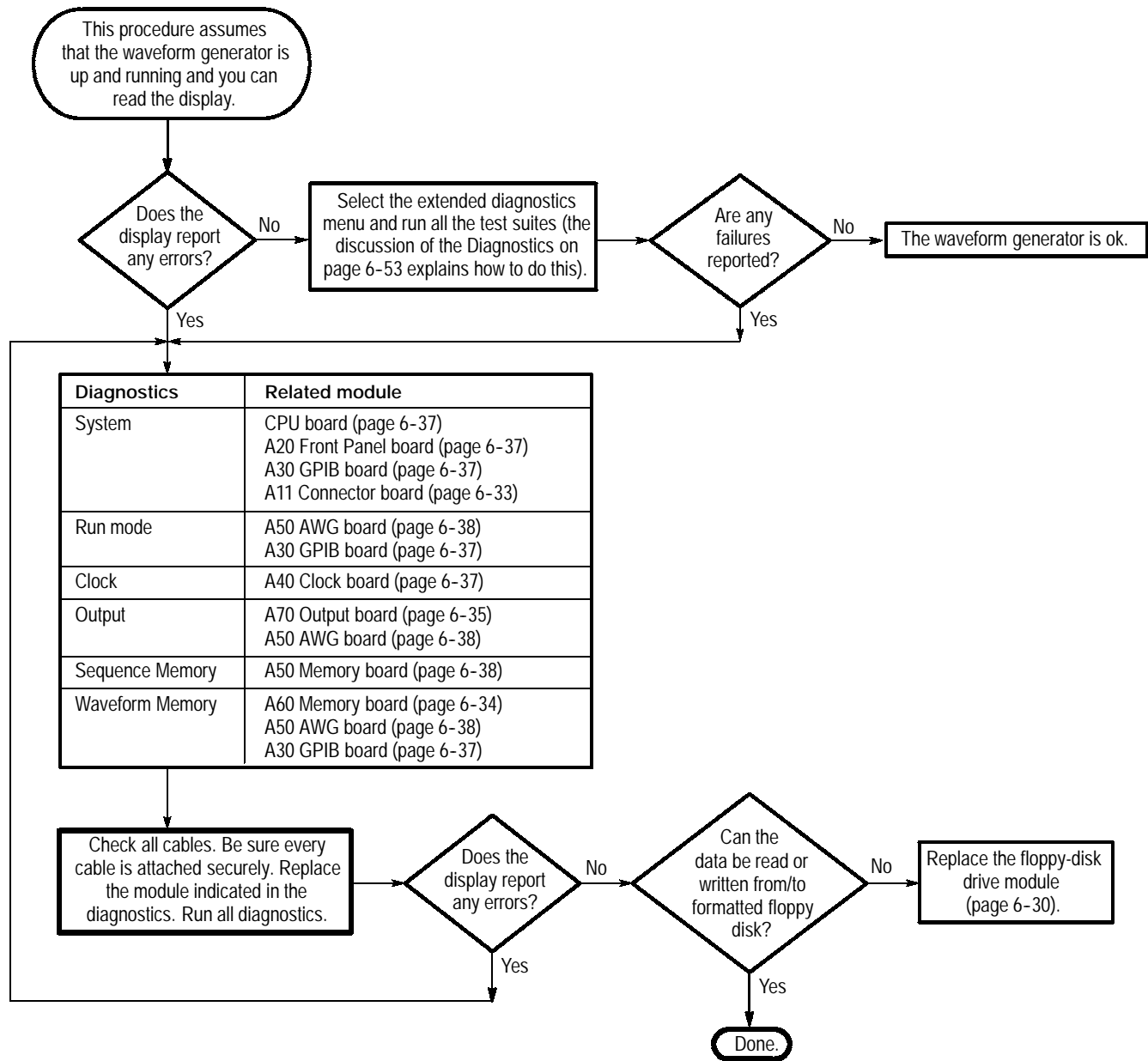

Figure 6-37: Troubleshooting procedure 4 — Module isolation

Messages and Codes

Table 6-5 lists instrument error codes and their meaning.

Table 6-5: Device errors

Error code	Error message
1101	CH1 internal offset calibration failure
1102	CH1 output offset calibration failure
1103	CH1 gain calibration failure
1104	CH1 gain difference calibration failure
1105	CH1 direct output gain calibration failure
1111	CH1 x3dB attenuator calibration failure
1112	CH1 x6dB attenuator calibration failure
1113	CH1 x12dB attenuator calibration failure
1114	CH1 x20dB attenuator calibration failure
1115	CH1 x5dB 1 attenuator calibration failure
1116	CH1 x5dB 2 attenuator calibration failure
1117	CH1 x10dB 2 attenuator calibration failure
1121	CH1 10MHz filter calibration failure
1122	CH1 20MHz filter calibration failure
1123	CH1 50MHz filter calibration failure
1124	CH1 100MHz filter calibration failure
1125	CH1 200MHz filter calibration failure
1201	CH2 or $\overline{\text{CH1}}$ internal offset calibration failure
1202	CH2 or $\overline{\text{CH1}}$ output offset calibration failure
1203	CH2 or $\overline{\text{CH1}}$ gain calibration failure
1204	CH2 or $\overline{\text{CH1}}$ gain difference calibration failure
1205	CH2 or $\overline{\text{CH1}}$ direct output gain calibration failure
1211	CH2 or $\overline{\text{CH1}}$ x3dB attenuator calibration failure
1212	CH2 or $\overline{\text{CH1}}$ x6dB attenuator calibration failure
1213	CH2 or $\overline{\text{CH1}}$ x12dB attenuator calibration failure
1214	CH2 or $\overline{\text{CH1}}$ x20dB attenuator calibration failure
1215	CH2 or $\overline{\text{CH1}}$ x5dB 1 Attenuator calibration failure
1216	CH2 or $\overline{\text{CH1}}$ x5dB 2 Attenuator calibration failure

Table 6-5: Device errors (cont.)

Error code	Error message
1217	CH2 or $\overline{\text{CH1}}$ x10dB 2 Attenuator calibration failure
1221	CH2 or $\overline{\text{CH1}}$ 10MHz filter calibration failure
1222	CH2 or $\overline{\text{CH1}}$ 20MHz filter calibration failure
1223	CH2 or $\overline{\text{CH1}}$ 50MHz filter calibration failure
1224	CH2 or $\overline{\text{CH1}}$ 100MHz filter calibration failure
1225	CH2 or $\overline{\text{CH1}}$ 200MHz filter calibration failure
2100	System failure
2101	Real-time clock power
2102	Configuration record and checksum status
2103	Incorrect configuration
2104	Memory size miscompare
2105	Fixed-disk drive initialization status
2106	Time status
2110	Front panel failure
2111	Front panel configuration
2112	Front panel communication
2113	Front panel RAM
2114	Front panel ROM
2115	Front panel A/D
2116	Front panel timer
2301	A30 board failure
2401	Clock delay data not found
2402	Clock delay data checksum
2700	Calibration data failure
2701	Calibration data not found
2702	Calibration data checksum
2703	Calibration data invalid
3100	Control register failure
3101 to 3104	Control register bit0 to bit3
3200	Event table data bus failure
3201 to 3216	Event table data bus bit0 to bit15
3250	Event table address bus failure
3251 to 3254	Event table address bus bit0 to bit3

Table 6-5: Device errors (cont.)

Error code	Error message
3300	Event table memory chip select failure
3301	Event table memory chip select 0
3302	Event table memory chip select 1
3350	Event table memory chip cell failure
3351	Event table memory chip 0
3352	Event table memory chip 1
4100	A40 board failure
4101	PLL 500MHz locked
4102	PLL 600MHz unlocked
4103	PLL 1350MHz unlocked
4104	PLL 1500MHz locked
4105	Low band VCO PLL error
4106	High band VCO PLL error
5100	Sequence memory data bus failure
5101 to 5116	Sequence memory data bus bit0 to bit15
5117 to 5132	Sequence memory high data bus bit0 to bit15
5133 to 5148	Sequence memory opcode data bus bit0 to bit15
5150	Sequence memory address bus failure
5151 to 5174	Sequence memory address bus bit0 to bit23
5200	Sequence memory chip select failure
5201 to 5206	Sequence memory chip select 0 to select 5
5250	Sequence memory chip cell failure
5251 to 5256	Sequence memory chip 0 to chip 5
5300	CH1 Waveform memory data bus failure
5301 to 5316	CH1 Waveform memory data bus bit0 to bit15
5330	CH1 Waveform memory module data bus failure
5331 to 5340	CH1 Waveform memory module data bus module0 to module9
5350	CH1 Waveform memory address bus failure
5351 to 5374	CH1 Waveform memory address bus bit0 to bit23
5400	CH1 Waveform memory chip select failure
5401 to 5449	CH1 Waveform memory chip select 0 to select 48
5500	CH1 Waveform memory chip cell failure
5501 to 5580	CH1 Waveform memory chip 0 to chip 79

Table 6-5: Device errors (cont.)

Error code	Error message
5600	CH2 or $\overline{\text{CH1}}$ Waveform memory data bus failure
5601 to 5616	CH2 or $\overline{\text{CH1}}$ Waveform memory data bus bit0 to bit15
5650	CH2 or $\overline{\text{CH1}}$ Waveform memory address bus failure
5651 to 5674	CH2 or $\overline{\text{CH1}}$ Waveform memory address bus bit0 to bit23
5700	CH2 or $\overline{\text{CH1}}$ Waveform memory chip select failure
5701 to 5748	CH2 or $\overline{\text{CH1}}$ Waveform memory chip select 0 to select 47
5800	CH2 or $\overline{\text{CH1}}$ Waveform memory chip cell failure
5801 to 5848	CH2 or $\overline{\text{CH1}}$ Waveform memory chip 0 to chip 47
5900	CH1 Arb D/A failure
5901 to 5912	CH1 Arb D/A data bit0 to bit11
5950	CH2 Arb D/A failure
5951 to 5962	CH2 Arb D/A data bit0 to bit11
7110	CH1 output offset failure
7111	CH1 output offset
7120	CH1 internal offset failure
7121	CH1 internal offset
7130	CH1 Arb gain failure
7131	CH1 Arb gain
7140	CH1 attenuator failure
7141	CH1 3dB attenuator
7142	CH1 6dB attenuator
7143	CH1 12dB attenuator
7144	CH1 20dB attenuator
7145	CH1 5dB attenuator 1
7146	CH1 5dB attenuator 2
7147	CH1 10dB attenuator
7150	CH1 filter failure
7151	CH1 10MHz filter
7152	CH1 20MHz filter
7153	CH1 50MHz filter
7154	CH1 100MHz filter
7155	CH1 200MHz filter
7170	CH1 output key failure

Table 6-5: Device errors (cont.)

Error code	Error message
7171	CH1 output key
7210	CH2 or $\overline{\text{CH1}}$ output offset failure
7211	CH2 or $\overline{\text{CH1}}$ output offset
7220	CH2 or $\overline{\text{CH1}}$ internal offset failure
7221	CH2 or $\overline{\text{CH1}}$ internal offset
7230	CH2 or $\overline{\text{CH1}}$ Arb gain failure
7231	CH2 or $\overline{\text{CH1}}$ Arb gain
7240	CH2 or $\overline{\text{CH1}}$ attenuator failure
7241	CH2 or $\overline{\text{CH1}}$ 3dB attenuator
7242	CH2 or $\overline{\text{CH1}}$ 6dB attenuator
7243	CH2 or $\overline{\text{CH1}}$ 12dB attenuator
7244	CH2 or $\overline{\text{CH1}}$ 20dB attenuator
7245	CH2 or $\overline{\text{CH1}}$ 5dB 1 attenuator
7246	CH2 or $\overline{\text{CH1}}$ 5dB 2 attenuator
7247	CH2 or $\overline{\text{CH1}}$ 10dB attenuator
7250	CH2 or $\overline{\text{CH1}}$ filter failure
7251	CH2 or $\overline{\text{CH1}}$ 10MHz filter
7252	CH2 or $\overline{\text{CH1}}$ 20MHz filter
7253	CH2 or $\overline{\text{CH1}}$ 50MHz filter
7254	CH2 or $\overline{\text{CH1}}$ 100MHz filter
7255	CH2 or $\overline{\text{CH1}}$ 200MHz filter
7270	CH2 or $\overline{\text{CH1}}$ output key failure
7271	CH2 or $\overline{\text{CH1}}$ output key



Options and Accessories

Options and Accessories

This appendix describes the various options as well as the standard and optional accessories that are available for the AWG610 Arbitrary Waveform Generator.

Options

Table 7-1 lists the power cord options.

Table 7-1: Power cord options

	Option #	Label	Description
	A1	Universal European power cord	220 V, 50 Hz power cord Fuse 5A (T) (IEC 127) Fuse Cap Cable Retainer
	A2	UK power cord	240 V, 50 Hz power cord Fuse 5A (T) (IEC 127) Fuse Cap Cable Retainer
	A3	Australian power cord	240 V, 50 Hz power cord Fuse 5A (T) (IEC 127) Fuse Cap Cable Retainer
	A4	North American power cord	240 V, 60 Hz power cord Cable Retainer
	A5	Switzerland power cord	220 V, 50 Hz power cord Fuse 5A (T) (IEC 127) Fuse Cap Cable Retainer

Table 7-1: Power cord options (Cont.)

	Option #	Label	Description
	D1	Test Result Report	A calibration data test result report will be provided with the AWG610 Arbitrary Waveform Generator when this option is specified.
	1R	Rackmount	Waveform generator comes configured for installation in a 19 inch wide instrument rack. For later field conversions, order kit # 016-1675-XX.
	1S	WaveWriter S3FTx00	<p>WaveWriter is an application program used to create waveforms for advanced signal generating and processing instruments. Many Tektronix instruments, such as arbitrary waveform generators and oscilloscopes with the "save-on-delta" feature, are enhanced by this program. WaveWriter helps users configure waveforms with a minimum of effort.</p> <p>With the WaveWriter package, you can create new waveforms or edit waveforms acquired from various instrument sources. WaveWriter gives you interactive control of the waveform generating process. WaveWriter operates within the Microsoft Windows™ environment.</p> <p>A Certificate of Traceable Calibration is provided when this option is specified.</p>
	10	78 M byte Flash Disk	<p>A 78 Mbyte flash disk addition. The hard disk is deleted when this option is ordered.</p> <p>The AWG610 Arbitrary Waveform Generator retains the state of the front panel ON/STB switch. The ON/STB switch must be left in the on position to be able to power on and power off the instrument using the principal power switch.</p>

Standard Accessories

The waveform generator comes standard with the accessories listed in Table 7-2.

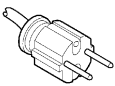
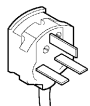
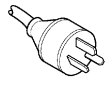
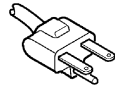
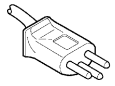
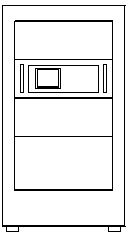
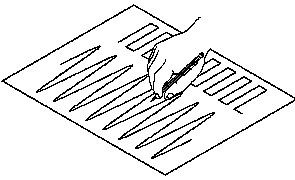
Table 7-2: Standard accessories

Accessory	Part number
User Manual	071-0554-XX
Programmer Manual	071-0555-XX
Sample waveform floppy disk, 3.5 inch	063-3216-XX
Sample program floppy disk, 3.5 inch	063-3217-XX
Performance check/adjustment floppy disk, 3.5 inch	063-3218-XX
Fuse, 10 A FAST (UL198G, 3 AG)	159-0407-00
Fuse cap	200-2264-00
SMA Terminator, 50 Ω , Male, 2 ea	015-1022-00
U.S. Power Cord	161-0230-01

Optional Accessories

You can also order the optional accessories listed in Table 7-3.

Table 7-3: Optional accessories

Accessory	Part number
Service Manual	071-0556-XX
Front cover	200-3696-01
Rack Mount Kit (for field conversion)	016-1675-XX
GPIB cable	012-0991-00
BNC cable, 50 Ω , 0.6 m (2 ft)	012-1342-00
BNC cable, 50 Ω , 2.5 m (8.2 ft), double-shield	012-1256-00
SMA cable, 50 Ω , 0.5 m, (1.64 ft), Male-Male	174-1427-00
SMA cable, 50 Ω , 1.0 m, (3.28 ft), Male-Male	174-1341-00
SMA cable, 50 Ω , 1.2 m, (3.94 ft), Male-Male	174-1428-00
SMA cable, 50 Ω , 1.5 m (4.92 ft), Male-Male	012-1565-00
SMA delay cable, 1 ns, Male-Male	015-0562-00
SMA delay cable, 2 ns, Male-Male	015-0560-00
SMA delay cable, 5 ns, Male-Male	015-0561-00

Table 7-3: Optional accessories (cont.)

Accessory	Part number
SMA T-connector, Male-Female & Female	015-1016-00
SMA 50 Ω terminator, Male	015-1022-00
SMA 50 Ω divider, Male	015-1014-00
SMA delay cable, 1 ns, Male-Male	015-0562-00
SMA-BNC adapter, Male-Female	015-0554-00
SMA-BNC adapter, Female-Male	015-0572-00
SMA adapter kit	020-1693-00
BNC terminator, 50 Ω	011-0049-01
BNC power divider, 50 Ω , DC to 300 MHz, VSWR: 1.2 max.	015-0660-00
BNC low pass filter, 400 MHz	015-0659-00
BNC low pass filter, 200 MHz	015-0658-00
BNC low pass filter, 100 MHz	015-0657-00
Transformer	CT1
Transformer	CT2
Transformer	CT6
Cart	K475
WaveWriter: AWG and waveform creation editor	S3FTx00



Replaceable Electrical Parts



Electrical Parts List

The modules that make up this instrument are a combination of mechanical and electrical subparts. Therefore, all replaceable modules are listed in *Replaceable-Mechanical Parts*. Refer to that section for part numbers when using this manual.



Diagrams

Diagrams

This section contains following diagrams:

H Block Diagram for the AWG610

H Interconnect Diagram for the AWG610

Block diagrams show the modules and functional blocks in the waveform generator. Interconnect diagrams show how the modules in the waveform generator connect together.

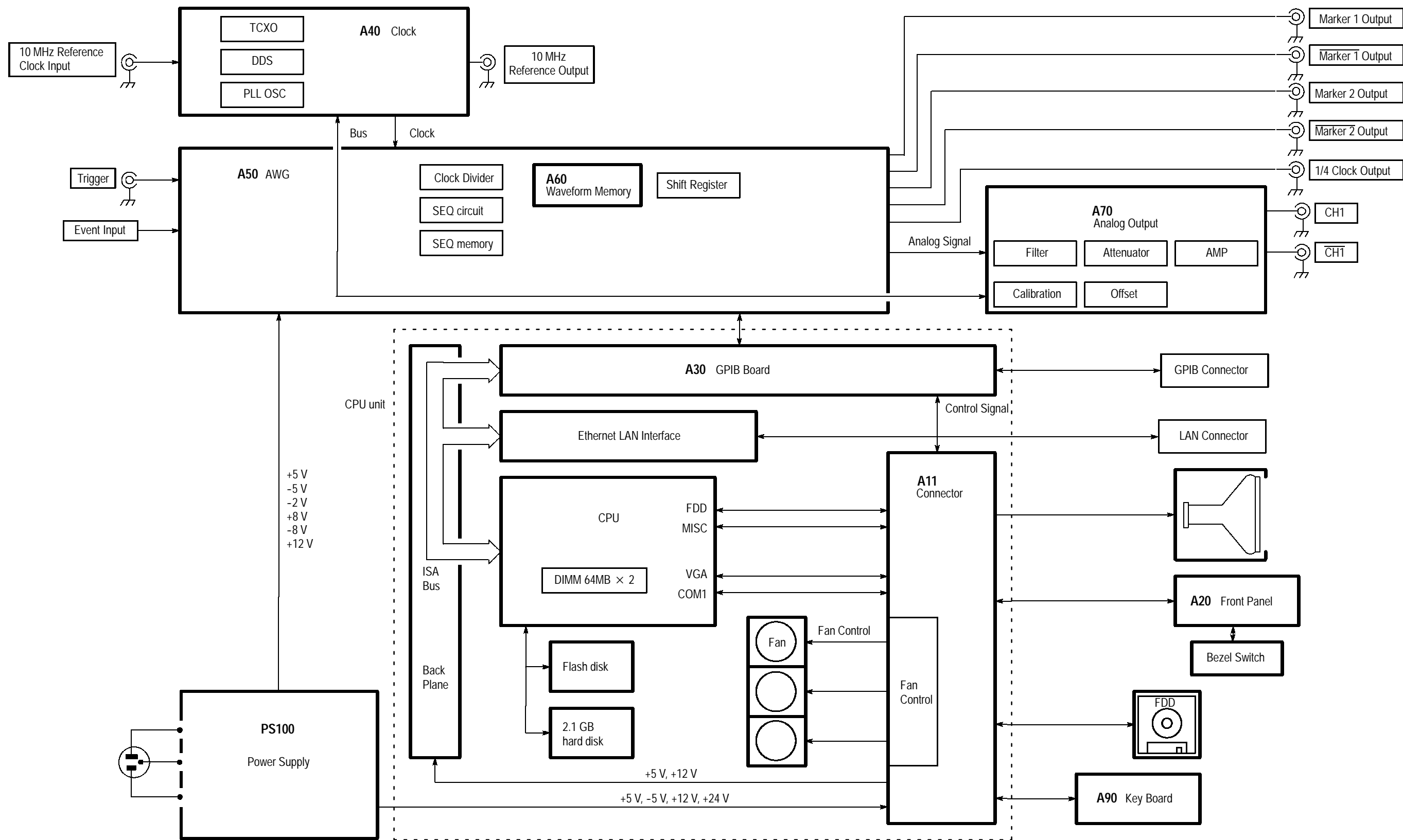

Figure 9-1: Block diagram

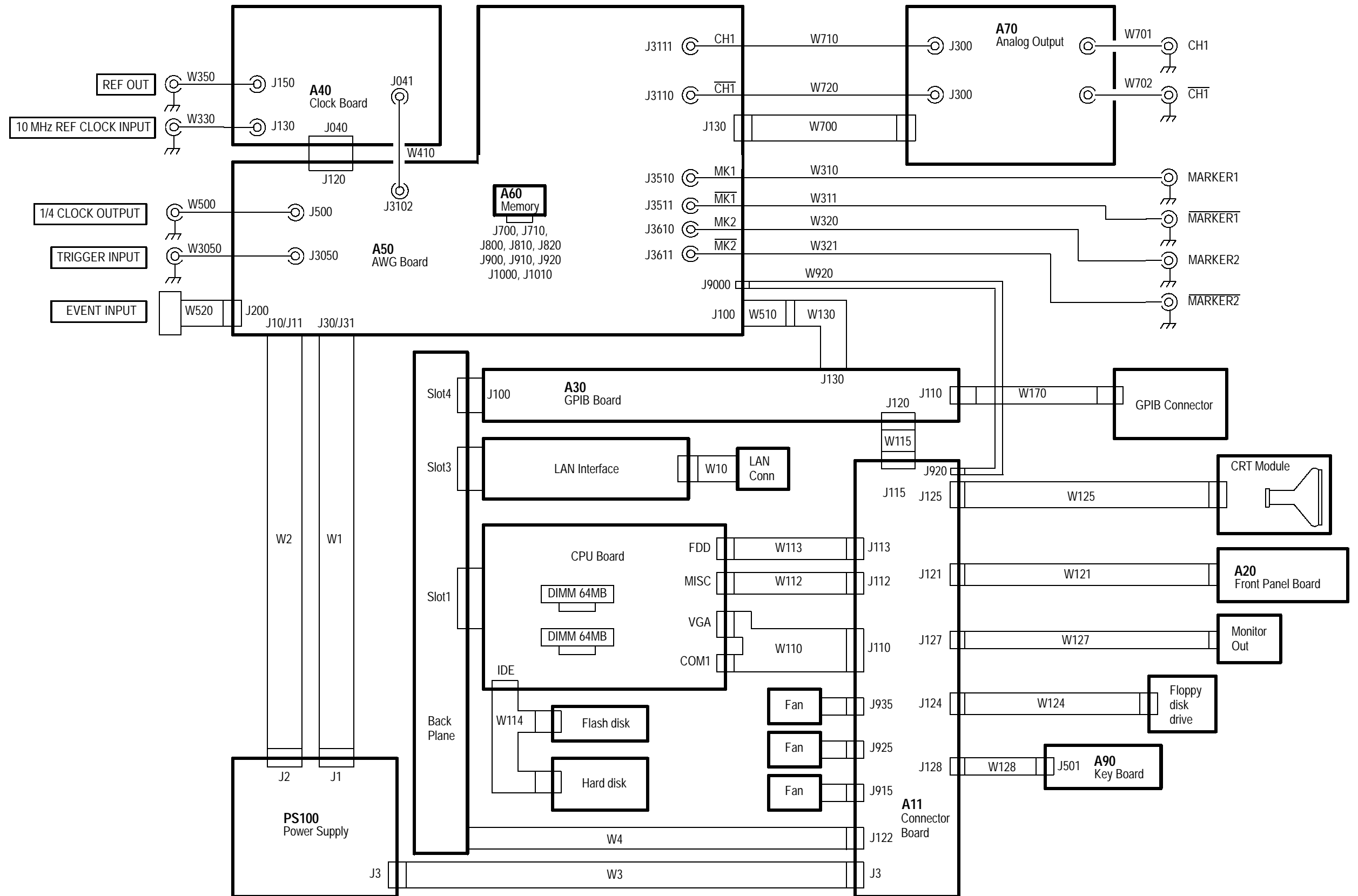

Figure 9-2: Interconnections



Replaceable Mechanical Parts

Replaceable Mechanical Parts

This section contains a list of the replaceable modules for the AWG610 Arbitrary Waveform Generator. Use this list to identify and order replacement parts.

Parts Ordering Information

Replacement parts are available through your local Tektronix field office or representative.

Changes to Tektronix instruments are sometimes made to accommodate improved components as they become available and to give you the benefit of the latest circuit improvements. Therefore, when ordering parts, it is important to include the following information in your order.

- H Part number
- H Instrument type or model number
- H Instrument serial number
- H Instrument modification number, if applicable

If you order a part that has been replaced with a different or improved part, your local Tektronix field office or representative will contact you concerning any change in part number.

Change information, if any, is located at the rear of this manual.

Part Number Revision Level

Tektronix part numbers contain two digits that show the revision level of the part. For most parts in this manual, you will find the letters XX in place of the revision level number.



When you order parts, Tektronix will provide you with the most current part for your product type, serial number, and modification (if applicable). At the time of your order, Tektronix will determine the part number revision level needed for your product, based on the information you provide.

Module Servicing Modules can be serviced by selecting one of the following three options. Contact your local Tektronix service center or representative for repair assistance.

Module Exchange. In some cases you may exchange your module for a remanufactured module. These modules cost significantly less than new modules and meet the same factory specifications. For more information about the module exchange program, call 1-800-TEK-WIDE, extension 6630.

Module Repair and Return. You may ship your module to us for repair, after which we will return it to you.

New Modules. You may purchase replacement modules in the same way as other replacement parts.

Using the Replaceable Parts List

This section contains a list of the mechanical and/or electrical components that are replaceable for the generator. Use this list to identify and order replacement parts. The following table describes each column in the parts list.

Parts List Column Descriptions

Column	Column Name	Description
1	Figure & Index Number	Items in this section are referenced by component number.
2	Tektronix Part Number	Use this part number when ordering replacement parts from Tektronix.
3 and 4	Serial Number	Column three indicates the serial number at which the part was first effective. Column four indicates the serial number at which the part was discontinued. No entries indicates the part is good for all serial numbers.
5	Qty	This indicates the quantity of parts used.
6	Name & Description	An item name is separated from the description by a colon (:). Because of space limitations, an item name may sometimes appear as incomplete. Use the U.S. Federal Catalog handbook H6-1 for further item name identification.
7	Mfr. Code	This indicates the code of the actual manufacturer of the part. (Code to name and address cross reference is located after this page.)
8	Mfr. Part Number	This indicates the actual manufacturer's or vendor's part number.

Abbreviations Abbreviations conform to American National Standard ANSI Y1.1-1972.

Mfr. Code to Manufacturer Cross Index The following table cross indexes codes, names, and addresses of manufacturers or vendors of components listed in the parts list.

Manufacturers Cross Index

Mfr. Code	Manufacturer	Address	City, State, Zip Code
S3109	FELLER	72 VERONICA AVE UNIT 4	SUMMERSET NJ 08873
TK0392	NORTHWEST FASTENER SALES INC	8058 SW NIMBUS AVENUE	BEAVERTON OR 97008
TK0435	LEWIS SCREW CO	4300 S RACINE AVE	CHICAGO IL 60609-3320
TK1163	POLYCAST INC	9898 SW TIGARD ST	TIGARD OR 97223
TK1287	ENOCH MFG CO	14242 SE 82ND DR PO BOX 98	CLACKAMAS OR 97015
TK1908	PLASTIC MOLDED PRODUCTS	4336 SO ADAMS	TACOMA WA 98409
TK1918	SHIN-ETSU POLYMER AMERICA INC	1181 NORTH 4TH ST	SAN JOSE CA 95112
TK2058	TDK CORPORATION OF AMERICA	1600 FEEHANVILLE DRIVE	MOUNT PROSPECT, IL 60056
TK2432	UNION ELECTRIC	15/F #1, FU-SHING N. ROAD	TAIPEI, TAIWAN ROC
TK2548	XEROX BUSINESS SERVICES DIV OF XEROX CORPORATION	14181 SW MILLIKAN WAY	BEAVERTON OR 97077
OJR05	TRIQUEST CORP	3000 LEWIS AND CLARK HWY	VANCOUVER WA 98661-2999
OKB01	STAUFFER SUPPLY	810 SE SHERMAN	PORTLAND OR 97214
00779	AMP INC	2800 FULLING MILL PO BOX 3608	HARRISBURG PA 17105
07416	NELSON NAME PLATE CO	3191 CASITAS	LOS ANGELES CA 90039-2410
2W733	BELDEN CORPORATION	2200 US HIGHWAY 27 SOUTH PO BOX 1980	RICHMOND IN 47375-0010
24931	SPECIALTY CONNECTOR CO INC	2100 EARLYWOOD DR PO BOX 547	FRANKLIN IN 46131
6D224	HARBOR TRI-TEC A BERG ELECTRONICS COMPANY	14500 SOUTH BROADWAY	GARDENA, CA 90248
61058	MATSUSHITA ELECTRIC CORP OF AMERICA PANASONIC INDUSTRIAL CO DIV	TWO PANASONIC WAY	SECAUCUS NJ 07094
61857	SAN-0 INDUSTRIAL CORP	91-3 COLIN DRIVE	HOLBROOK NY 11741
61935	SCHURTER INC	1016 CLEGG COURT	PETALUMA CA 94952-1152
64537	KDI/TRIANGLE ELECTRONICS	60 S JEFFERSON ROAD	WHIPPANY, NJ 07981
73743	FISCHER SPECIAL MFG CO	111 INDUSTRIAL RD	COLD SPRING KY 41076-9749
75915	LITTELFUSE TRACOR INC SUB OF TRACOR INC	800 E NORTHWEST HWY	DES PLAINES IL 60016-3049
78189	ILLINOIS TOOL WORKS INC SHAKEPROOF DIV	ST CHARLES ROAD	ELGIN IL 60120
80009	TEKTRONIX INC	14150 SW KARL BRAUN DR PO BOX 500	BEAVERTON OR 97077-0001
86928	SEASTROM MFG CO INC	701 SONORA AVE	GLENDALE CA 91201-2431
98291	SEAELECTRO CORP BICC ELECTRONICS	40 LINDEMAN DR	TURNBULL CT 06611-4739

Replaceable Mechanical Parts

Replaceable Parts List

Fig. & Index Number	Tektronix Part Number	Serial No. Effective	Serial No. Discont'd	Qty	Name & Description	Mfr. Code	Mfr. Part Number
1-1	390-1201-00			1	CABINET,ASSY:AWG610,AL	80009	3901201XX
-2	348-1115-00			2	FOOT,CABINET:SLATE GRAY,PLASTIC	80009	3481115XX
-3	212-0210-00			6	SCREW,MACHINE:M5X20MM L,PNH,STL,MFZN-C, CROSS REC JIS B1111	80009	ORDER BY DESC
-4	159-0407-00			1	FUSE,CARTRIDGE:3AG,10A,250V ,FAST (AMERICAN)	80009	159040700
	159-0210-00				FUSE,CART:DIN 5 X 20MM,5AMP,250VSLOW (EUROPEAN)	61857	ET 5 AMP
-5	200-2264-00			1	CAP,FUSEHOLDER:3AG FUSES (AMERICAN)	61935	FEK 031.1666
	200-2265-00			1	CAP,FUSEHOLDER:5 X 20MM FUSES (EUROPEAN)	61935	FEK 031.1663
-6	161-0230-01			1	CABLE ASSY,PWR,:3,18 AWG,92 L,SVT,TAN (STANDARD ACCESSORY)	TK2432	ORDER BY DESC
-7	334-9967-00			1	MARKER,IDENT:MKD AWG610,POLYCARBONATE	80009	3349967XX
-8	101-0142-00			1	TRIM,DECORATIVE:FRONT	80009	1010142XX
-9	214-4287-00			1	ACTUATOR:ELASTOMER MAT,FRONT PANEL,RUBBER	80009	2144287XX

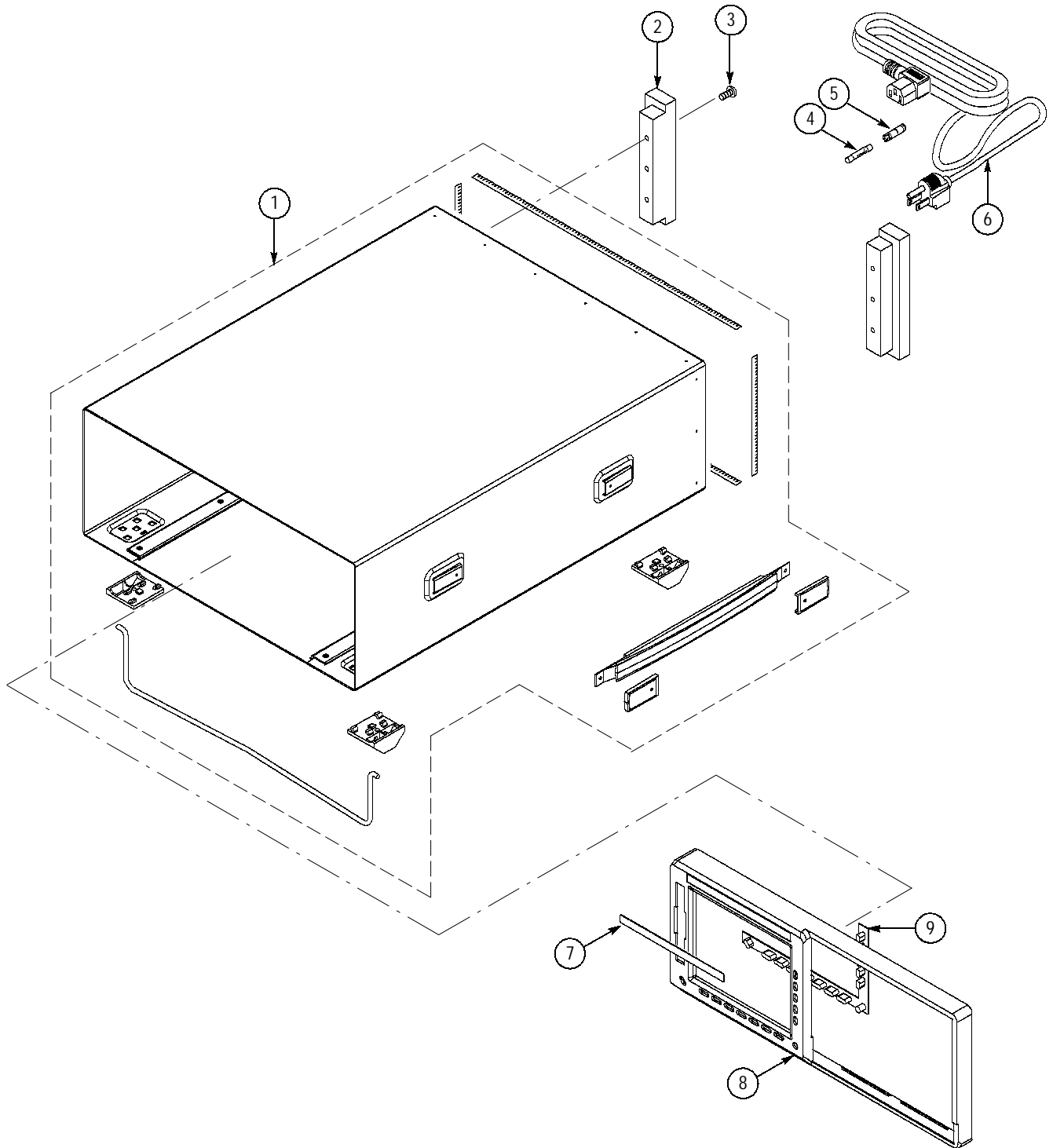

Figure 10-1: Cabinet

Replaceable Mechanical Parts

Replaceable Parts List

Fig. & Index Number	Tektronix Part Number	Serial No. Effective	Serial No. Discont'd	Qty	Name & Description	Mfr. Code	Mfr. Part Number
2-1	366-2114-00			2	KNOB:.925DIA	80009	3662114XX
-2	366-2111-00			3	KNOB:.425DIA	80009	3662111XX
-3	366-2170-00			1	KNOB:1.700DIA	80009	3662170XX
-4	333-4320-00			1	PANEL,FRONT:KEYBOARD,AWG500,POLYCARBONATE	80009	3334320XX
-5	124-0469-00			1	STRIP,TRIM:FRONT PANEL,AL	80009	1240469XX
-6	386-7047-00		J300279	1	SUBPANEL,FRONT:KEYBOARD,AL	80009	3867047XX
	386-7047-01	J300280		1	SUBPANEL,FRONT:KEYBOARD,AL	80009	3867047XX
-7	380-0927-01			1	HOLDER,SWITCH	80009	3800927XX
-8	348-1160-00			2	SHIELD,ELEC:SST,W/CHEVRONS,0.4 PITCH,8.0 L	80009	3481160XX
-9	348-1159-00			2	SHIELD,ELEC:SST,W/CHEVRONS,0.4 PITCH,5.0 L	80009	3481159XX
-10	214-4287-00			1	ACTUATOR:ELASTOMER MAT,FRONT PANEL,RUBBER	80009	2144287XX
-11	377-0579-00			5	INSERT,KNOB:PLASTIC	80009	3770579XX
-12	671-4325-XX			1	CIRCUIT BOARD:A20,FRONT PANEL	80009	6714325XX
-13	211-0946-00			6	SCREW,ASSEM WSHR:M3 X 10MM,PNH,STL ZN PL, W/FLAT & LOCK WSHR	80009	ORDER BY DESC
-14	348-1622-00			36 cm	GASKET,SHIELD:FINGER TYPE,BE-CU, 609.6MM LW/ADHESIVE	80009	3481622XX
-15	386-7138-00			1	SUBPANEL,FRONT:BNC,AL	80009	3867138XX
-16	333-4319-01			1	PANEL,FRONT:BNC,AWG610,POLYCARBONATE	80009	3334319XX

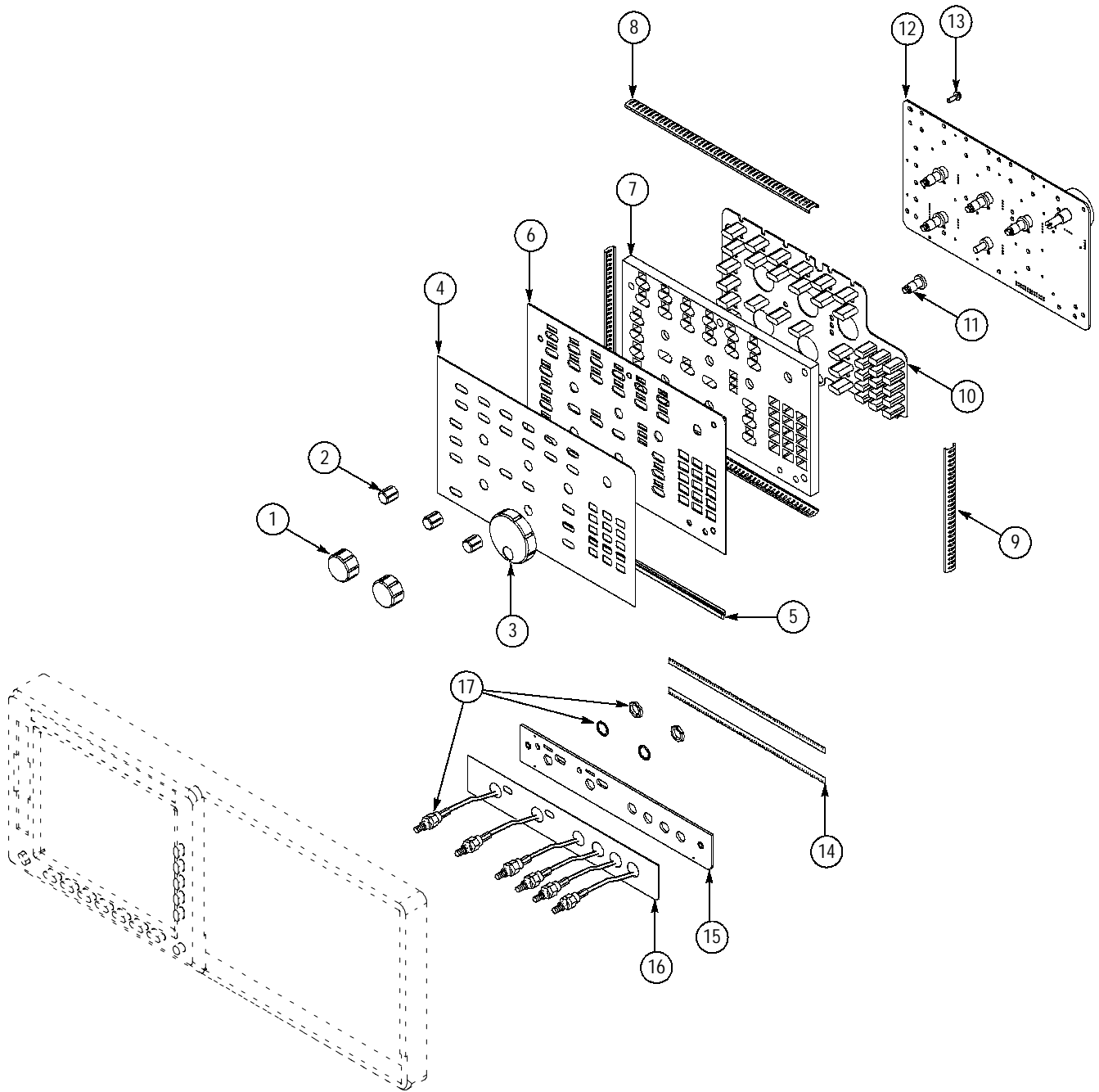

Figure 10-2: Front panel

Replaceable Mechanical Parts

Replaceable Parts List

Fig. & Index Number	Tektronix Part Number	Serial No. Effective	Serial No. Discont'd	Qty	Name & Description	Mfr. Code	Mfr. Part Number
3-1	671-4824-XX			1	CIRCUIT BOARD:A11,CONNECTOR	80009	6714824XX
	671-4966-XX			1	CIRCUIT BOARD:A11,CONNECTOR (OPTION 1 ONLY)	80009	6714966XX
-2	212-0216-00			5	SCREW,MACHINE:M4X8MM L,PNH,STL,MFZN-C, CROSS REC, W/FLAT & LOCK WASHER	80009	ORDER BY DESC
-3	211-0945-00			1	SCREW,MACHINE:M4X8MM L,PNH,STL,MFZN-C, CROSS REC	80009	ORDER BY DESC
-4	210-0008-00			1	WSHR,LOCK:#8 INTL,0.02 THK,STL CD PL	80009	210008XX
-5	620-0067-XX			-	POWER SUPPLY	80009	6200067XX
-6	211-0945-00			4	SCREW,MACHINE:M4X8MM L,PNH,STL,MFZN-C, CROSS REC	80009	ORDER BY DESC
-7	212-0216-00			4	SCREW,MACHINE:M4X8MM L,PNH,STL,MFZN-C, CROSS REC, W/FLAT & LOCK WASHER	80009	ORDER BY DESC

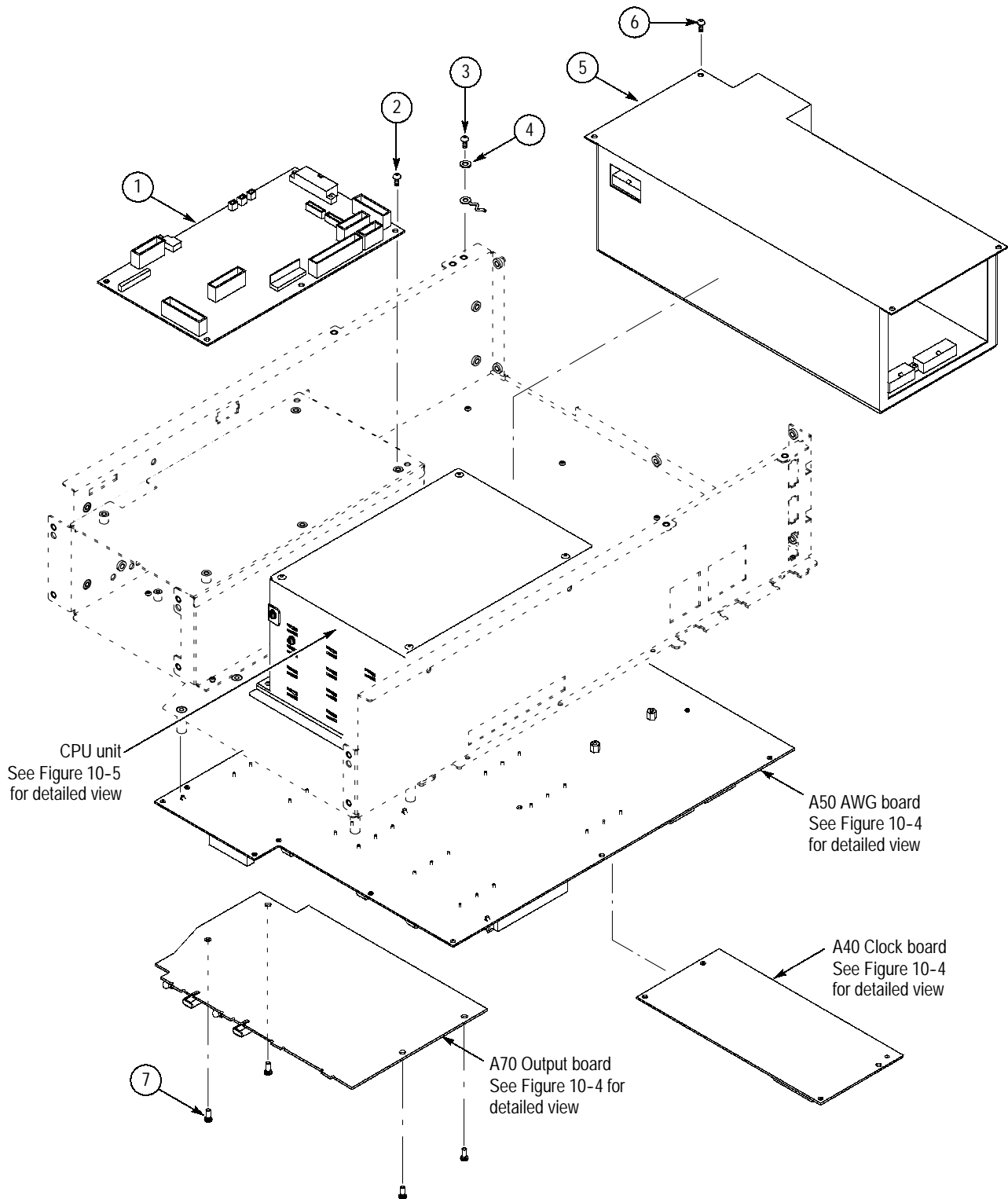

Figure 10-3: Outer chassis modules

Replaceable Mechanical Parts

Replaceable Parts List

Fig. & Index Number	Tektronix Part Number	Serial No. Effective	Serial No. Discont'd	Qty	Name & Description	Mfr. Code	Mfr. Part Number
4-1	671-4829-XX			1	CIRCUIT BOARD:A70,OUTPUT	80080	6714829XX
-2	211-0945-00			4	SCREW,MACHINE:M4X8MM L,PNH,STL,MFZN-C, CROSS REC	80009	ORDER BY DESC
-3	366-0793-01			2	PUSH BUTTON:TEK TAN	80009	3660793XX
-4	343-1613-00			20	RETAINER,CKT BD:A60 MEMORY,SST	80009	3431613XX
-5	671-4828-XX			10	CIRCUIT BOARD:A60,MEMORY	80009	6714828XX
-6	212-0216-00			12	SCREW,MACHINE:M4X8MM L,PNH,STL,MFZN-C, CROSS REC	80009	ORDER BY DESC
-7	211-0945-00			6	SCREW,MACHINE:M4X8MM L,PNH,STL,MFZN-C, CROSS REC	80009	ORDER BY DESC
-8	671-4826-XX			1	CIRCUIT BOARD:A40,CLOCK	80009	6714826XX
-9	129-1517-00			6	SPACER,POST:10 MM L,M4 INT/EXT THD,BRS NI PL,7MM HEX	80009	ORDER BY DESC
-10	671-4827-XX			1	CIRCUIT BOARD:A50,AWG	80009	6714827XX

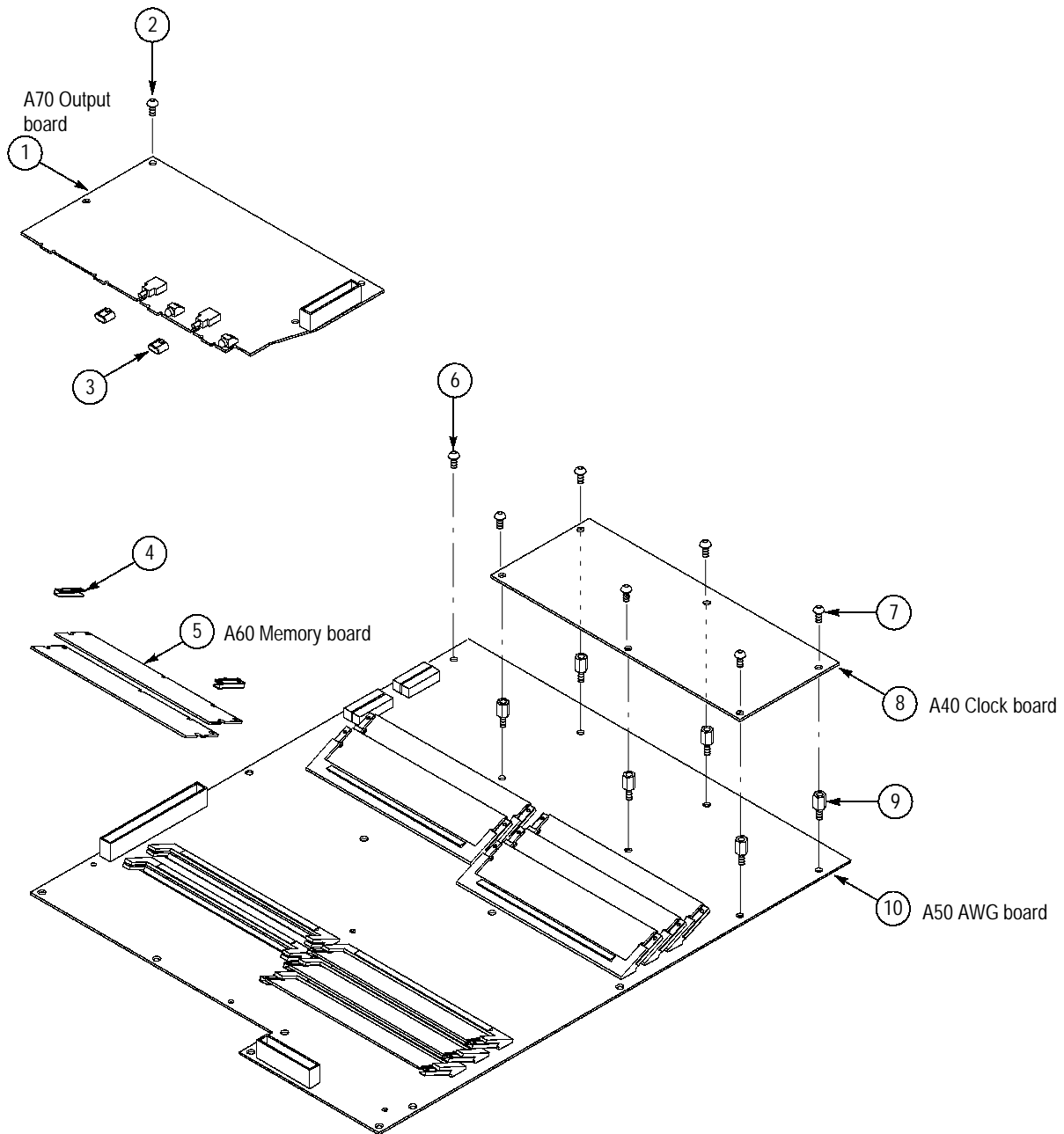

Figure 10-4: Circuit boards

Replaceable Mechanical Parts

Replaceable Parts List

Fig. & Index Number	Tektronix Part Number	Serial No. Effective	Serial No. Discont'd	Qty	Name & Description	Mfr. Code	Mfr. Part Number
5-1	119-5774-XX			1	BOARD,ASSY:BACKPLANE	80009	1195774XX
-2	211-0946-00			4	SCREW,ASSEM WSHR:M3 X 10MM,PNH,STL ZN PL, W/FLAT & LOCK WSHR	80009	ORDER BY DESC
-3	211-0946-00			2	SCREW,ASSEM WSHR:M3 X 10MM,PNH,STL ZN PL, W/FLAT & LOCK WSHR	80009	ORDER BY DESC
-4	343-1651-00			1	RETAINER,CKT BD:CPU,AL	80009	3431651XX
-5	211-0946-00			1	SCREW,ASSEM WSHR:M3 X 10MM,PNH,STL ZN PL, W/FLAT & LOCK WSHR	80009	ORDER BY DESC
-6	119-6074-XX			1	BOARD,ASSY:CPU ¹	80009	1196074XX
-7	119-6197-XX			1	BOARD,ASSY:LAN ¹	80009	1195776XX
-8	671-4825-XX			1	CIRCUIT BOARD:A30,GPIB	80009	6714825XX
	671-4965-XX			1	CIRCUIT BOARD:A30,GPIB (OPTION 10 ONLY)	80009	6714965XX
-9	211-0946-00			4	SCREW,ASSEM WSHR:M3 X 10MM,PNH,STL ZN PL, W/FLAT & LOCK WSHR	80009	ORDER BY DESC
-10	211-0871-00			3	SCREW,ASSEM WSHR:M3 X 6MM L,STL,ZN PL, W/FLAT & LOCK WSHR	80009	ORDER BY DESC
-11	211-0871-00			4	SCREW,ASSEM WSHR:M3 X 6MM L,STL,ZN PL, W/FLAT & LOCK WSHR	80009	ORDER BY DESC
-12	119-6134-XX			1	HARD DISK ¹	80009	1196134XX
	119-6135-XX			1	SOLID STATE DRIVE ¹ (for Option 10)	80009	1196135XX
-13	119-6133-XX			1	FLASH DISK ¹	80009	1196133XX
-14	211-0946-00			2	SCREW,ASSEM WSHR:M3 X 10MM,PNH,STL ZN PL, W/FLAT & LOCK WSHR	80009	ORDER BY DESC

1 These modules are calibrated and initialized before shipment.

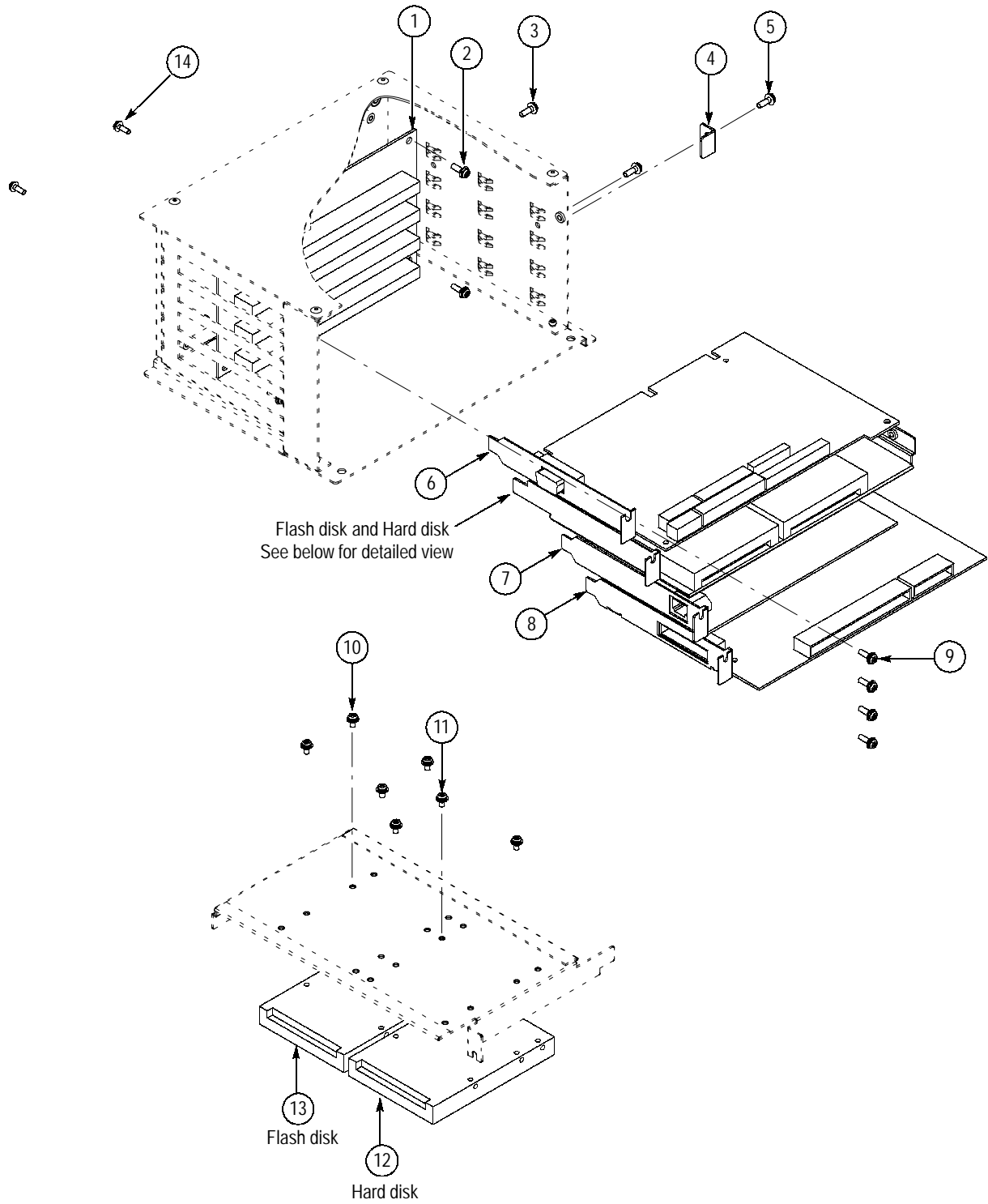

Figure 10-5: CPU unit

Replaceable Mechanical Parts

Replaceable Parts List

Fig. & Index Number	Tektronix Part Number	Serial No. Effective	Serial No. Discont'd	Qty	Name & Description	Mfr. Code	Mfr. Part Number
6-1	211-0946-00			1	SCREW,ASSEM WSHR:M3 X 10MM,PNH,STL ZN PL, W/FLAT & LOCK WSHR	80009	ORDER BY DESC
-2	407-4554-00			1	BRACKET,CONN:MODULAR CONN	80009	4074554XX
-3	174-3880-01			1	CABLE,ASSY:W10,LAN	80009	1743880XX
-4	220-0194-00			1	NUT,PLATE:STL	80009	ORDER BY DESC
-5	174-3881-00			1	CABLE,ASSY:W170,GPIB	80009	1743881XX
-6	671-4326-XX			1	CIRCUIT BOARD:A90,KEYBOARD	80009	6714326XX
-7	129-1493-01			2	SPACER,POST:5MM L,M3.5 INT/M3 EXT,STL,BLK ZN PL, 7MM HEX	80009	1291493XX
-8	174-3879-00			1	CABLE,ASSY:W127,DISPLAY MONITOR OUT	80009	1743879XX
-9	129-1051-00			4	SPACER,POST:4.8MM L,4-40INT/4-40EXT, STL 4.8MM HEX W/WSHR	80009	1291051XX
-10	174-3878-00			1	CABLE,ASSY:W520,EVENT OUT	80009	1743878XX
-11	131-1315-01			4	CONN,RF,JACK:BNC,50OHM,FEMALE,STR,PEL TORA, PANEL MOUNT	80009	1311315XX
-12	211-0945-00			6	SCREW,MACHINE:M4X8MM L,PNH,STL,MFZN-C, CROSS REC	80009	ORDER BY DESC
-13	386-7000-01			1	SUBPANEL,FRONT(FINISHED)	80009	3867000XX
-14	348-1569-00			114 cm	SHLD GASKET,ELEC:MESH TYPE,3.2MM OD, SI SPONGE CORE	80009	3481569XX
-15	344-0472-00			6	BUSHING:BUSHING,NYLON,GRAY	80009	3440472XX
-16	343-0549-00			3	STRAP,TIEDOWN:1.6-19MM DIA,66NYLON	80009	3430549XX
-17	220-0193-00			2	NUT,PLAIN,HEX:M4X7MM HEX,STL,ZN-C	80009	ORDER BY DESC
-18	333-4231-00			1	PANEL,REAR,AWG600,AL	80009	3334231XX

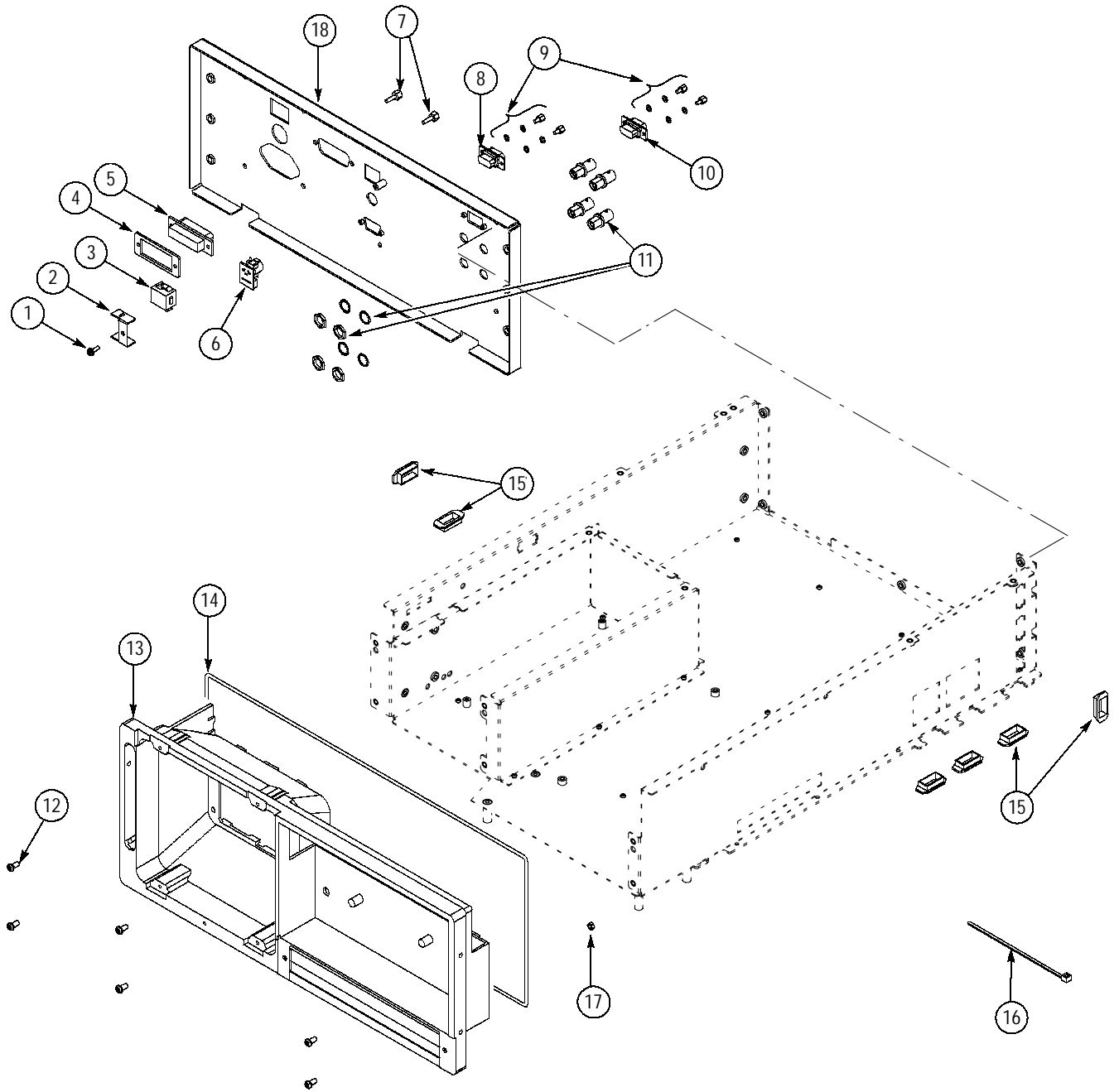

Figure 10-6: Chassis

Replaceable Mechanical Parts

Replaceable Parts List

Fig. & Index Number	Tektronix Part Number	Serial No. Effective	Serial No. Discont'd	Qty	Name & Description	Mfr. Code	Mfr. Part Number
7-1	119-5953-00			1	FLOPPY DISK DRIVE:	80009	1195953XX
-2	105-1081-00			1	BRACKET,,SPACER	80009	1051081XX
-3	211-1033-00			1	SCREW,MACHINE:M2.6X3MM L,PNH,BRS,NI PL,CROSS REC	80009	ORDER BY DESC
-4	441-2224-00	J300280		1	CHASSIS,FDD:STL,SHIELD	80009	ORDER BY DESC
-5		J300280		1	CHASSIS,FDD:STL,BRACKET ,ATTACHING PART OF 4	80009	ORDER BY DESC
-6	211-0823-00			1	SCREW, MACHINE: M2.6 X 5MM L, BDGH, STL, MFZN-C, CROSS REC	80009	ORDER BY DESC
-7	211-1034-00			1	SCREW, MACHINE: M2.6 X 10MM L, PNH, STL, MFZN-C, CROSS REC	80009	ORDER BY DESC
-8	211-0945-00		J300279	2	SCREW,MACHINE:M4X8MM L, PNH, STL, MFZN-C, CROSS REC	80009	ORDER BY DESC
	212-0216-00	J300280		2	SCREW,MACHINE:M4X8MM L, PNH, STL, MFZN-C, CROSS REC,W/FLAT & LOCK WASHER	80009	ORDER BY DESC
-9	211-0948-00			12	SCREW,MACHINE:M4X45MML, PNH, STL, MFZN-C, CROSS REC W/FLAT & LOCK WSHR	80009	ORDER BY DESC
-10	119-5777-00			3	FAN,TUBEAXIAL:12V ,0.6A,7.2W ,2520RPM,3.04MMM	80009	1195777XX
-11	343-0549-00			4	STRAP,TIEDOWN:1.6-19MM DIA,66NYLON	80009	3430549XX

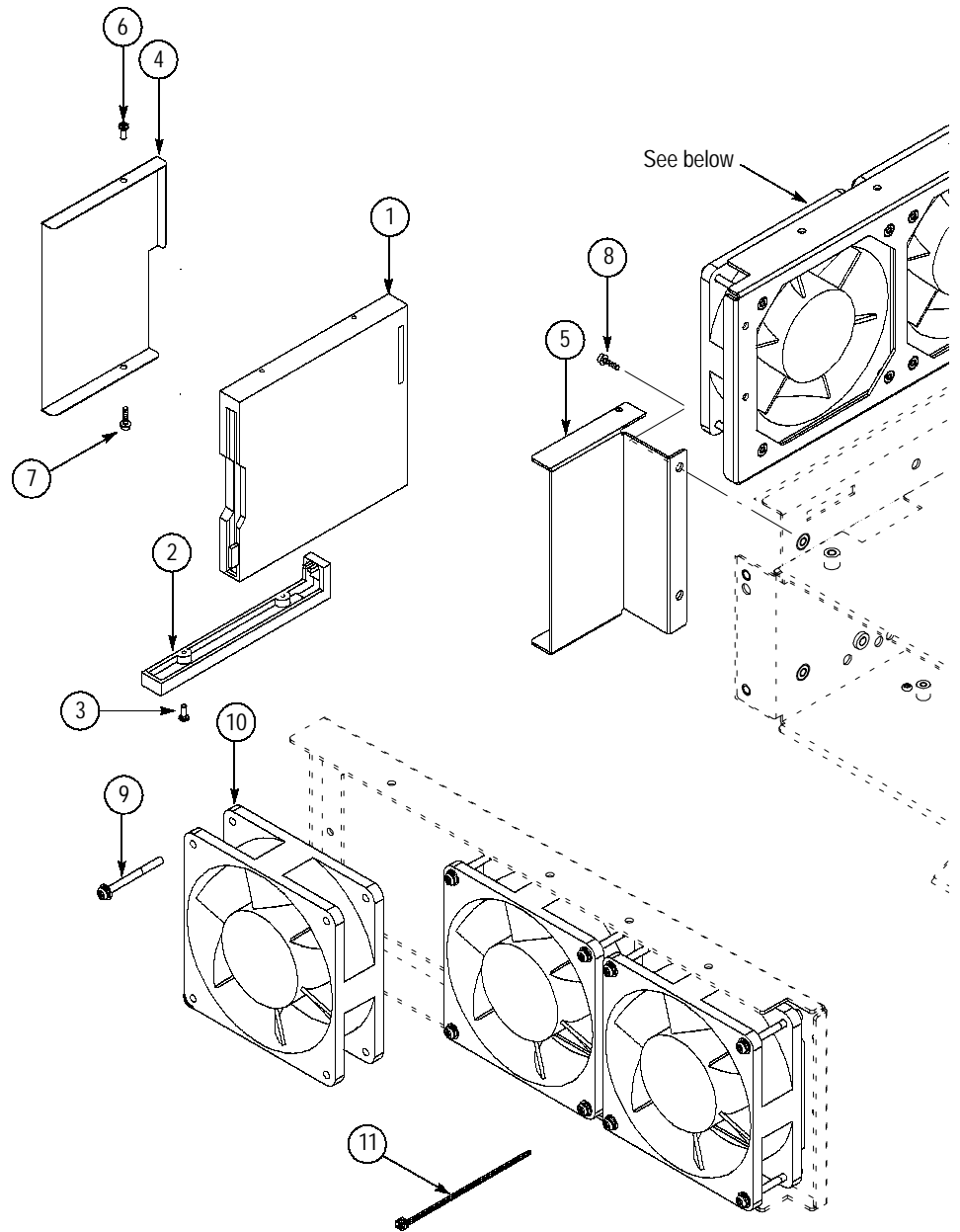

Figure 10-7: Floppy disk and Fan

Replaceable Mechanical Parts

Replaceable Parts List

Fig. & Index Number	Tektronix Part Number	Serial No. Effective	Serial No. Discont'd	Qty	Name & Description	Mfr. Code	Mfr. Part Number
8-1	211-0945-00			3	SCREW,MACHINE:M4X8MM L,PNH,STL,MFZN-C, CROSS REC	80009	ORDER BY DESC
-2	259-0070-00			1	FLEX CIRCUIT:	80009	2590070XX
-3	426-2576-00		J300279	1	FRAME,DISPLAY:MAIN FILTER,AL	80009	4262576XX
	426-2576-01	J300280		1	FRAME,DISPLAY:MAIN FILTER,AL	80009	4262576XX
-4	378-0448-00			1	FILTER,LIGHT:ACRILIC	80009	3780448XX
-5	386-6211-02			1	RETAINER,FILTER:DUST SEAL ASSY,LEXAN	80009	386621102
-6	211-0945-00			2	SCREW,MACHINE:M4X8MM L,PNH,STL,MFZN-C, CROSS REC	80009	ORDER BY DESC
-7	119-5922-00			1	CRT	80009	1195922XX
-8	211-0946-00			6	SCREW,ASSEM WSHR:M3 X 10MM,PNH,STL ZN PL, W/FLAT & LOCK WSHR	80009	ORDER BY DESC
-9	211-0945-00			2	SCREW,MACHINE:M4X8MM L,PNH,STL,MFZN-C, CROSS REC	80009	ORDER BY DESC

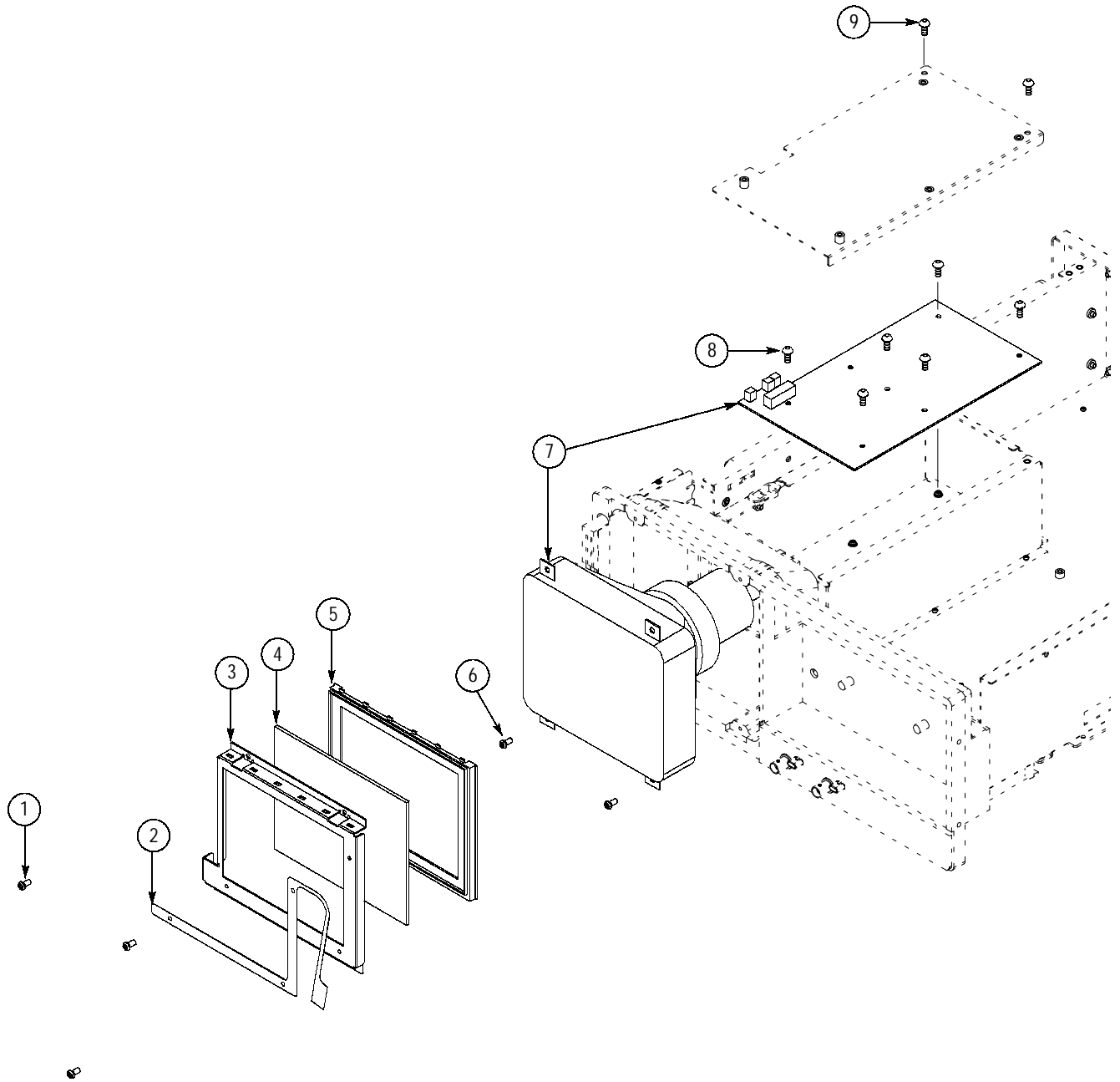

Figure 10-8: Display

Replaceable Mechanical Parts

Replaceable Parts List

Fig. & Index Number	Tektronix Part Number	Serial No. Effective	Serial No. Discont'd	Qty	Name & Description	Mfr. Code	Mfr. Part Number
9-1	351-0623-00			1	SLIDE,DWR,EXT:22.0 X 1.54,STEELSAFETY CONTROLLED	80009	3510623XX
-2	212-0507-00			4	SCREW,MACHINE:10-32 X 0.375,PNH,STL CD PL,POZ	80009	ORDER BY DESC
-3	351-0313-00			1	GUIDE,RACKMOUNT:19.218 L,PAIR	80009	3510313XX
-4	407-4555-00			2	BRACKET,SUPPORT:SIDE,RACKMOUNT,AL	80009	4074555XX
-5	211-0949-00			6	SCREW,MACHINE:M5X12MM L,PNH,STL ZN PL, CROSS REC W/FLAT & LOCK WSHR	80009	ORDER BY DESC
-6	212-0509-00			4	SCREW,MACHINE:10-32 X 0.625,PNH,STL CD PL,POZ	80009	ORDER BY DESC
-7	210-1003-00			4	WSHR,FLAT:0.2 ID X 0.438 OD X 0.036 BRS NP	80009	ORDER BY DESC
-8	210-0142-00			4	WSHR,PLAIN:5.5MM ID X 12MM OD,TEFLON	80009	ORDER BY DESC
-9	211-0945-00			4	SCREW,MACHINE:M4X12MM L,PNH,STL,MFZN-C, CROSS REC	80009	ORDER BY DESC
-10	407-4020-00			2	BRACKET,SUPPORT:FRONT,ALUMINUM	80009	4074020XX
-11	212-0507-00			4	SCREW,MACHINE:10-32 X 0.375,PNH,STL CD PL,POZ	80009	ORDER BY DESC
-12	367-0022-00			2	HANDLE,BOW:4.579 L,BRS CRPL	80009	3670022XX
-13	101-0142-01			1	TRIM,DECORATIVE:FRONT	80009	101014201

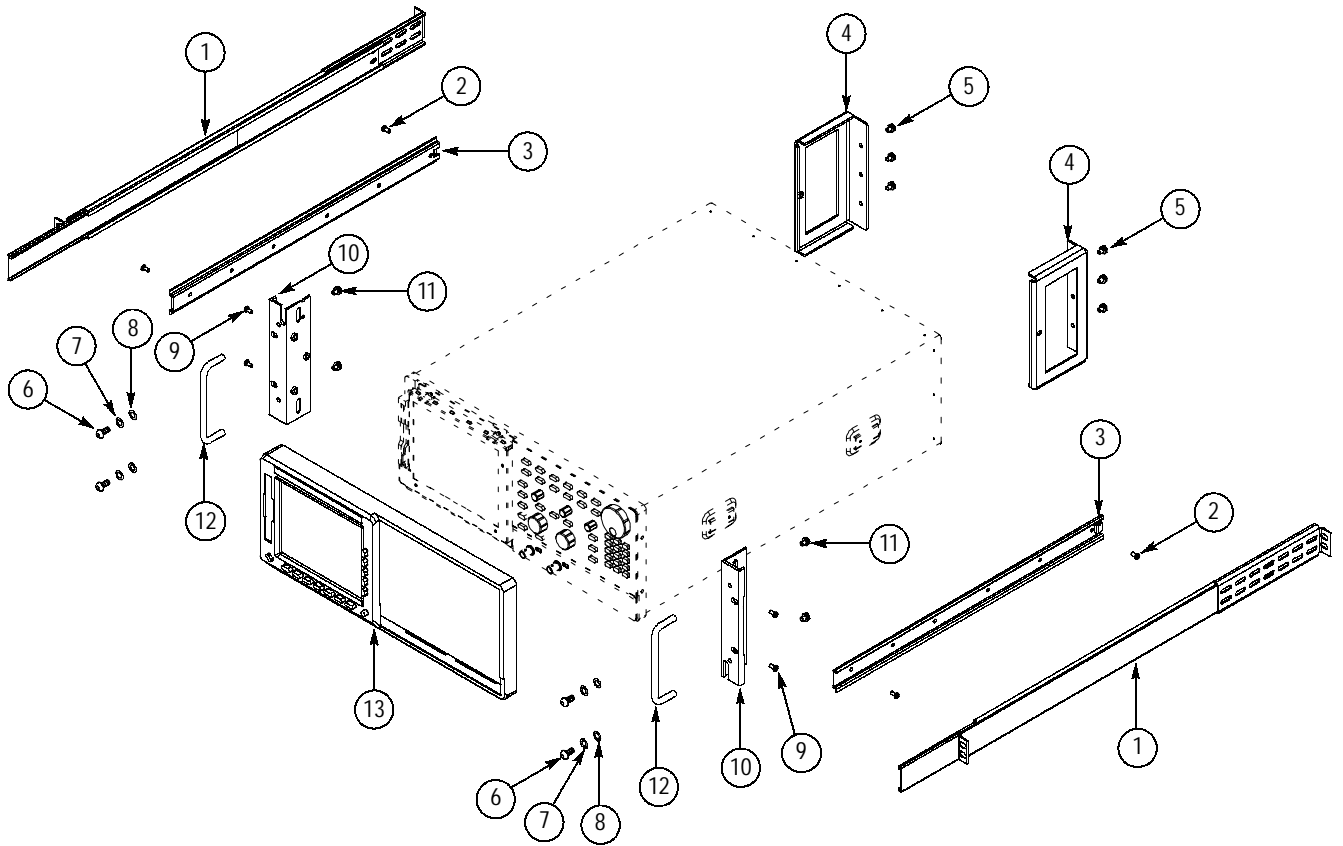

Figure 10-9: Rack mount

Replaceable Mechanical Parts

Replaceable Parts List

Fig. & Index Number	Tektronix Part Number	Serial No. Effective	Serial No. Discont'd	Qty	Name & Description	Mfr. Code	Mfr. Part Number
STANDARD ACCESSORIES							
	015-1022-00			2			0151022XX
	063-3216-XX			1	SOFTWARE PKG:3.5 DISK,AWG610 WAVEFORM LIB		0633216XX
	063-3217-XX			1	SOFTWARE PKG:3.5 DISK,AWG610 SERIES SAMPLE PRGM		0633217XX
	063-3218-XX			1	SOFTWARE PKG:3.5 DISK,AWG610 PERF CHECK/ADJ		0633218XX
	071-0554-XX			1	MANUAL,TECH:USER,AWG610		0710554XX
	071-0555-XX			1	MANUAL,TECH:PROGRAMMER,ENGLISH VERSION,AWG610		0710555XX
	-----			1	CABLE ASSY,PWR:3,18 AWG,92 L,SVT,TAN (SEE FIGURE 10-1-6)		
	161-0104-06			1	CA ASSY,PWR:3,1.0MM SQ,250V/10A,2.5 METER (OPTION A1 - EUROPEAN)	S3109	198-010
	161-0104-07			1	CA ASSY,PWR:3,1.0MM SQ,240V/10A,2.5 METER (OPTION A2 - UNITED KINGDOM)	S3109	209010
	161-0104-05			1	CA ASSY,PWR:3,1.0MM SQ,250V/10A,2.5 METER (OPTION A3 - AUSTRALIAN)	S3109	198-010
	161-0104-08			1	CA ASSY,PWR:3,18 AWG,250/10A,98 INCH L (OPTION A4 - NORTH AMERICAN)	2W733	ORDER BY DESC
	161-0167-00			1	CA ASSY,PWR:3,0.75MM SQ,250V/10A,2.5 METER (OPTION A5 - SWITZERLAND)	S3109	ORDER BY DESC

Replaceable Parts List (Cont.)

Fig. & Index Number	Tektronix Part Number	Serial No. Effective	Serial No. Discont'd	Qty	Name & Description	Mfr. Code	Mfr. Part Number
OPTIONAL ACCESSORIES							
	011-0049-01			1	TERMN, COAXIAL: 50 OHM, 2W, BNC	64537	T132DS
	012-0991-00			1	CABLE, INTCON: SHLD CMPST, GPIB: CRC, 12 TW PR	6D224	81190-020
	012-1256-00			1	CABLE, INTCON: 50 OHM COAX, 98.0 L	80009	0121256XX
	012-1342-00			1	CA ASSY, RF: COAXIA; RFD, 50 OHM, 24 L, BNC, MALE	80009	0121342XX
	012-1565-00			1	CA ASSY, RF: 50 OHM COAX, 150CM L, SMA, MALE-MALE	80009	0121565XX
	015-0554-00			1	SMA-BNC ADAPTER:MALE-FEMALE	80009	0150554XX
	015-0560-00			1	SMA DELAY CABLE, 2 NS, MALE-MALE	80009	0150560XX
	015-0561-00			1	SMA DELAY CABLE, 5 NS, MALE-MALE	80009	0150561XX
	015-0562-00			1	SMA DELAY CABLE, 1 NS, MALE-MALE	80009	0150562XX
	015-0572-00			1	SMA-BNC ADAPTER, FEMALE-MALE	80009	0150572XX
	015-0657-00			1	FILTER, LOW PASS:100MHZ, 50 OHM,BNC,TUBULAR	80009	0150657XX
	015-0658-00			1	FILTER, LOW PASS:200MHZ, 50 OHM,BNC,TUBULAR	80009	0150658XX
	015-0659-00			1	FILTER, LOW PASS:400MHZ, 50 OHM,BNC,TUBULAR	80009	0150659XX
	015-0660-00			1	FILTER, LOW PASS:DC-800MHZ, 50 OHM, 0.5W, BNC	80009	0150660XX
	015-1014-00			1	SMA DIVIDER, 50 OHM, MALE	80009	0151014XX
	015-1016-00			1	SMA T-CONNECTOR, MALE-FEMALE & MALE	80009	0151016XX
	015-1022-00			1	SMA 50 OHM TERMINATOR. MALE	80009	0151022XX
	020-1693-00			1	SMA ADAPTER KIT	80009	0201693XX
	071-0556-XX			1	MANUAL, TECH: SERVICE, AWG500	80009	0710556XX
	174-1341-00			1	SMA CABLE, 50 OHM, 100 CM, MALE-MALE	80009	1741341XX
	174-1427-00			1	SMA CABLE, 50 OHM, 50 CM, MALE-MALE	80009	1741427XX
	174-1428-00			1	SMA CABLE, 50 OHM, 120 CM, MALE-MALE	80009	1741428XX
	200-3696-01			1	COVER, FRONT: PLASTIC	80009	200369601

Replaceable Mechanical Parts

Replaceable Parts List (Cont.)

Fig. & Index Number	Tektronix Part Number	Serial No. Effective	Serial No. Discont'd	Qty	Name & Description	Mfr. Code	Mfr. Part Number
					CBLE LIST		
W310	012-1561-00			1	CA ASSY, SP, ELEC: 50 OHM COAX, 50 CM L, 9-1, SMA-PELTRA, SST SHELL	80009	0121561XX
W311					CA ASSY, SP, ELEC: 50 OHM COAX, 50 CM L, 9-2, SMA-PELTRA, SST SHELL		
W320					CA ASSY, SP, ELEC: 50 OHM COAX, 50 CM L, 9-3, SMA-PELTRA, SST SHELL		
W321					CA ASSY, SP, ELEC: 50 OHM COAX, 50 CM L, 9-4, SMA-PELTRA, SST SHELL		
W701					CA ASSY, RF, ELEC: 50 OHM COAX, 15 CM L, 9-1, SMA TO PELTRA, SST SHELL		
W702					CA ASSY, RF, ELEC: 50 OHM COAX, 15 CM L, 9-2, SMA TO PELTRA, SST SHELL		
W710	012-1562-00			1	CA ASSY, RF, ELEC: 50 OHM COAX, 35 CM L, 9-1, W/PELTRA BOTH ENDS	80009	0121562XX
W720					CA ASSY, RF, ELEC: 50 OHM COAX, 35 CM L, 9-2, W/PELTRA S/T/S/T		
W410					CA ASSY, RF, ELEC: 50 OHM COAX, 25 CM L, 9-1, W/PELTRA		
W500	012-1563-00			1	CA ASSY, SP, ELEC: 50 OHM COAX, 45 CM L, 9-4, PELTRA	80009	0121563XX
W330					CA ASSY, SP, ELEC: 50 OHM COAX, 45 CM L, 9-1, W/PELTRA		
W200					CA ASSY, SP, ELEC: 50 OHM COAX, 35 CM L, 9-2, W/PELTRA S/T/S/T		
W350					CA ASSY, SP, ELEC: 50 OHM COAX, 50 CM L, 9-3, W/PELTRA		

